

DESIGNING AND ANALYZING AIRFLOW IN A HYBRID RACING CAR USING CFD ANALYSIS

¹TALLOORI SAI KUMAR, ²BHUKYA SURESH, ³YANAKAPATI KRISHNA, ⁴M. VANI

^{1,2,3}Assistant Professor, ⁴Student

Department Of Mechanical Engineering

Abdul Kalam Institute of Technological Sciences, Kothagudem, Telangana

ABSTRACT:

Many conventional automotive conveniences are also included with hybrid electric vehicles. The drive system is powered by a gas or electric motor and an internal combustion engine. The issue of waste emissions from internal combustion engines still exists, and the design and control system of hybrid electric vehicles pose challenges. We also opened and closed a variety of outlets and cooling air ducts to see how the design parameters would change. The first study claims that airflow through the wheelhouses increases drag. In the second trial, input ducts allowed the researchers to regulate the airflow from the grilles into the cooling system. An autonomous thermal velocity-powered land platform was the subject of a feasibility study. Component selection and sizing was done with the required driving characteristics in mind. For this project, NX 12.0 and other software were employed during the design phase. Ansys Workbench software's Explicit Dynamic module will be used to conduct crash analysis on a variety of materials, including carbon steel and aluminum 2024 for the vehicle body and Using the CFD, a velocity of 120 km/h (-33340 mm/sec) was attained with the use of compressed air, a novel operating mode, and component reselection.

Keywords: drive system, hybrid drive, ANSYS, CFD, NX 12.0

1.0 INTRODUCTION

Hybrid cars are becoming more popular and more common. Basically, a hybrid car is one that uses two or more engines i.e. an electric motor and a conventional engine (either petrol or diesel). The electric engine powers the car at lower speeds and gas engine powers it at higher speeds. A hybrid car like Toyota Prius and Civic Hybrid not only conserves fuel but also produce less CO₂ emissions. Though hybrid vehicles are now growing in popularity but still few people are actually using it mainly due to lack of knowledge of how hybrid vehicles work and whether they're as good as other gasoline powered vehicles.

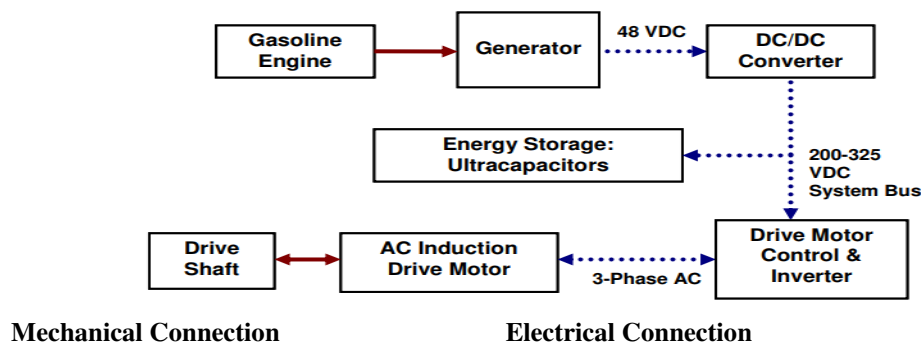

Figure 1: Block Diagram of our Series Hybrid System

While the technology has existed since the early 1900's, it has only been in the past decade or so that the price of manufacturing them has brought them into the range of possibility for the average driver. There are also more government incentive programs that use credits and special discounts to support the purchase and use of hybrid vehicles. Many cities are switching their public transportation and service vehicles over to hybrid cars and buses as a part of the program to become more environmentally

CLASSIFICATION OF HYBRID DRIVES ACC. TO ENGINE COUPLING:

In addition to the functional aspects, the coupling of the internal combustion engine and the electric machine or machines is another criterion to classify the hybrid vehicles. In the following, relevant variants are presented and

explained by In the in-line hybrids, the components are arranged along the same axis. As shown in the internal combustion engine is permanently coupled to a generator which produces electrical energy. It is used either directly by the e-motor to drive the vehicle, or stored in an accumulator. Besides batteries, capacitors with high power density the so-called “super caps” (super capacitors) may be used as energy storage system.



Figure 2:In-line hybrid drive

However, this optimization of the combustion engine operation has the drawback of multiple energy conversion. The mechanical energy of the combustion engine is first converted by the generator in electrical energy, and then stored in the battery if not immediately needed. Finally, it is converted back into mechanical energy in the driving e-motor. The associated energy losses can be compensated only by the optimized operation of the IC engine, if the driving profile is quite dynamic and accelerations and decelerations predominate, as for example in the case of city buses. Especially for low-floor buses, the installation of individual drives either near or inside the wheels (hub e-motors) may be beneficial. The direct mechanical coupling of the engine and the wheels is omitted offering thus a clear packaging advantage.

Further, the power transmission to more than one axle can be realized in a relatively simple way. It

Objectives:

- To study the performance parameters of Hybrid Driving vehicle, the driving motor system
- To design the Racing car was done by using NX 8.0
- To Design model is Analysed by using CFD with compressed Air

2.0 LITARATURE REVIEW

Anjul Chauhan, et al [1] The first hybrids on the market, which were designed to achieve high efficiency by streamlining and minimizing as much as possible. The Insight used the pioneering Integrated Motor Assist (IMA) technology, which boosts torque at low RPMs where the engine is less powerful. This hybrid system is a modified parallel system with the motor and the engine connected directly. D. Raghunandan, A. Pandiyan [2] Parallel and series configurations of hybrid cars that will be technically possible in the next decade are defined and analyzed with the use of a malleable Advanced Vehicle Simulator (ADVISOR). There is a comparison made between the fuel economy of two diesel-powered hybrid vehicles and that of a diesel-powered internal combustion engine vehicle using the same technology. Shithin PV et al [3] integrated starter/generator (ISG) hybrid electric vehicle (HEV) powertrain dynamic simulation model in Simulink models of the hybrid electric scooter's individual components are developed in Matlab/Simulink. By means of this model, we examine the efficiency of the suggested hybrid powertrain in four different conditions. The simulation results validate the practical capabilities of the proposed hybrid system. Sathish Kumar And Vignesh [4] An engine, motor/alternator, continuously variable transmission (CVT) device, powertrain control module (PCM), and three-helical gear set are the main components of the unique parallel-type hybrid electric power system proposed here. The engine's thermal efficiency and pollution levels are both optimized by the servomotors that control its output to the final power-output axle and the alternator. Perez, L.; Pilotta[5] included a hybrid drivetrain with variable speed and torque coupling. With this powertrain, the engine

speed is disconnected from the wheel speed using a planetary gear unit and a generator/motor. Engine torque is isolated from wheel torque via a second gear unit and traction motor mounted on a shaft. Viehmann, A.; Rinderknecht [6] Gasoline engines and electric motors work together in hybrid power systems, with the power being conveyed via a CVT, a rubber V-belt, and chain drives. The system's four modes electric-motor mode, engine mode, engine/charging mode, and power mode work together to maximize efficiency and reduce pollution. Travis, E.; Torrey [7] introduced an innovative method for addressing the issue of power control strategy in a series hybrid electric car. They established a cost structure and three distinct operational modes. They developed a classifier based on a support vector machine to help decide which mode of operation to employ throughout driving cycles (SVM Jing, L.; Xin-ran, W.; Lin-hui [8] investigated the hybrid electric vehicle's energy management plan. They summed up three different energy management strategies and compared the repercussions of choosing one strategy over another in light of the intensity and duration of the duty cycle over which the vehicle is expected to operate. Zainab, A.; El, A.; Daniela [9] provided a method for building electric and hybrid vehicle propulsion systems based on the dynamics of the vehicle. This technique seeks to identify the electric powertrain's ideal torque-speed profile. Long-term continuous power operation benefits both the getting-moving and cruising phases, as confirmed by the study's authors. Wu, G.; Zhang, X.; Dong [10] resulted in an assessment of the energy and power needed for moving an automobile. A variety of commercial line options for electric and hybrid automobiles in urban areas are surveyed. When considering urban driving cycles, average and peak power demands differ significantly, making comparisons difficult for energy assessments.

3.0 METHODOLOGY

The adopted approach is based on the comparison in terms of performances, consumptions and weights between two configurations of the same aircraft equipped with two different propulsion systems: a traditional diesel engine versus a parallel hybrid diesel-electric propulsion system. The parallel hybrid diesel-electric propulsion systems consist in a diesel internal combustion engine, an electric motor, a rechargeable battery pack and a propeller.

FORMULATION OF DESIGN REQUIREMENTS

The primary goal was to calculate the amount of drag experienced by the hybrid electric vehicle's body (HEV). Pressure points at various locations on the vehicle were used for the analysis, and speeds between 40 and 110 km/h were considered. In order to analyze the car's body, we used a CAD model that took into account the discretization of the mass and momentum equations. Based on the analysis of the need to put into military service logistic and engineering platforms, initial requirements for the platform were formulated. The requirements and objectives with regard to the drive system for the medium-sized unmanned land platform under design are as follows:

- total weight of vehicle – 800 kg,
- travelling speed - 20 km/h,
- instantaneous travelling speed - 40 and 110 km/h,
- travel at 5 km/h for 8 h,
- silent mode travel possible in any terrain type,
- negotiating narrow passages - 1.2 to 1.5 m,
- turning radius - 4 m,

Capability of turning in place,

Negotiating rubble heaps, high curbs, stairs, marsh and desert areas,

The drive unit must meet the requirements specified above and in addition it must have appropriate performance specifications among the available solutions. In order to determine the optimum drive system to be used in the unmanned land platform, multi-criteria analysis was applied evaluating every possible drive option. The drive systems selected, are those that are in general use in similar designs and meet most of the specified requirements.

MOTOR DESIGN

In this section, an induction motor design is considered. In a 53-bar rotor was considered together with a 40-bar adjustment to aid time-stepped FEA (allowing 5-bar periodicity rather than whole motor simulation). The first-pass design was designed using the analytical simulations in *SPEEDPC-IMD*, but to allow for more accuracy in calculation, only time-stepped (or transient) FEA is reported here so that the 40-bar design is focused upon. The

eight-pole arrangements maintained—further work would be to compare other pole number IMs to the eight-pole arrangements used here.

- **Simulation environment and geometry foundation** improvements reduce the time spent working with geometry and accelerate analysis modeling.
- **Multi-discipline simulation and optimization** enhancements broaden NX CAE to include new topology optimization and multi-physics analysis solutions.
- **Systems-level simulation** improvements streamline finite element assembly management and expand high performance computing capacity for computational fluid dynamics (CFD) analysis.
- **High-Definition 3D (HD3D) capabilities** include enhancements like new simulation “results measures”, that allow users to tie results directly to requirements so teams can make smarter decisions

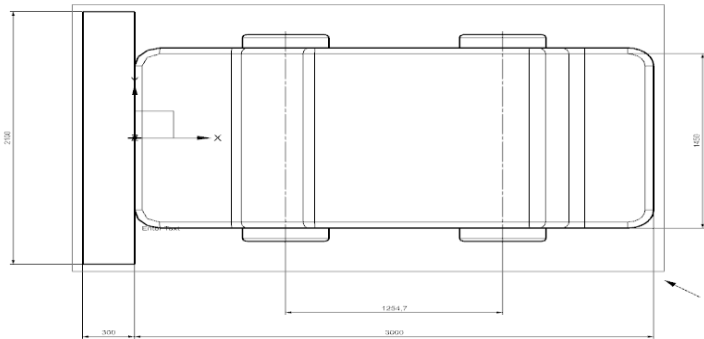

Figure 5: modeling view of racing car in NX8.0

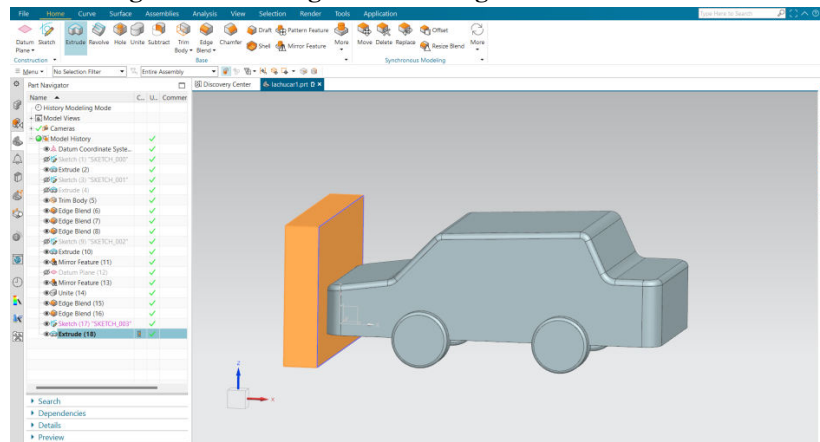

Figure 6: model view of racing car system

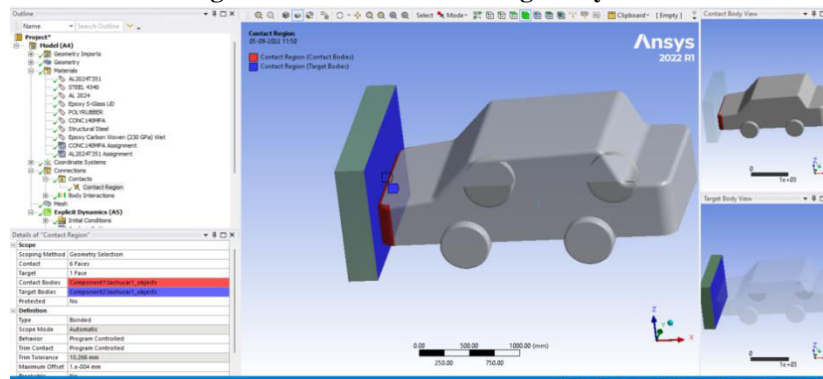

Figure 7: Contact region

The real benefit is that the links remain associative. As a result, any changes made to this external data are notified and the model can be updated quickly. NX 12.0 the basic tasks by providing different workbenches. A workbench is defined as a specific environment consisting of a set of tools which allows the user to perform specific design tasks in a particular area.

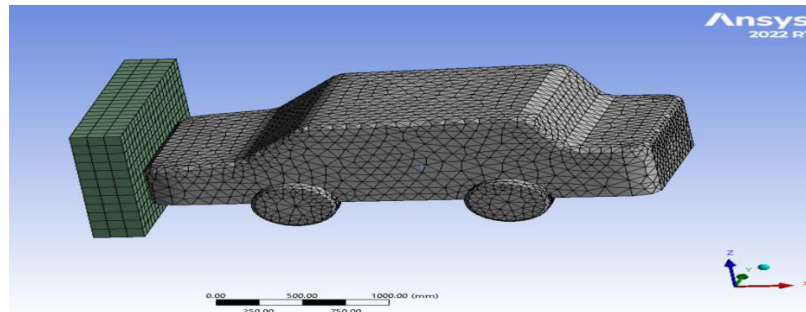

Figure 8: Meshed model

Meshing involves dividing the entire model into small pieces (elements). The element type is decided first to mesh the model. A coarse mesh was generated with 10331 nodes and 9649 elements. Velocity was added in the Initial Conditions of Explicit Dynamics. To justify the suggestion of a material, three different velocities of -33340 m/s were taken along the negative X-direction such that the car would collide with the wall with these velocity



Figure 9: Hybrid drive system racing car

The Figure shown is the meshed model of rigid flange coupling in the ANSYS analysis for the static structural process. To analyses, the FEM triangular type of mesh is used for the rigid flange coupling in the ANSYS environment.

4.0 RESULTS AND DISCUSSIONS:

The crashworthiness of a car determines its structural integrity. The increasing importance of the safety of a passenger car has become a relevant field of study in terms of passenger safety, frame analysis, and material selection. With the advent of Material Sciences and Composites, selecting an appropriate material has become difficult. Composites offer higher structural strength without increasing weight. The possibilities in terms of use in the automobile industry thus widen and open a broader scope of the analysis.

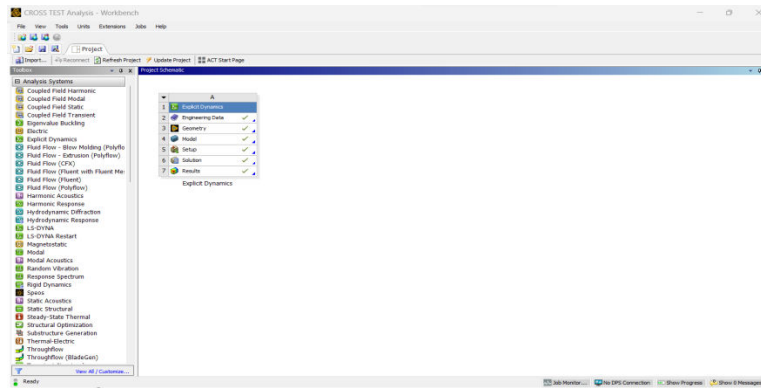

Figure 10: ANSYS Layout

Explicit Dynamic Analysis:

Explicit uses explicit time integration to solve the equations of motion. It solves short-duration problems with complex material response yet makes it easy to set up a problem with minimum input and effort. ANSYS Explicit Dynamics was used for this study. The Engineering Data was updated. Concrete (non-linear) was chosen as additional material. Al2024, Poly rubber, and Carbon steel was added to the material library, and the following properties for the same were input for each material: Density, Isotropic Elasticity (Young's Modulus and Poisson's Ratio), Bilinear Isotropic Hardening (Yield Strength and Tangent Modulus), and Specific Heat.

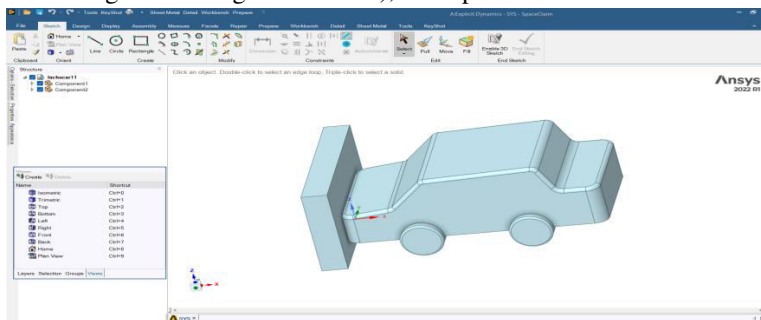

Figure 11: Geometry creation in SpaClaim

The geometry was imported into ANSYS and the Model was opened. Geometry settings were updated. Concrete material was assigned to the wall, and the stiffness behaviour was changed from the default 'flexible' to 'rigid'. Different materials were assigned to the car, and a thickness of 10 mm was given to the car body.

Explicit Dynamic Analysis of hybrid car using AL2024 Material

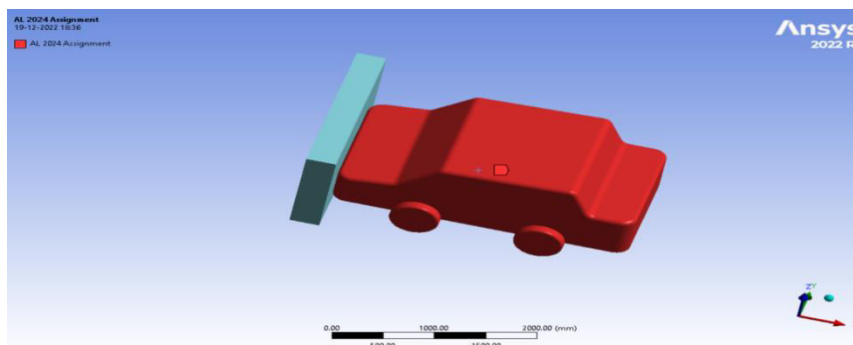

Figure 12: Al2024 Material Assignment

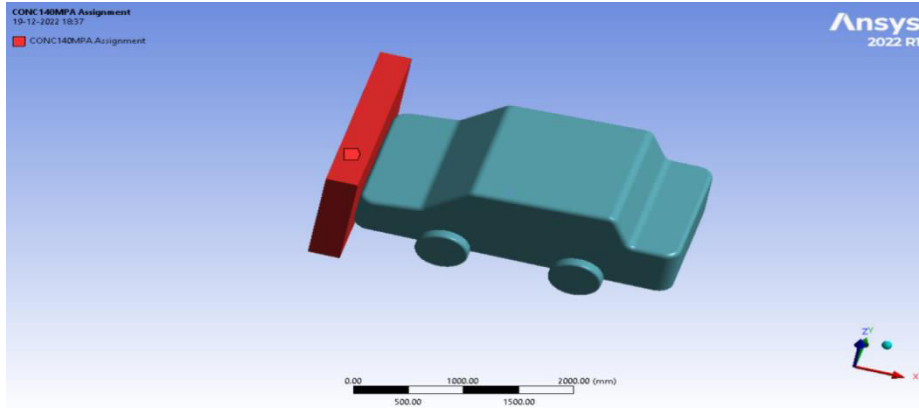

Figure 13: Concrete 140 Mpa assignment

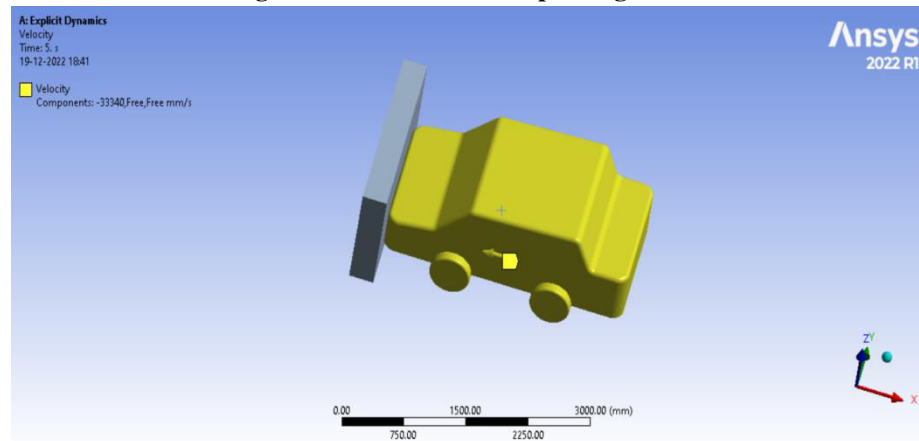

Figure 14: Input velocity (-33340 mm/sec)

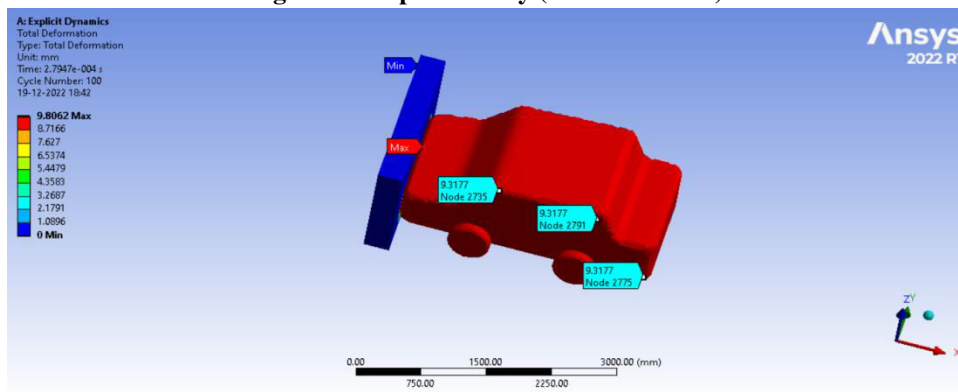

Figure 15: Total deformation

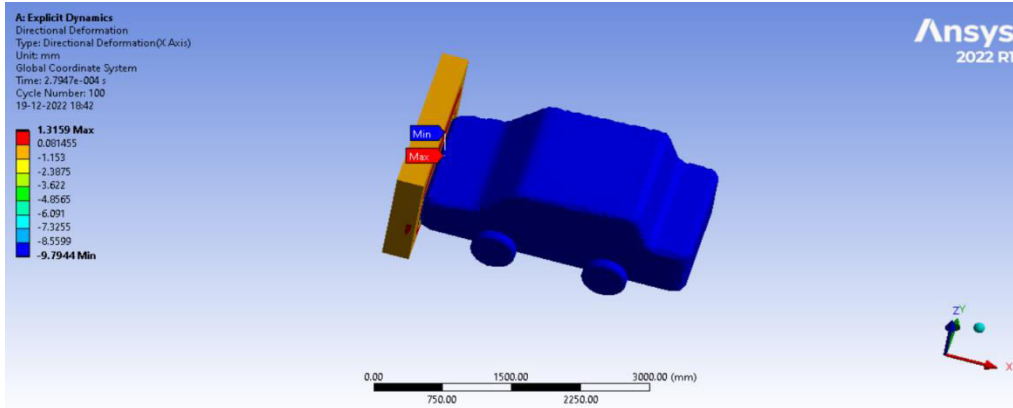

Figure 16: Directional deformation

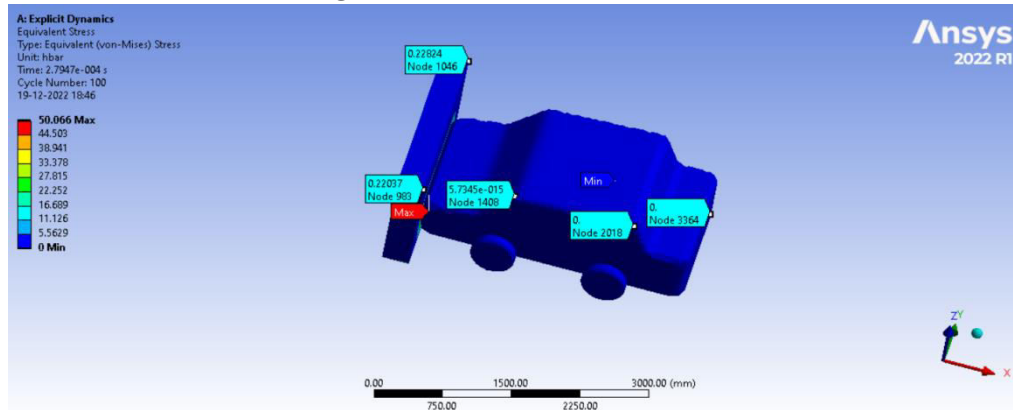

Figure 17: Equivalent stress

Explicit Dynamic Analysis of hybrid car using Carbon steel Material

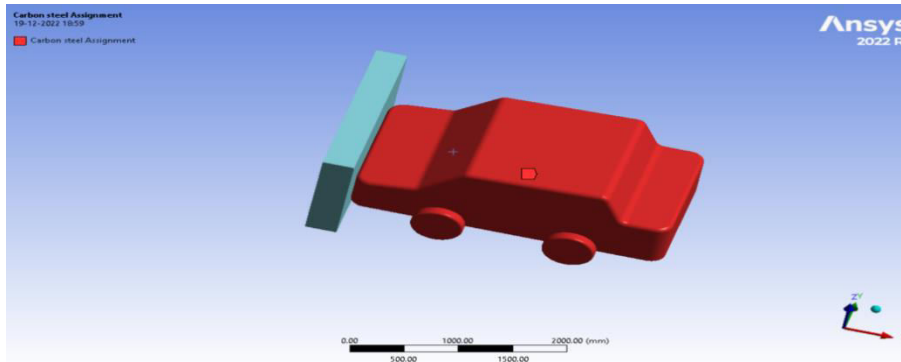

Figure 18: Carbon steel material Assignment

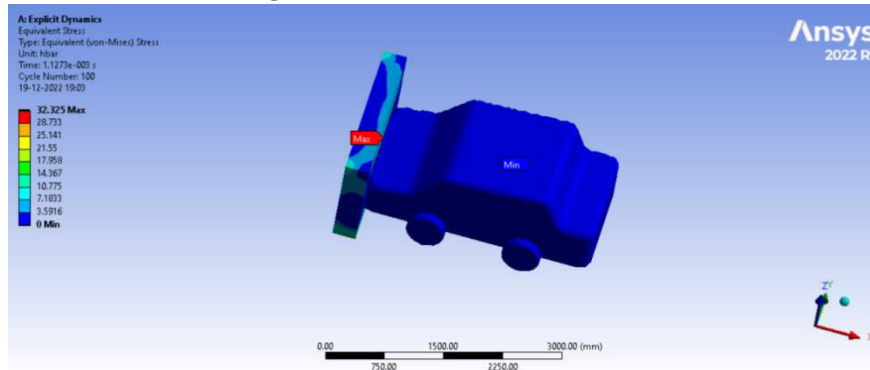
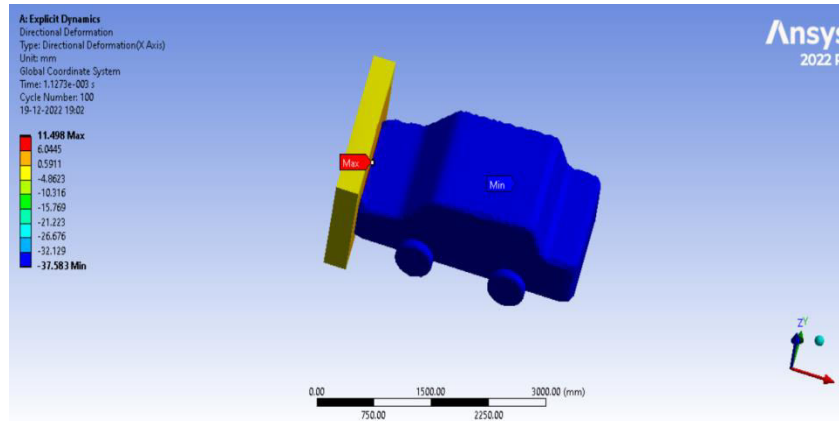
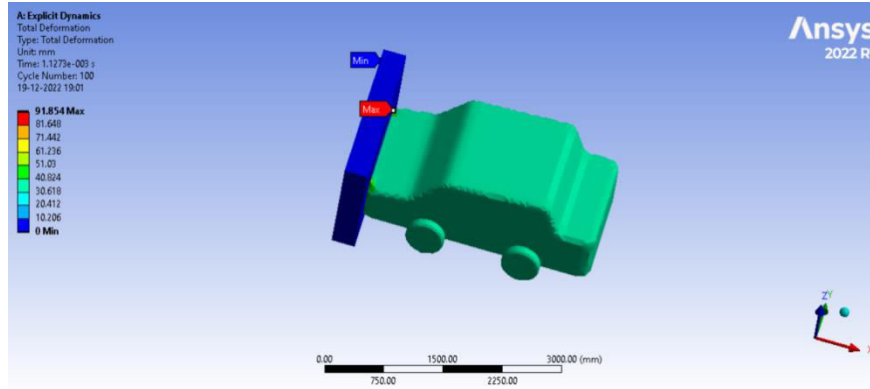
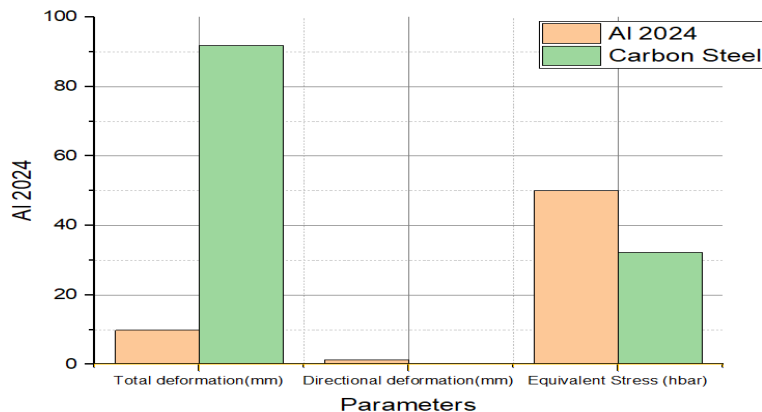

Table: Explicit Dynamic Analysis of Hybrid Drive Racing Car Using different materials Maximum deformations

Parameters	Al 2024	Carbon Steel
Total deformation(mm)	9.8062	91.854
Directional deformation(mm)	1.3159	11.498
Equivalent Stress (hbar)	50.066	32.325



Graph 1: Explicit Dynamic Analysis of Hybrid Drive Racing Car Using different materials Maximum deformations

Recent advances in hybrid and pure electric vehicles have created a trade-off between mileage and weight, so lightweight body parts are necessary. The increase in population density and the rapid development of transportation infrastructures, such as high-speed roads and multiple lines, have heightened the need for the critical safety assessment of vehicles produced. A simple car body structure was simulated in a frontal collision using ANSYS explicit dynamic method at 120km/h.

- In this Analysis various features of the racing car will be enhanced to make the whole car more aerodynamically efficient, by designing and modifying and the different parts of the car-body chassis, and analyzed
- The enhanced model will be made aerodynamically efficient by considering the contours of velocity and Different materials

Crash analysis shows that carbon steel material exhibits better material as compared to aluminum Alloys composite. But weight of carbon steel material is higher therefore building whole body with carbon steel would make it heavy and effect the mileage of vehicle

CFD ANALYSIS OF HYBRID CAR

The CFD model was constrained by the experimental data taken to the improve the model race car's efficiency on the road. Analysis of drag coefficient growth on car bodies was performed. The primary goal was to calculate the amount of drag experienced by the hybrid electric vehicle's body (HEV). Pressure points at various locations on the vehicle were used for the analysis, and speeds between 40 and 110 km/h were considered. In order to analyze the car's body, we used a CAD model that took into account the discretization of the mass and momentum equations. Input of automobile body-drag (CFD) and exporting it to finite element analysis (FEA) was used to estimate the drag in order to determine the value of aerodynamic drag in terms of drag forces and drag coefficient. Real pressure readings from pressure probes attached to the car's body were used to verify the values.

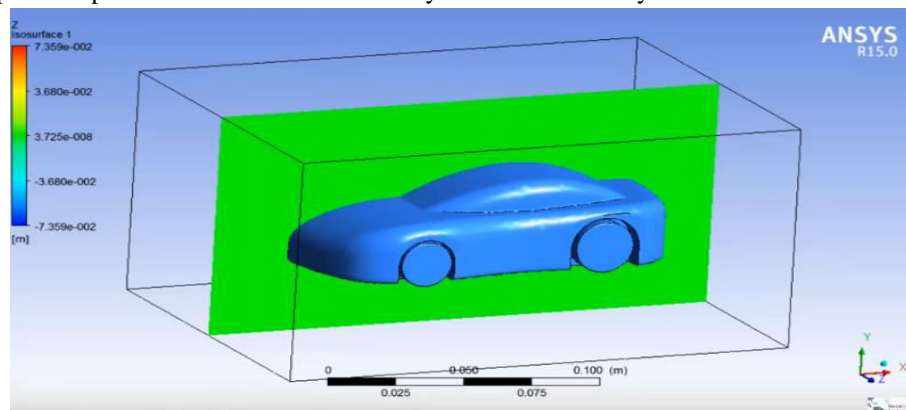

Figure 22: Minimum Velocity Gradients

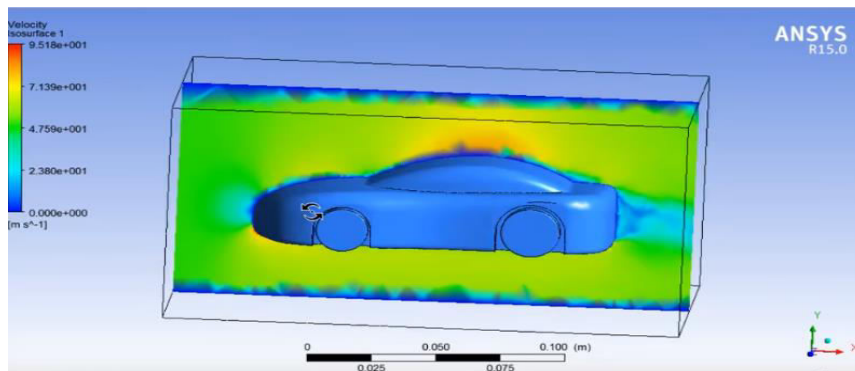

Figure 23: maximum velocity gradients

In a common moving car, there are constant forces acting to the car in which cause drag. It is dependent on the geometry of the body, motion of the body and the fluid in which it is travelling. The general forces found are drag and lift as shown in Figure 22 and 23.

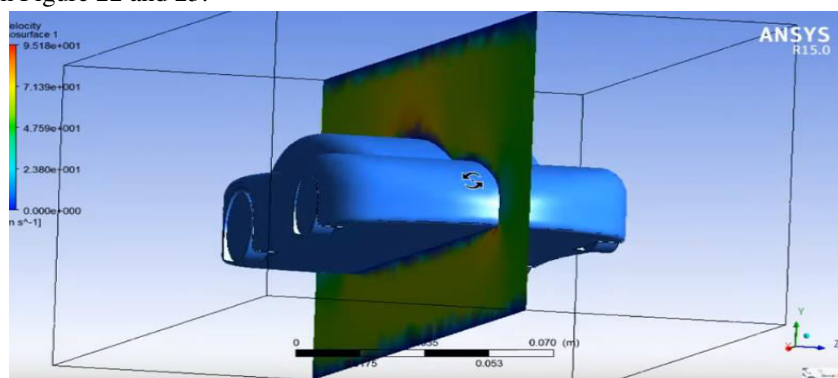

Figure 24: Equilateral velocity of the racing car drive system

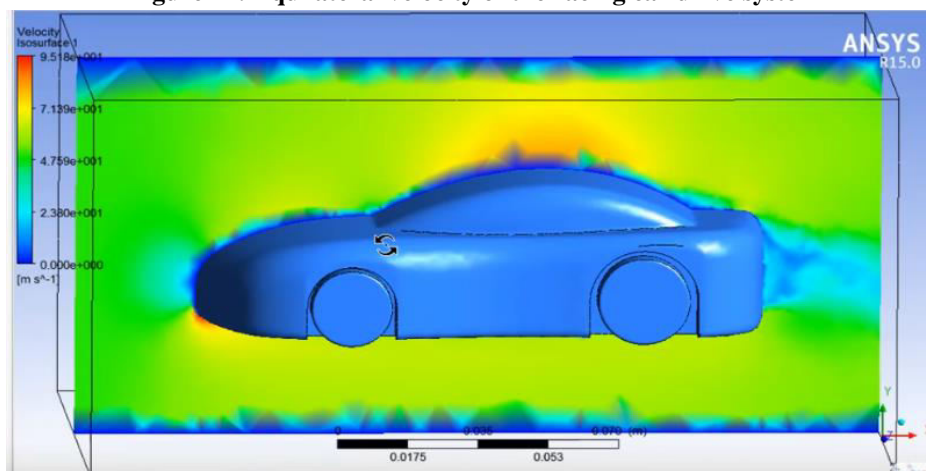

Figure 25: Distribution Velocity of The Racing Car

In this figure24,25 to Equilateral and Distribution Velocity that are not known with the resolution needed. Based on the Ahmed body for a generic car it can be divided into local drag contributions

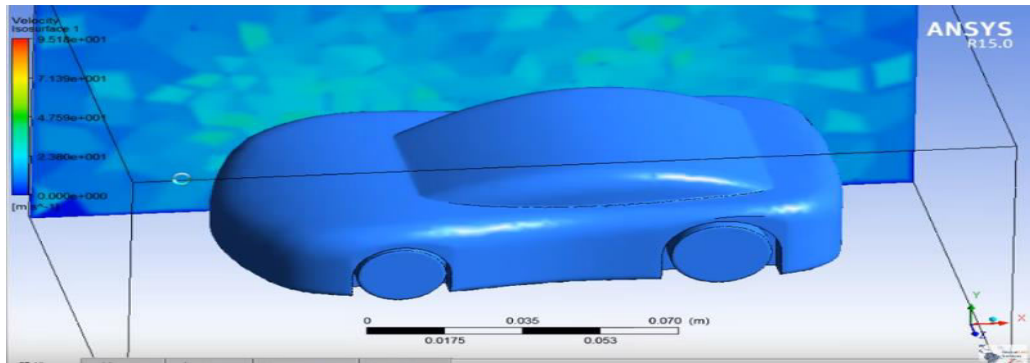

Figure 26: Complete Distribution of Velocity

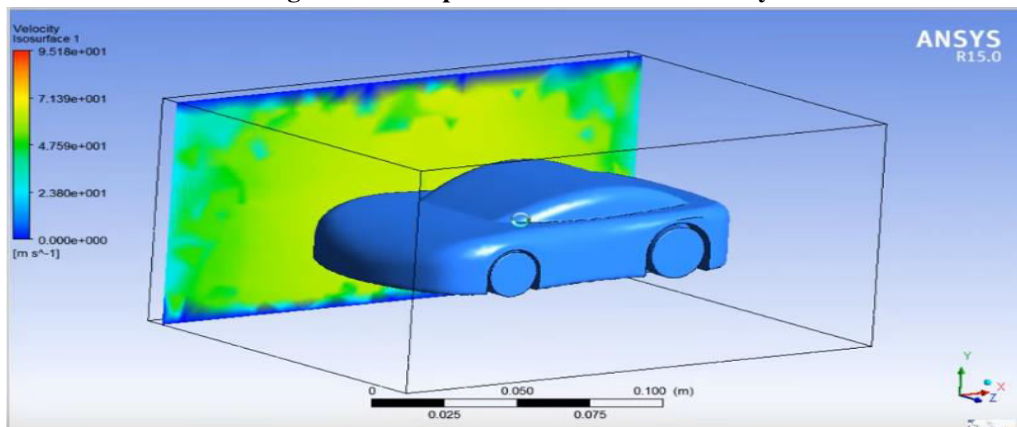

Figure 27: Minimum distribution velocity of racing car driving system

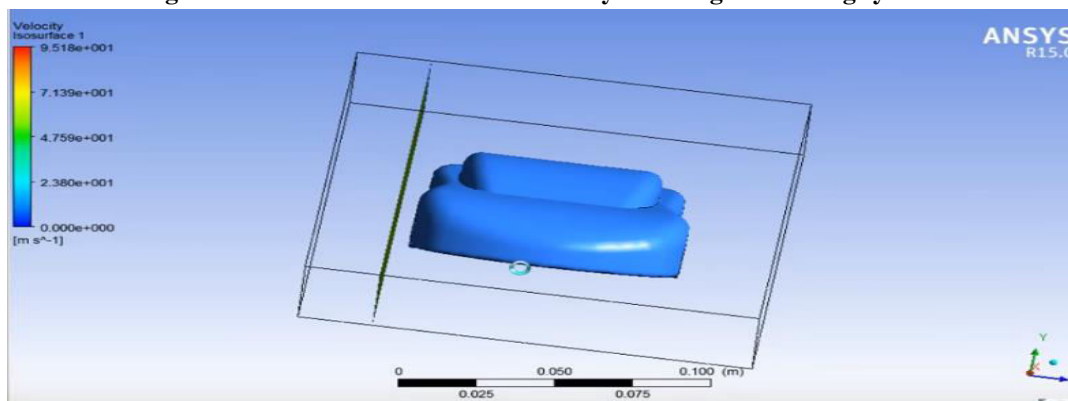

Figure 28: initial view of the hybrid drive racing car

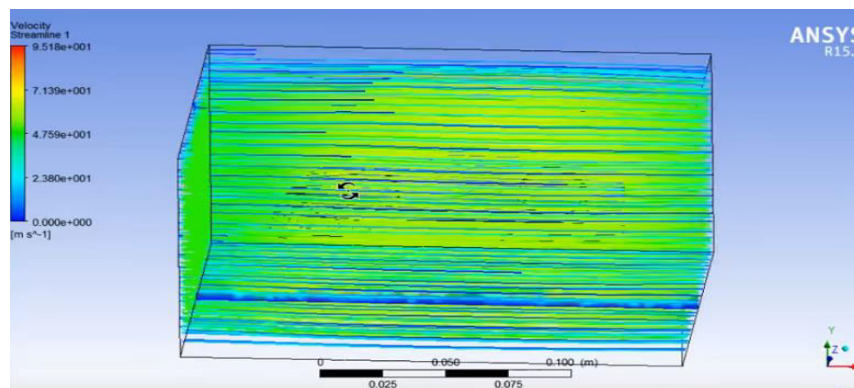

Figure 29: velocity of steam line

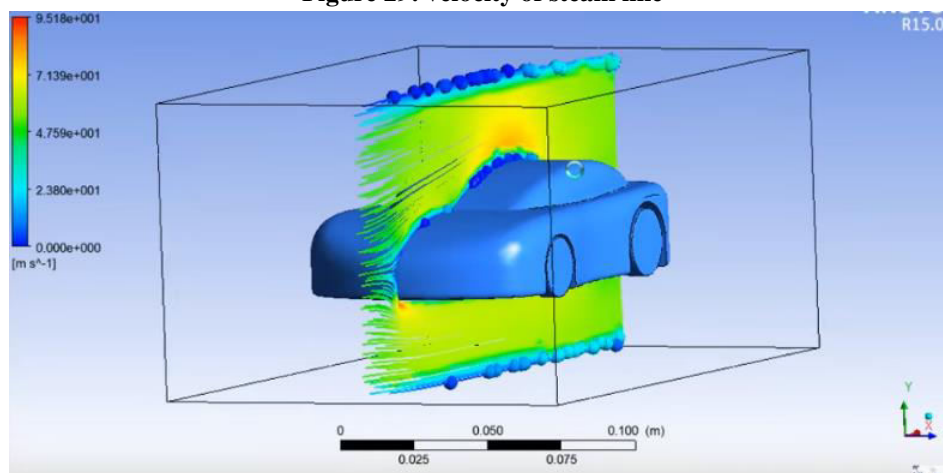

Figure 30: racing car velocity of steam line

Analytical velocity contour graphic for range measurement. Every velocity in the investigation yielded a relatively similar contour plot, as seen in the illustration. High and low speeds are represented by red and blue in the velocity contour plot. At the top speed of 110 km/h, a significant variation in the velocity contour is observed. There is a noticeable change in the blue area behind the body, known as the wake zone, where the turbulent flows were constructed following the laminar flow from the separation point above the rear windshield or the end boundary of the top. Reduced size of the blue "wake" section compared to other shades.

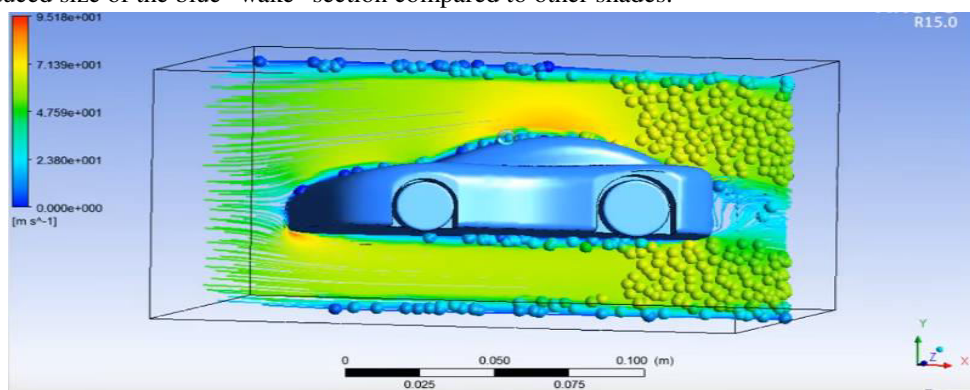

Figure31: maximum - velocity of the racing car

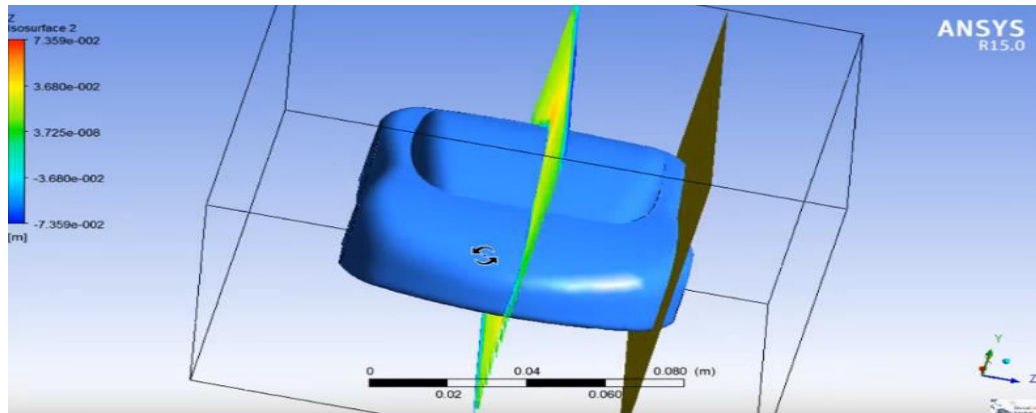

Figure 32: Minimum Velocity of Steam Line

The graphic demonstrates improved flow separation from the fore body's streamlining. The wake or separation region is easily distinguishable at 90 km/h, with the blue color having a more intense hue and a larger area than the others. That the growing drag force is affected by the high base pressure drag is established.

Table -2 Test Data

Source Fuel Efficiency	Source Fuel Efficiency	Source Fuel Efficiency
I.C.engine	Petrol	25 k.m./liter
Electric motor	Battery	12 km on full battery charge
Hybrid	Petrol and battery both	40

DISCUSSIONS:

The study's overarching goal was to alter previous works in the field by introducing a new design for the system's rotor (making a rectangular channel under the vehicle and installing the rotor at the channel's bottom) and by networking this system in the Gambit environment in a mode with the least pressure on the rotor at an inlet speed of 30 meters per second for air entering the channel:

- According to the increase in the system designing cost against the common vehicles, about 38 N/m torque was applied in flywheel rotation, where these few rotations can't meet the required propulsion for vehicle movement.
- Another critical aim is to reduce the pollution, produced due to increased fuel consumption. The rotor has more greenhouse gases.
- According to increased fuel consumption, there is no economic justification for the high cost of designing and producing such a system under the vehicle.
- As a result, the vehicle's front part needs more acceleration to move due to opposing power to movements.

CONCLUSIONS

The choice of components for hybrid drives is significantly influenced by the vehicle's mode of operation. The operating mode considers both the terrain and the vehicle's attributes. The ability of hybrid drives to store energy for use in unforeseen circumstances, such as emergencies, is a significant benefit. The combustion engine, which is the main source of propulsion, makes use of this fact by running at or near optimum efficiency. On grassy terrain, the quiet mode car should be able to cover 5 kilometers, while on asphalt, it should be able to cover roughly 10 kilometers. The car feels pressure from two main causes when it accelerates: rolling resistance and air resistance. Our primary objectives in this project were to estimate the drag coefficient and visualize the flow, both of which we accomplished successfully. At 40 to 110 km/h, the Proton body's aerodynamic drag coefficient was determined to be 0.326. The results of the investigation demonstrate that as the body's velocity squared, the aerodynamic drag—also known as the drag coefficient or drag forces—rose. Aerodynamic drag analysis uses a contour map of pressure and velocity to visualize data. The pressure and velocity contour graphs have the same visual pattern for each velocity.

There is the most fluctuation in the velocity figure between 90 and 110 km/h. We therefore discussed how to further this research in order to increase the effectiveness of the HEV model design.

FUTURE SCOPE

The switch from conventional to alternative fuels will go more smoothly if cars are equipped with hybrid technology. Users of the next-generation hybrid will benefit from lower gas prices and more possibilities to lessen their environmental effect when driving.

REFERENCES

1. Anjul Chauhan, LalitNaagar, Sparsh Chawla” Design and Analysis of Go-Kart”, International Journal Of Scientific Engineering And Technology ISSN: 2393-8609, 5 September, 2016.
2. D. Raghunandan, A. Pandiyan, Shajin Majeed.” Design and Analysis on Go kart chassis”, International Journal of Scientific Engineering and Technology ISSN: 2277-9655, 5 November, 2016.
3. Shithin PV and Uma Syamkumar Four Switch Three Phase Brushless Dc Motor Drive For Hybrid Vehicles International Journal of Mechanical Engineering and Technology, 5(11), 2017, pp. 65–75.
4. Sathish Kumar And Vignesh, “Design and Analysis Of An Electric Kart”, International Journal Of Research In Engineering And Technology EISSN: 2319-1163 | PISSN: 2321- 7308.
5. Perez, L.; Pilotta, E. Optimal power split in a hybrid electric vehicle using direct transcription of an optimal control problem. *Math. Comput. Simul. Tegucigalpa* 2004, 79, 1959–1970.
6. Viehmann, A.; Rinderknecht, S. Investigation of the Driving Comfort of the DE-REX Powertrain based on Vehicle Measurements. *Int. Fed. Autom. Control. Pap. Online* 2019, 52, 103–108.
7. Travis, E.; Torrey, J.; John, E.; Denise, M.; Jada, B. Tracked vehicle physics-based energy modelling and series hybrid system optimisation for the Bradley fighting vehicle. *Int. J. Electr. Hybrid Veh.* 2020, 12, 1–14.
8. Jing, L.; Xin-ran, W.; Lin-hui, L.; Ya-fu, Z.; Shu-zhou, Y.; Xiu-jie, L. Plug-in HEV energy management strategy based on SOC trajectory. *Int. J. Veh. Des.* 2021, 82, 1–17.
9. Zainab, A.; El, A.; Daniela, C.; Luis, M. Energetic macroscopic representation and inversion-based control of fuel cell in a series hybrid race vehicle system. *Int. J. Electr. Hybrid Veh.* 2022, 12, 197–213.
10. Wu, G.; Zhang, X.; Dong, Z. Powertrain architectures of electrified vehicles: Review, classification and comparison. *J. Frankl. Inst.* 2015, 352, 425–448.