

COMPARATIVE THERMAL ANALYSIS OF ENGINE CYLINDER FINS WITH DIFFERENT GEOMETRIES AND MATERIALS

¹Kolipaka Srinivasu,²Dr.Tvsrk Prasad,³Palaparathi Ravi Kumar,⁴Shaik Bashi

¹Assistant Professor,²Professor,³Associate Professor,⁴Student

Department of Mechanical Engineering

G V R & S College of Engineering & Technology, Guntur, AP

Abstract One essential part of the engine that must endure high temperatures and thermal stresses is the combustion chamber. The cylinder's surface fins facilitate faster heat transmission, which lowers the chamber's temperature. Fins are outside projections that increase the rate at which heat is convectively transported to or from an object. This results in an increase in the body's surface area and the rate at which heat is transferred. Engine fins have a high thermal conductivity, which enables fast heat transfer from the body to the surrounding fluid whether the fluid is cooling or heating the fin.

Since we know that surface area increases the intensity scattering rate, constructing a motor this large and complex presents a great deal of difficulty. The main purpose of the cooling blades is to utilise air to cool the motor chamber. This research aims to investigate the impact of modifying the fin's form on heat dissipation. The next step is to build the models by experimenting with various geometries, including triangles, circles, rectangles, and extended fins. The visual programme is called CATIA V5 R20. The analysis is performed using ANSYS 16.0 or R22. The counterweight body is usually constructed out of cast iron and aluminium 6061. Once the material has been determined, experimenting with various mathematical factors such as the cross-sectional area, boundary, length, thickness, etc., may improve the intensity and speed of the framework.

Keywords such as Engine, Fins, Convection, Geometry, Material, and Heat Dissipation

I INTRODUCTION

In the event of Gas-powered motors, ignition of air and fuel happens inside the motor chamber and hot gases are created. The temperature of gases will be around 800 to 1500°C. This is an exceptionally high temperature and may result into consuming of oil film between the moving parts and may result into seizing or welding of something very similar. Thus, this temperature should be decreased to around 150-200°C at which the motor will work most productively. A lot cooling is likewise not attractive since it diminishes the warm proficiency. Thus, the object of cooling framework is to keep the motor running at its most productive working temperature. It is to be noticed that the motor is very wasteful when it is cold and consequently the cooling framework is planned so that it forestalls cooling when the motor is heating up and work it achieves most extreme proficient working temperature, then it begins cooling. It is likewise to be noticed that: 20-25% of complete intensity created is utilized for delivering brake power (valuable work).

1. Cooling framework is intended to eliminate 30-35% of complete intensity
2. Remaining intensity is moved by exhaust gases.

The point of this undertaking is to figure out the impact of balance calculation and blade pitch on cooling of the motor. As the petroleum product holds are draining step by step, the spiralling fuel cost is pushing the innovation towards it cut off to give motors which are profoundly proficient and creates high unambiguous power. Air cooled motors are slowly transitioned away from and are being supplanted by water cooled motors which are undeniably more proficient in disseminating heat, yet in instances of bikes and certain different applications, air cooled motors are the main suitable choice because of space requirements. The intensity which is produced during ignition in a gas-powered motor ought to be kept up with at the most significant level conceivable to expand its warm effectiveness, however, to forestall the warm harm to the motor parts and the greases some measure of intensity should be taken out from the framework. In an ignition office of gas-powered motor, burning happen

at high temperature and strain because of which chances of cylinder seizure, overheating, chances of cylinder ring, pressure ring, oil ring and so on can be impacted. Abundance temperature can likewise harm the chamber material.

The pace of intensity move relies on the breeze speed, calculation of motor surface, outer surface region and the encompassing temperature. This is extremely high temperature and may result into consuming of oil film between the moving parts this temperature should be decreased to around 150-200 at which motor will work all the more proficiently. Heat move is arranged into three kinds. The first is conduction, which is characterized as move of intensity happening through mediating matter without mass movement of the matter. A strong has one surface at a high temperature and one at a lower temperature

This kind of intensity conduction can happen, for instance, through a turbine edge in a fly motor. The external surface, which is presented to gases from the combustor, is at a higher temperature than within surface, which has cooling air close to it. The subsequent intensity move process is convection, or intensity move because of a streaming liquid. The liquid can be a gas or a fluid; both have applications in aviation innovation. In convection heat move, the intensity is travelled through mass exchange of a non-uniform temperature liquid. The third cycle is radiation or transmission of energy through space without the fundamental presence of issue. Radiation is the main strategy for heat move in space. Radiation can be significant even in circumstances in which there is a mediating medium; a natural model is the intensity move from a gleaming piece of metal or from a fire. Convective intensity move is between the surfaces and encompassing liquid can be expanded by giving the meagre portions of metal called balances. Blades are likewise alluded as expanded surfaces. Whenever the accessible surfaces are deficient to move the necessary amount of intensity, balances will be utilized. Blades are produced with various sizes and shape relies upon the kind of utilization. Air cooling for an IC Motor is notable model for Air cooling framework in which air going about as a medium. Heat created in the chamber will

be dispersed into the air by conduction mode through the blades or expanded surfaces are utilized in this framework, which are consolidated around chamber.

An enormous sum heat produced in all burning motors (around 44%) gets away from through exhaust, not through fluid cooling framework (12%). Roughly 8% intensity energy is consumed by oil, which, while basically planned for oil, additionally fills in as intensity dissipator through cooler. Air-cooled motors are commonly stronger, yet they give greater straightforwardness, which enjoys benefits in wording administration part substitution.

The gas-powered motor is kind of motor in which fuel is scorched in burning chamber. The development high-temperature, high-pressure gases delivered by ignition acts straightforwardly on motor parts like cylinders, turbine sharp edges, and spouts. This power gets the part across significant distance, making usable mechanical energy in process. Despite the fact that air-cooled motors are being transitioned away from for additional proficient water-cooled motors, all Since air-cooled motors are more modest in weight and need less space, they are liked. To improve warm effectiveness, heat made during burning in an IC motor ought to be kept up with at more noteworthy level, yet some intensity ought to be taken out from the motor to limit warm harm. Inward motor ignition motors make hot gases from the consuming air-fuel blend inside motor chamber. The temperature gases will be somewhere in the range of 2300 and 500 degrees Celsius. The high temperature might cause oil covering to consume between moving parts, bringing about seizing or welding. As result, to work on motor's effectiveness, this temperature should be diminished. The intensity dissipative impacts balances utilized in motors by adjusting math and material have not been recorded, as per writing.

A balance surface that stretches out the item to expand the pace of intensity move to or from the climate by expanding convection. Expanding the temperature distinction between the item and the climate, expanding the convection heat move coefficient, or expanding the surface region of the article builds the intensity move. In some cases, it isn't affordable or changing the initial two options

isn't achievable. Adding a blade to the item, in any case, expands the surface region and can some of the time be prudent answer for heat move issues. Circumferential balances around the chamber of an engine cycle motor and blades connected to condenser containers of cooler are a couple of recognizable models.

II LITERATURE STUDIES

DR. I. SATYANARAYANA, PRANAY G et.al: In vehicle parts engine chamber is crucial part, is presented to high temperature assortments and warm nerves. To cool the chamber, edges are given on the external layer of the chamber to extend the speed of power move. The standard executed in the endeavour is to extend the force dispersal rate by doing warm assessment and using the working fluid of air. We saw that using of rectangular cutting edges, materials of both Al-composites have better power move for 2.5 mm thickness diverged from 3mm. To be sure, even three-sided balances have furthermore extreme focus move at 2.5 mm thickness and it is less diverged from rectangular yet using of three-sided sharp edges the substations of the body is less when appeared differently in relation to rectangular due to its math.

Arjun Vilay et. al. The exploration planned to decide the ideal size and state of the longitudinal rectangular balances, Tube shaped Pin Blade, including level warm conductivity. Because of the state of the progress, this study was finished with the deliberate greatest intensity move pace of the balance surface and negligible tension misfortune ready to go. The consequences of different estimations for Laminar and tempestuous with different Nusselt no. Subsequent to tackling the issue of post-handling, the X-Y plot and vector drawing the Laminar and violent streams including heat move rate and strain misfortune, in the wake of finishing the disclosure of different outcomes as layout figure.

Raviulla et. al. (2018) The essential target of the review is to survey by unmistakable math the intensity elements of chamber balances. Three aluminium combinations (A380, B390 and C443) are utilized in this examination. The various boundaries (i.e., cap shape and size) are respected in the exploration, shape (round and rectangular), and thickness (3 mm) by modifying the balance shape to three-sided structure, in this manner diminishing the blade body weight to build the intensity move rate and cap adequacy.

III METHODOLOGY USED IN THE STUDY

The below flow chart shows the methodology of the study in design and thermal analysis

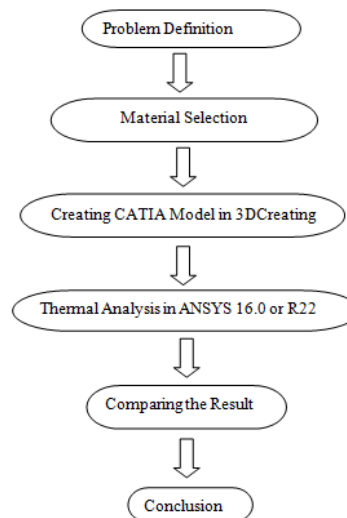

Chart 1: Methodology

Problem Definition

In the current task on thermal issues on auto fins were completed. The temperature conduct and intensity transition of the fins because of high temperature in the burning chamber. ANSYS work seat is used for examination. The examination is finished for various models of blades that are monetarily accessible now a days and a correlation is in this manner laid out between them. Likewise, the material is changed so that better intensity move rate can be acquired

Selection of Different Materials

The fins must have properties in below manner:

- Must have High Conductivity of thermal
- Should contain low specific heat
- Should be available at cheaper rates
- Should possess low density

Aluminium (Al) alloy 6061:

They available in non-ferrous types

- Specific Gravity (Low)
- Fabrication should made easy
- Corrosion resistance.

Cast iron: Cast iron is best material which fulfils the vast majority of the beneficial properties. It is by and large utilized for making motor block in view of its capacity of layered strength under warming or warm pressure.

Materials using According to Problem Definition and Selection of Different Materials

1. To plan chamber with blades for a motor by differing the calculation like Roundabout, Three-sided, Rectangular and thickness of the balances.
2. To decide transient warm properties of the proposed blade models.
3. To distinguish reasonable composite for the manufacture in light of results acquired from limited component examination and logical strategy.

Parameter and Forms of fins

Sl. No	Parameter	Forms
1	Annular Fin Type	Circular, Triangular Rectangular
2	Fin Thickness	1mm to 2 mm
3	Fin Material	Aluminium Alloy 6061, Cast Iron

IV SOFTWARE USED IN THE STUDY

CATIA

CATIA is a strong demonstrating instrument that joins the 3D parametric highlights with 2D devices and furthermore addresses each plan to-assembling process. As well as making strong models and congregations, CATIA likewise gives creating orthographic, segment, helper, isometric or itemized 2D drawing sees. It is likewise conceivable to produce model aspects and refer aspects in the drawing sees. The bi-directionally acquainted property of CATIA guarantees that the changes made in model reflected in the drawing perspectives as well as the other way around

1. 3D design
2. Part Modelling
3. Assembly Modelling
4. Surface Modelling

5. Finite Element Analysis

Models in CATIA Software

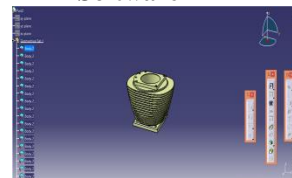

Fig 1: Final view of Circular Fin

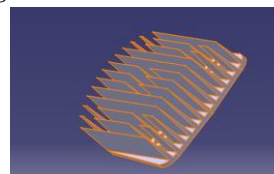

Fig 2: Final View of Triangular Fin

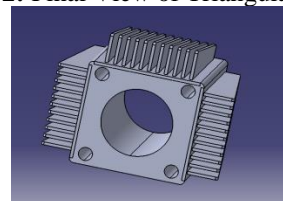

Fig 3: Final View of Rectangular Fin
V RESULTS AND ANALYSIS
CIRCULAR FIN
With al6061 material

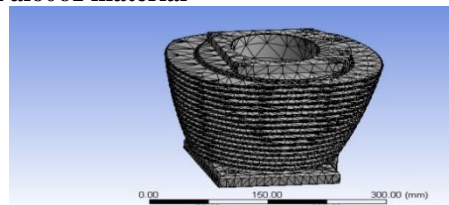

Fig 4: Circular Mesh model

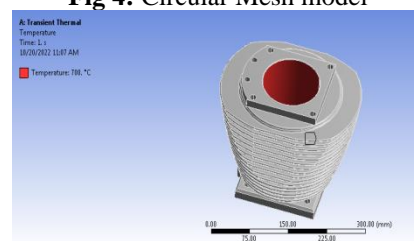

Fig 5: Transient Thermal Temperature of Circular Fin

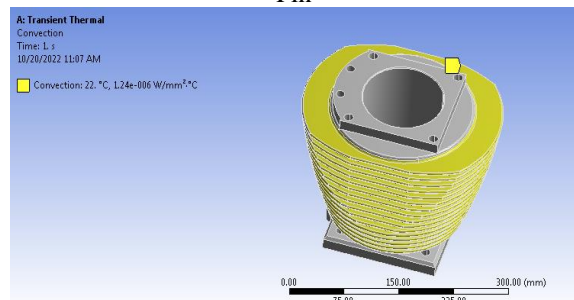

Fig 6: Transient Thermal Convection of Circular Fin

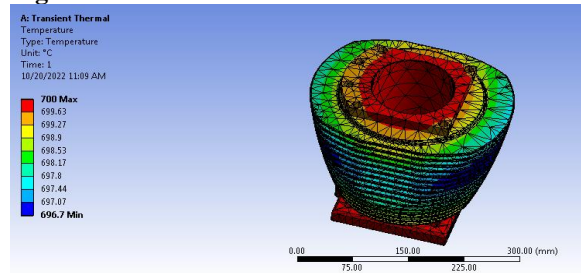
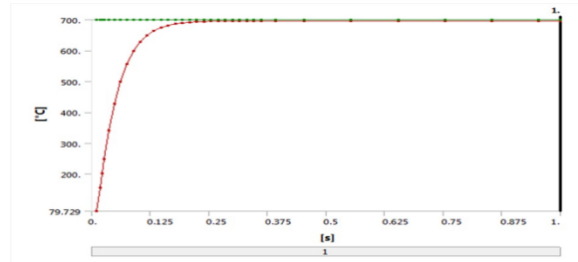

Fig 7: Temperature of Circular Fin



Graph 1: Temperature of Circular Fin

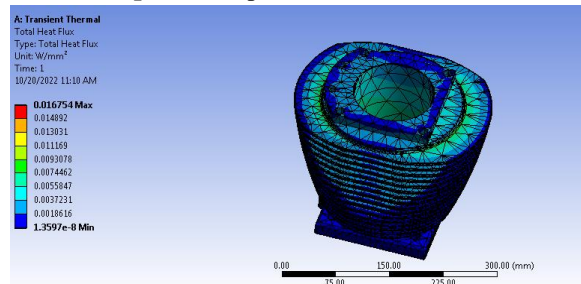
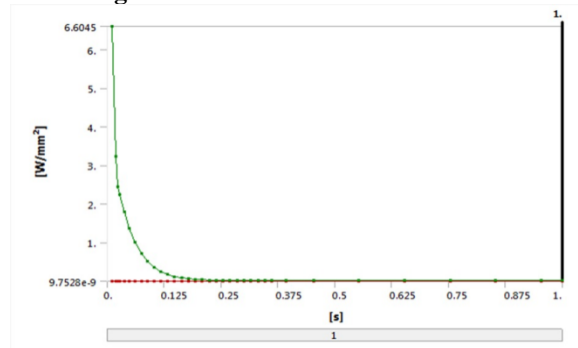

Fig 8: Total Heat Flux of Circular Fin



Graph 2: Result Total Heat Flux of Circular Fin

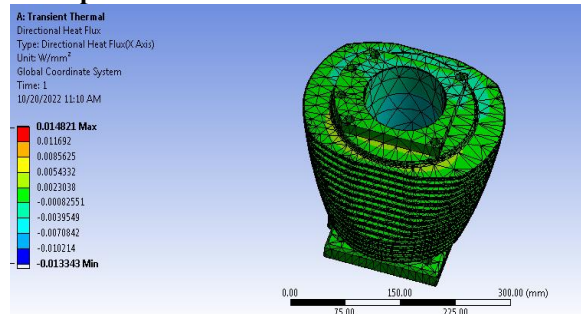
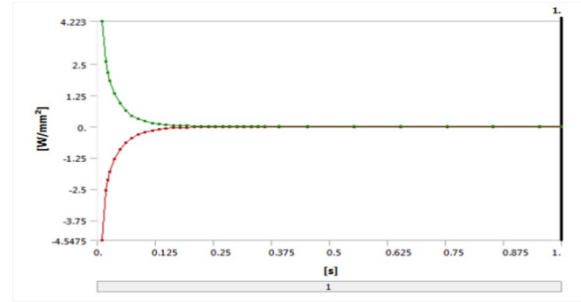

Fig 9: Directional Heat Flux of Circular Fin



Graph 3: Result Directional Heat Flux of Circular Fin

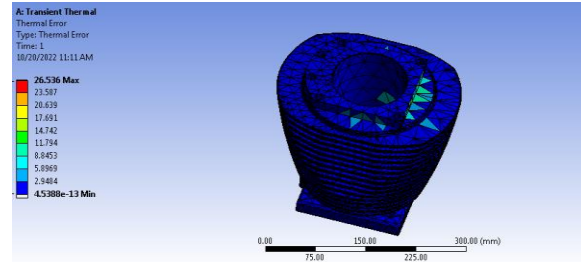
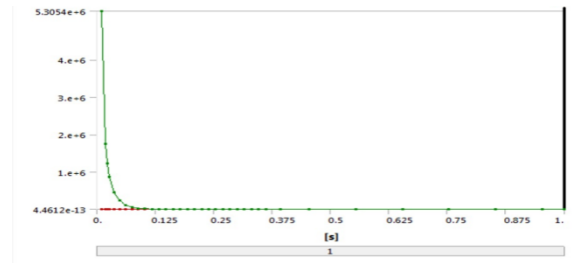

Fig 10: Thermal Error of Circular Fin



Graph 4: Result Thermal Error of Circular Fin With Cast iron

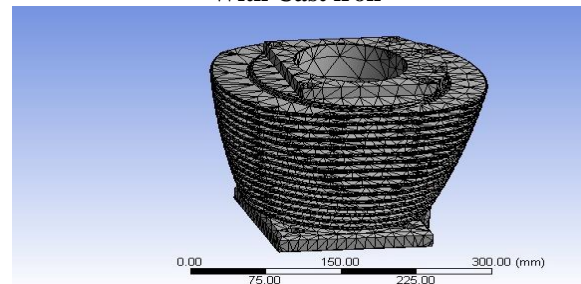

Fig 11: Circular mesh model

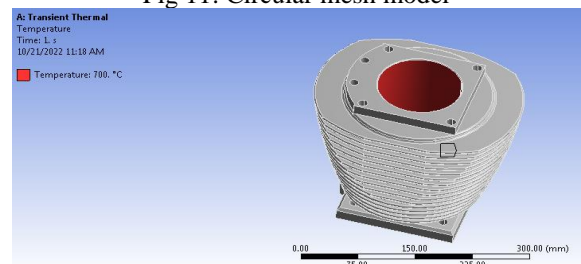

Fig 12: Transient Thermal Temperature of Circular Fin

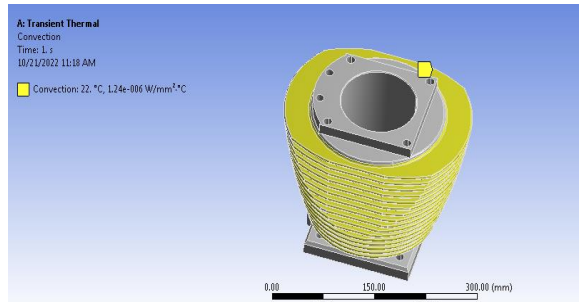

Fig 13: Transient Thermal Convection of Circular Fin

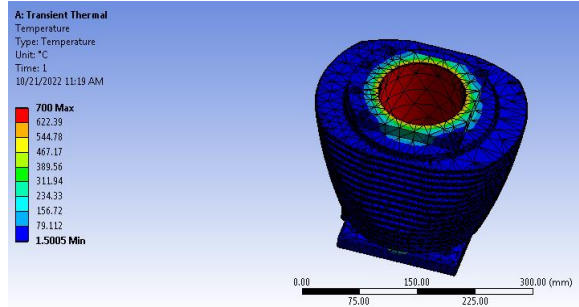
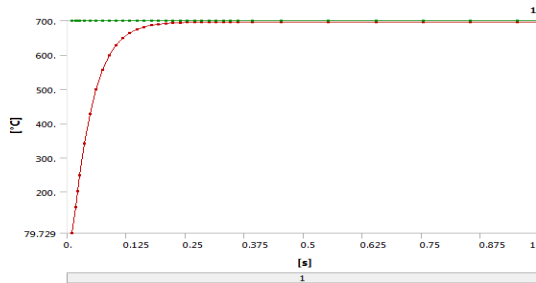

Fig 14: Temperature of Circular Fin



Graph 5: Result Temperature of Circular Fin

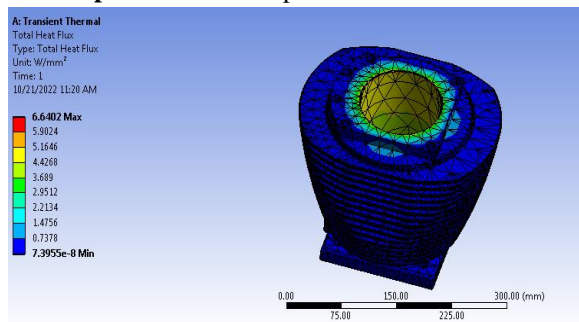
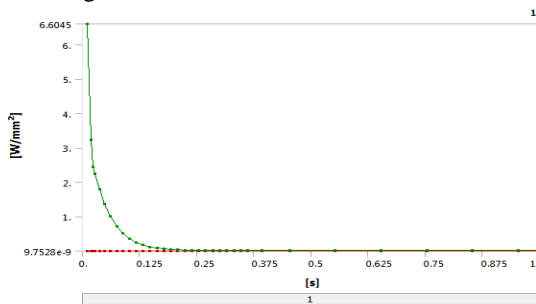

Fig 15: Total Heat Flux of Circular Fin



Graph 6: Result Total Heat Flux of Circular Fin

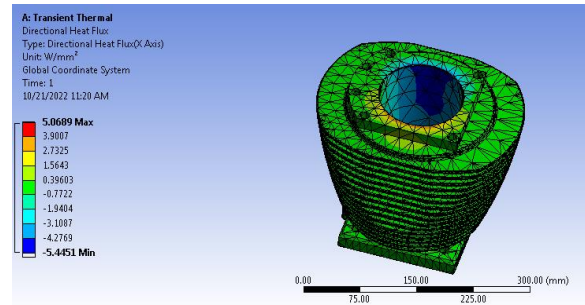
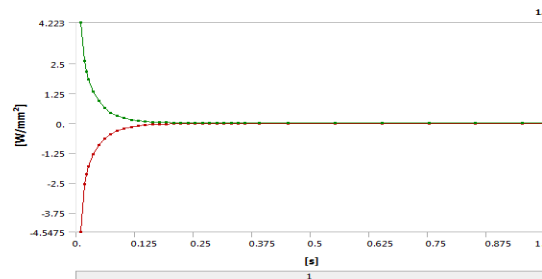

Fig 16: Directional Heat Flux of Circular Fin



Graph 7: Result Directional Heat Flux of Circular Fin

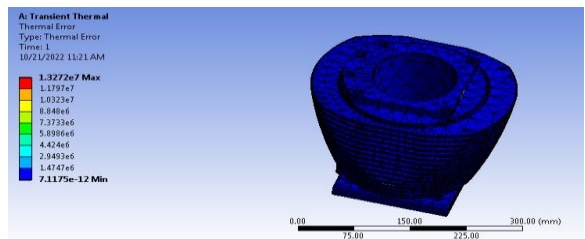
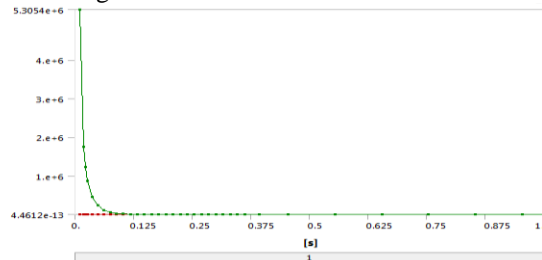

Fig 17: Thermal Error of Circular Fin



Graph 8: Result Thermal Error of Circular Fin

Triangular Fin

Al6061

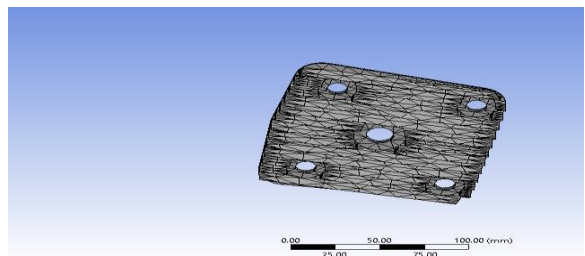

Fig 18: Mesh model

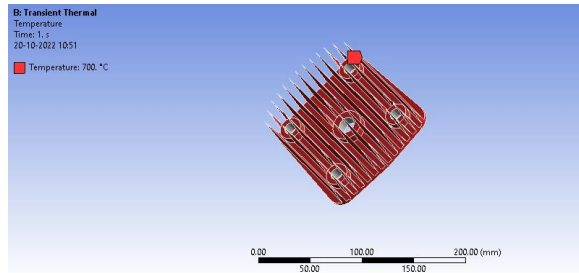

Fig 19: Transient Thermal Temperature of Triangular Fin

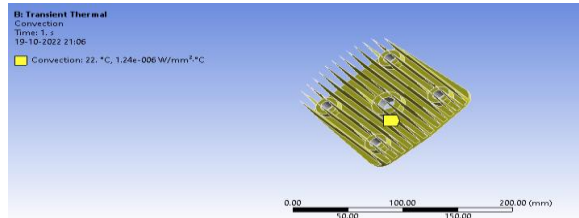

Fig 20: Transient Thermal Convection of Triangular Fin

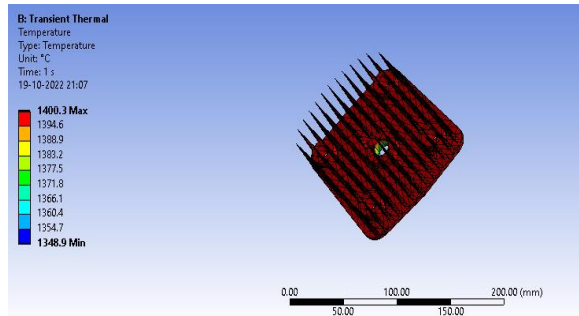
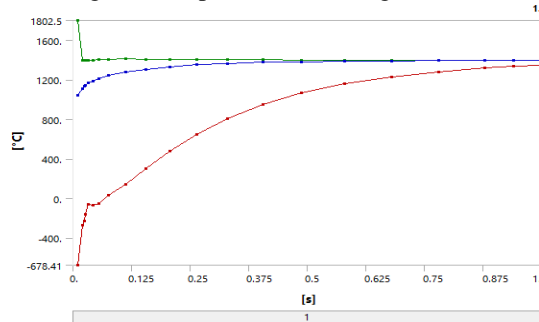

Fig 21: Temperature of Triangular Fin



Graph 9: Result Temperature of Triangular Fin

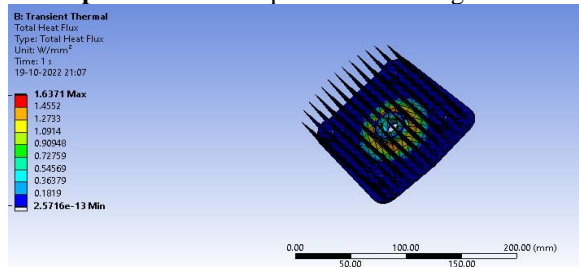
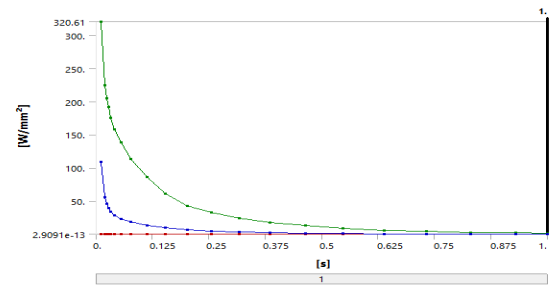

Fig 22: Total Heat Flux of Triangular Fin



Graph 10: Result Total Heat Flux of Triangular Fin

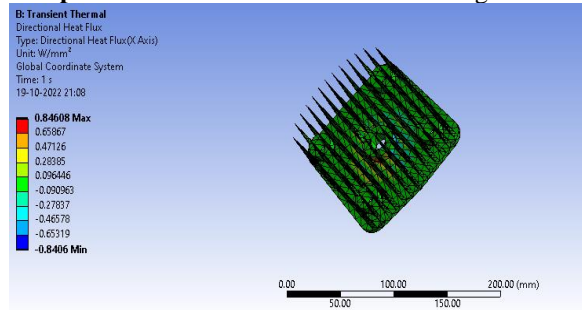
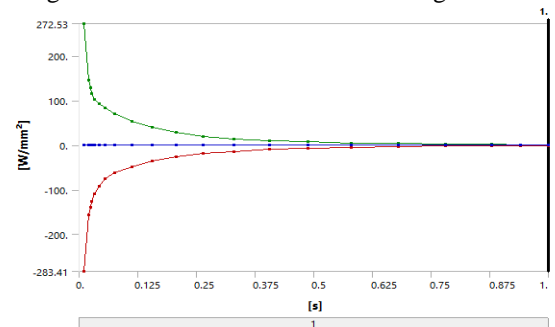

Fig 23: Directional Heat Flux of Triangular Fin



Graph 11: Result Directional Heat Flux of Triangular Fin

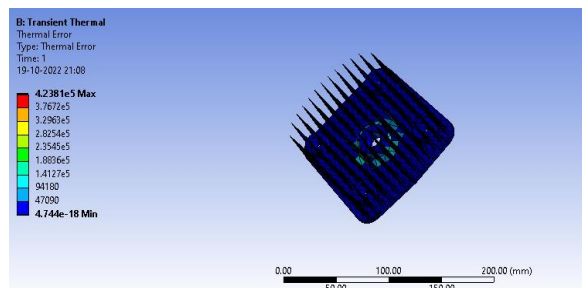
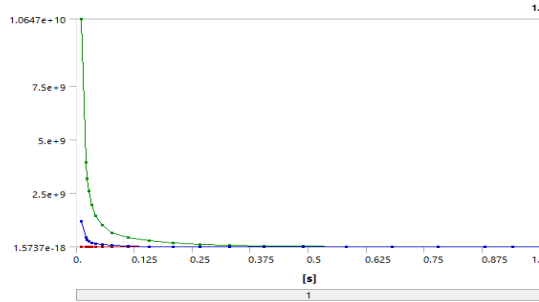
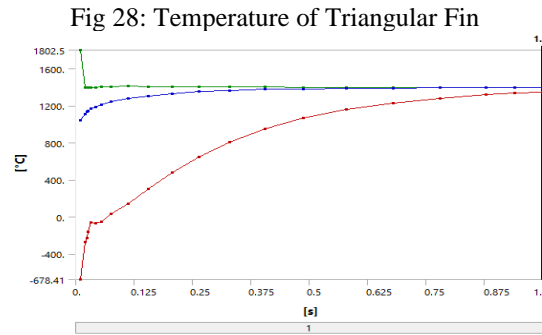

Fig 24: Thermal Error of Triangular Fin



Graph 12: Result Thermal Error of Triangular Fin Cast Iron



Graph 13: Result Temperature of Triangular Fin

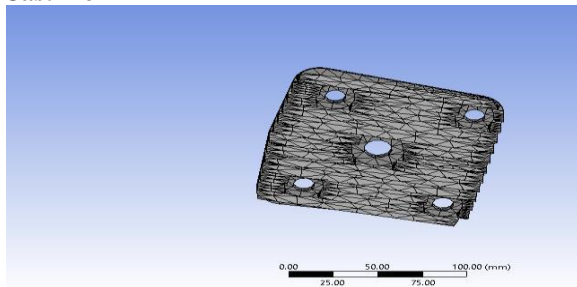

Fig 25: Triangular Mesh

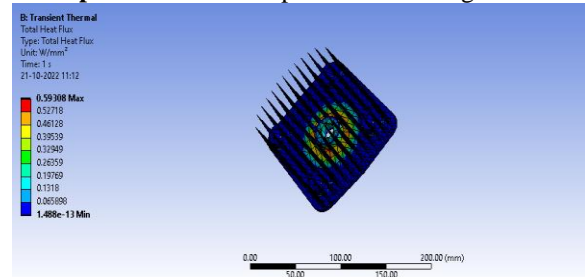

Fig 29: Total Heat Flux of Triangular Fin

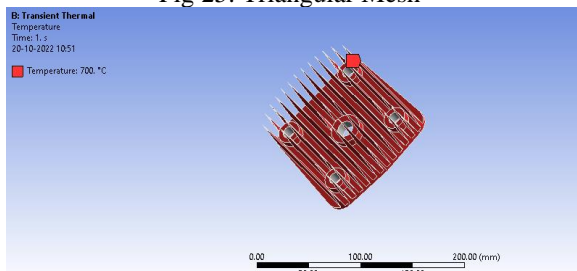
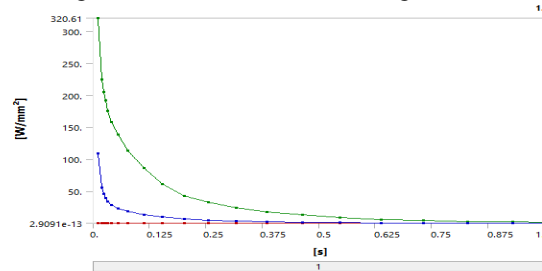

Fig 26: Transient Thermal Temperature of Triangular Fin



Graph 14: Result Total Heat Flux of Triangular Fin

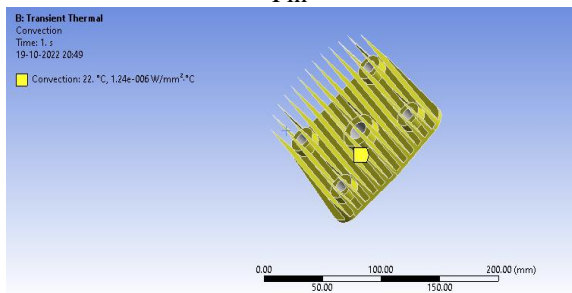

Fig 27: Transient Thermal Convection of Triangular Fin

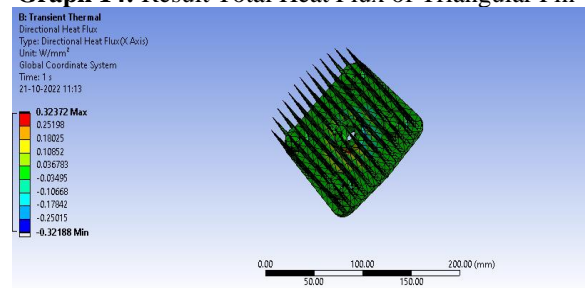
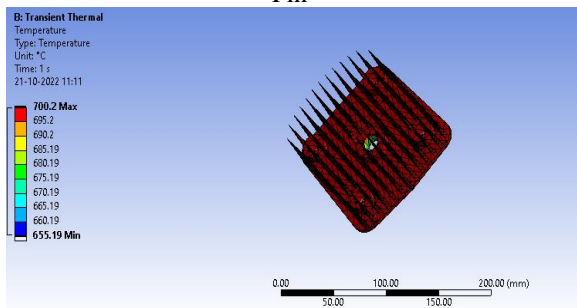

Fig 30: Directional Heat Flux of Triangular Fin



Graph 15: Result Directional Heat Flux of Triangular Fin

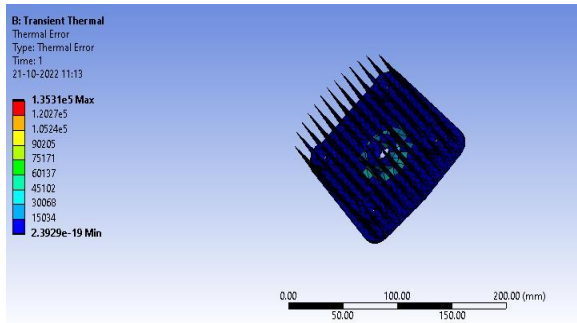
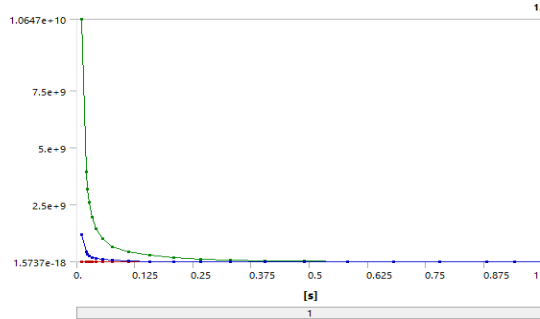

Fig 31: Thermal Error of Triangular Fin



Graph 16: Result Thermal Error of Triangular Fin Rectangular

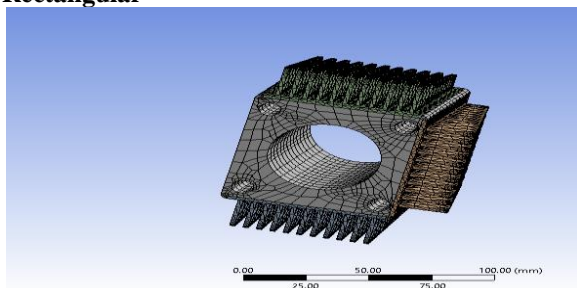

Fig 32: Mesh model

Al6061

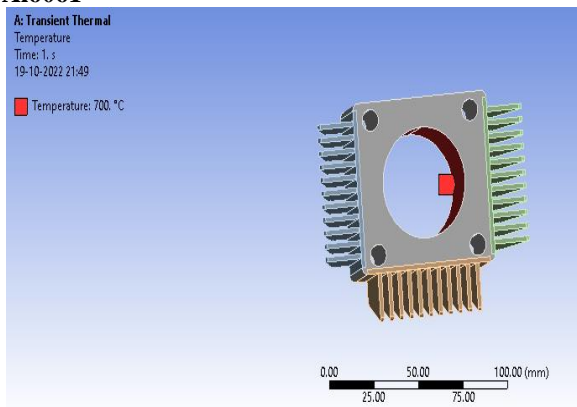

Fig 33: Transient Thermal Temperature of Rectangular Fin

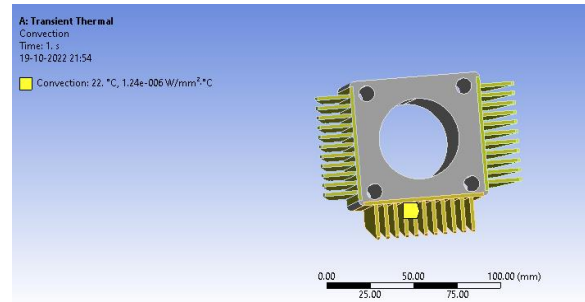

Fig 34: Transient Thermal Convection of Rectangular Fin

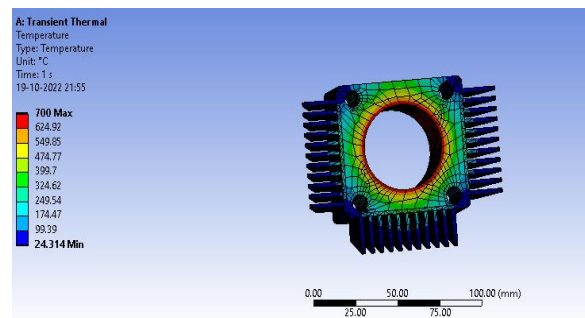
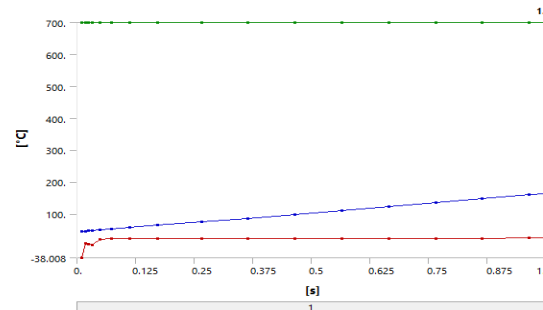

Fig 35: Temperature of Rectangular Fin



Graph 17: Result Temperature of Rectangular Fin

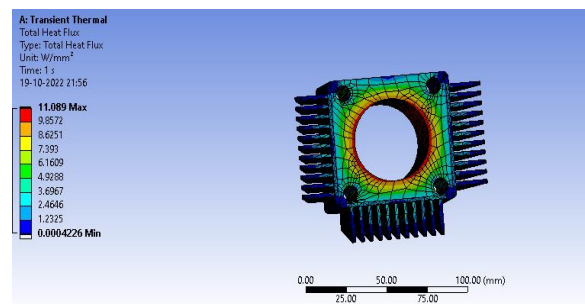
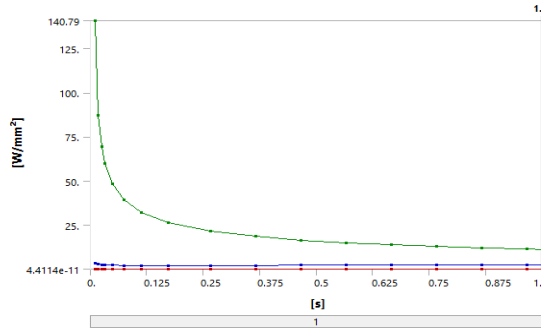
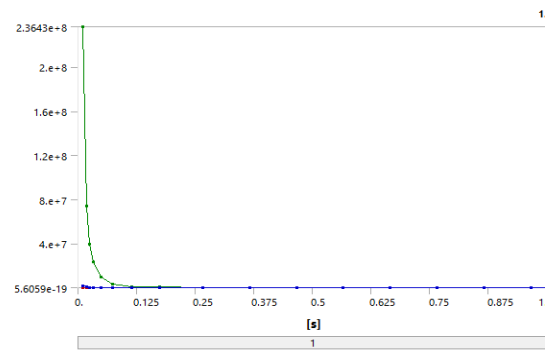

Fig 36: Total Heat Flux of Rectangular Fin



Graph 18: Result Total Heat Flux of Rectangular Fin

Fig 38: Thermal Error of Rectangular Fin



Graph 20: Result Thermal Error of Rectangular Fin

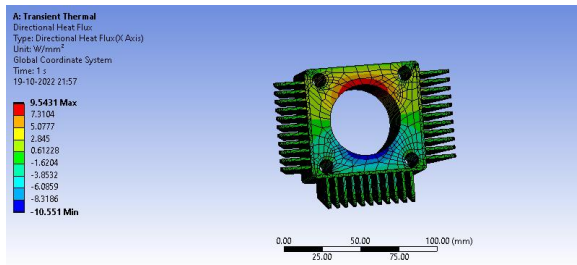

Fig 37: Directional Heat Flux of Rectangular Fin

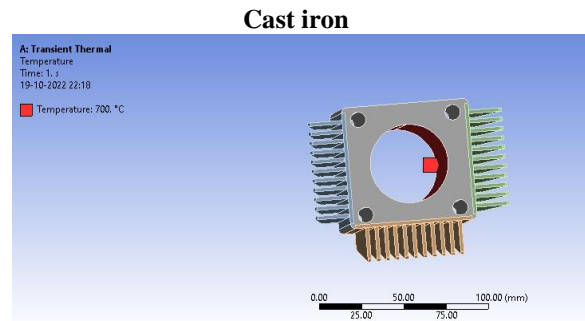
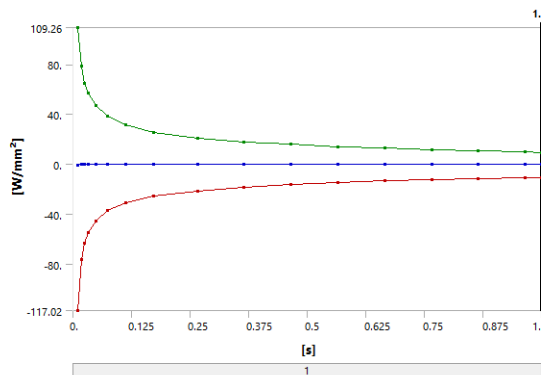

Fig 39: Transient Thermal Temperature of Rectangular Fin



Graph 19: Result Directional Heat Flux of Rectangular Fin

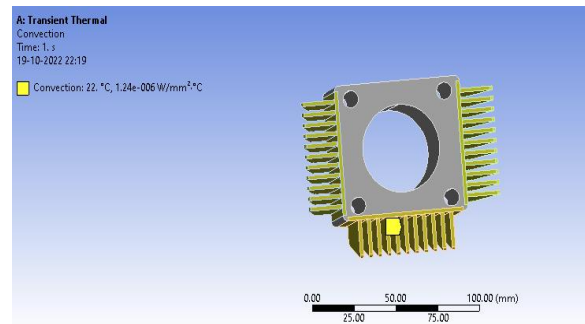

Fig 40: Transient Thermal Convection of Rectangular Fin

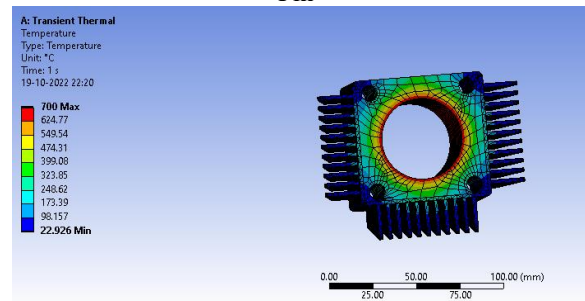
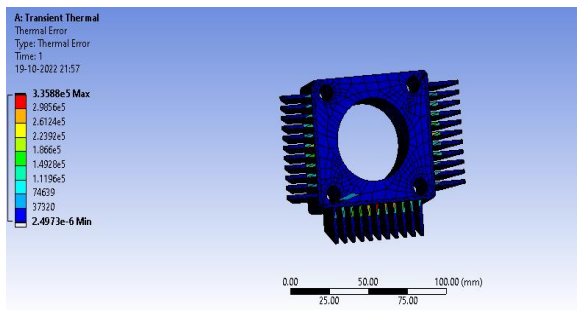
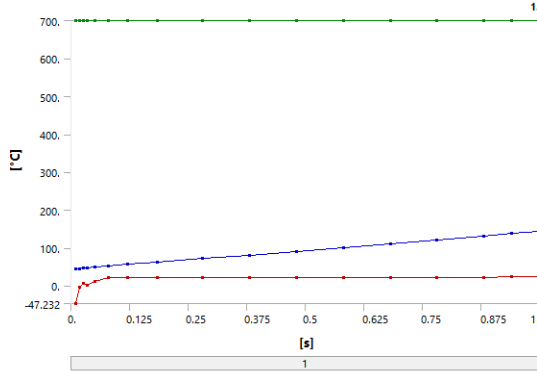

Fig 41: Temperature of Rectangular Fin



Graph 21: Result Temperature of Rectangular Fin

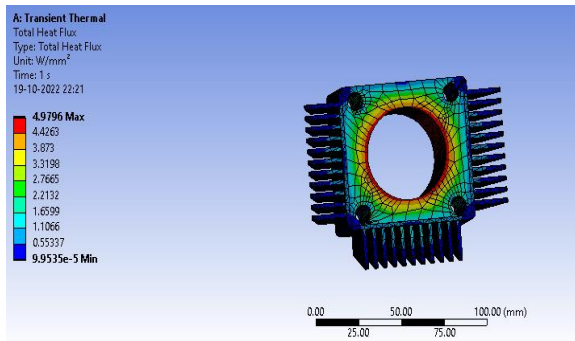
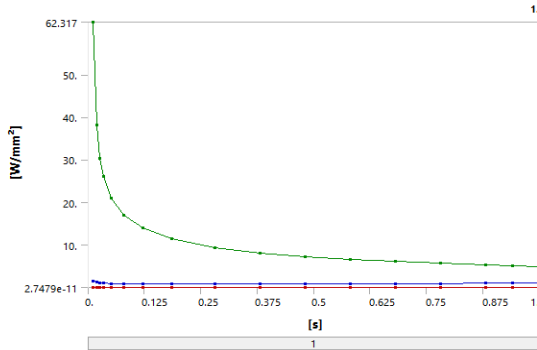

Fig 42: Total Heat Flux of Rectangular Fin



Graph 22: Result Total Heat Flux of Rectangular Fin

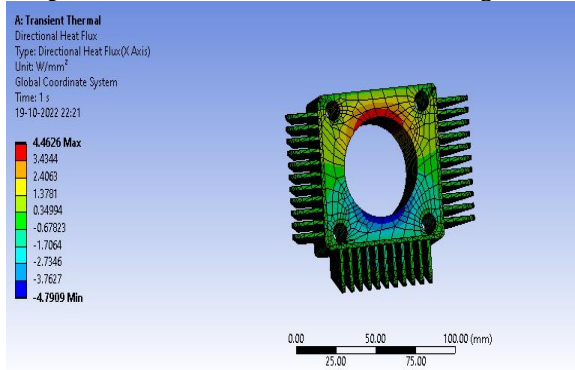
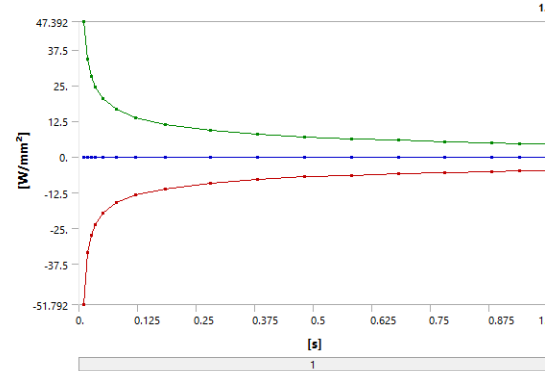

Fig 43: Directional Heat Flux of Rectangular Fin



Graph 23: Result Directional Heat Flux of Rectangular Fin

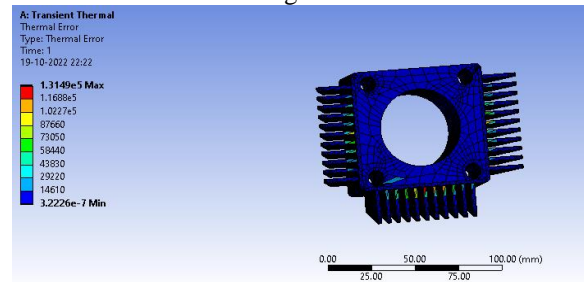
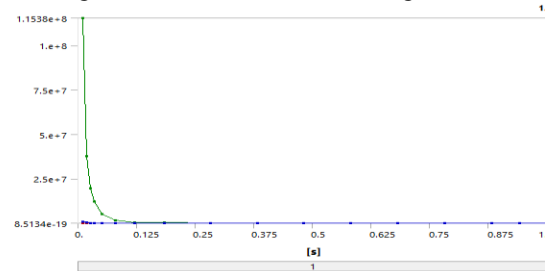

Fig 44: Thermal Error of Rectangular Fin



Graph 24: Thermal Error of Rectangular Fin

VI CONCLUSIONS

ANSYS V16.0 and a parametric model built with CATIA V5 are used to do a transient study of the thermal of the cylinder engine fin body in order to detect changes in temperature distribution and heat flow. In this study, thermal analysis was performed on engine cylinders including circular, triangular, and rectangular fins using an ANSYS workstation. Thermal experiment findings show that in order to use cast iron, there is a reduced thermal flux and a greater temperature in both the circular and triangular fins. Triangle fins are the greatest when compared to cylinders and rectangles. Statistics show that the heat flux rate is maximum when an aluminium alloy cylinder engine with fins is used. The cylinder engine fin is proposed in this thesis. Change the material by

the engine cylinder from aluminium alloy to cast iron for the optimal rate of heat evacuation from the cylinder via the fin.

REFERENCES

- [1] DR. I. SATYANARAYANA, PRANAY G et.al: Analysis and Design Rectangular and Triangular Fins using CFD by geometry variation, ISSN 2319-8885 Volume 05, Issue.31 October-2016, Pages:6554-6564
- [2] Arjun Vilay, Prem Shankar, Vivek Tiwari, "CFD Engine cylinder fin with various materials", International Journal of Advance Research, Thoughts and Developments in Innovation, Volume 4, Issue 3, 2018.
- [3] Raviulla, Ashish Muchrikar, "Transfer rate of heat by Cylinder Engine Fin by its geometry difference variation and also Materials", International Journal of Science and Research (IJSR), Volume 7 Issue 1, January 2018.
- [4] M. RAJESH, "Design and optimization of engine cylinder fins by varying Geometry and material with thermal analysis", International Journal of Core Engineering & Management, Special Issue, NCETME -2017.
- [5] D. Madhavi, D. Dev Singh, "Analysis and Design of Cylinder Engine of Fin by varying parameters", International Journal & Magazine of Engineering, Technology, Management and Research, July 2018.
- [6] Mahendra Kumar Ahirwar, Ravindra Mohan, Jagdish Prasad, "I.C. Cylinder Engine Fins of Analysis by Transient Thermal Using ANSYS Software", International Research Journal of Engineering and Technology (IRJET), Volume 05, Issue: 02, Feb-2018.
- [7] Pradeep Kumar, Animesh Singhai, "Transient Thermal Analysis of Cylinder Fins with Holes by Using Different Materials", IJIRT, Volume 5, Issue 1, June 2018.
- [8] Mr. Manir Alam, M. Durga Sushmitha, "Design and Analysis of Engine Cylinder Fins of Varying Geometry and Materials", International Journal of Computer Engineering in Research Trends, Volume 3, Issue 2, February-2016, pp. 76-80.
- [9] K. Ashok, T. V. Seshi Reddy, S Satpagiri, "Temperature and flux rate variation on Cylinder engine head using ANSYS", International Journal of Advanced Research Foundation, Volume 2, Issue 5, May 2015.
- [10] P. Sai Chaitanya, B. Suneela Rani, K. Vijaya Kumar, "Analysis of Cylinder Engine Fins by changing Shape and Material", IOSR Journal of Mechanical and Civil Engineering (IOSR-JMCE), Volume 11, Issue 6, 2014.