

IMPROVING BATTERY LIFE OF E -VEHICLE USING SUPER CAPACITOR AND REGENERATIVE BRAKING

¹Sandeep Neeradi,²Ravi Maloth,³Subhash Mulugu,⁴Fathima Butule

³Associate Professor,^{1,2,4}Assistant Professor

Department Of EEE

Kshatriya College of Engineering

ABSTRACT:

Nowadays, for the development of regenerative drive system for the elevators, power and energy variation are the main motivations. So, there is a need to save energy which is wasted during normal operating condition of elevator. Aim of this paper is to adjust the acceleration and deceleration rate and speed for maximizing the regenerative capability of the drive system and hence to improve the elevator efficiency. At the time when the elevator machine operates as the generator, the energy due to braking is accumulated in a super-capacitor bank for temporary storage purpose and when the elevator machine operates in motoring mode the braking energy can be reused. Whatever the energy generated during braking is either returned back to the grid via converter or accumulated in a super-capacitor for further use in motoring operation. The proposed system has been simulated in a MATLAB. For charging the super-capacitor, the charging circuit model is prepared using PWM technique.

Keywords— super-capacitor, elevator motor drive, braking energy, PMAC motor, dc-dc converter.

I.INTRODUCTION

In recent years, because of the rapid increase in demand of energy which will be doubled in the future, it becomes imperative to save the energy in any form and by any means. This also applies to the elevator being one of the sources of energy consumption. There are various ways for the elevator to consume less energy.

- Efficient passenger transportation for neglecting unnecessary journeys.
- Proper use of technology suitable for building needs.
- Use of lighter material, instead of using heavy material.
- Use of efficient motors and drives.
- Use of efficient storage device to store the electrical power in the form of energy.

Later solution is the most efficient option to save the wasted power in the form of energy. For this purpose super-capacitor, flywheel, battery, capacitor, etc are the common storage devices. Out of these, super-capacitor has

been preferred because of its advantages of having higher energy and power density. As it has better physical property, it does not loose accumulated energy.

Elevator has been introduced as the second most power consuming drive in a common room sharing areas of a building. The lifts which are equipped with regenerative drive system can capture the regenerated power for feeding it back to the grid. Although, a regenerative system having combination of rectifier and inverter is a best solution, it is costlier compared with the dc-dc converter with super-capacitor bank. There might be an improved technology having an inverter operating only in a braking mode for feeding the regenerated energy to the grid.

In this emergent world, it becomes very concern to reduce the energy consumption of the device. So it is obvious to increase the energy efficiency of the device. Energy efficiency of the elevator drive can be improved by storing the power regenerated during braking at the time when the elevator is lifted up with light load and lifted down with

heavy load. The proposed system uses super-capacitor bank as a storage device to store the regenerated energy. During the period of maximum power demand and transient operation this energy is fed back to the grid. In the loaded condition, elevator always starts and stops, hence it consumes more power. super-capacitor is being used when there is a need for sharing a maximum power. The super-capacitor storage device becomes an attractive solution in the elevator operation compared with other energy storage systems such as battery. super-capacitor prefers over batteries, such as: It doesn't require more preservation because it has less wear and tear. It is able for high power management by having a small resistance. It is capable for more charging and discharging cycles.

In this paper, non-isolated bi-directional dc-dc converter is used which has a combination of step-up and step-down stage connecting in antiparallel. Brushless dc motor or PMAC motor is used which has many advantages over other type of motors.

II. ENERGY SAVING OPERATION IN ELEVATOR

A. Proposed System

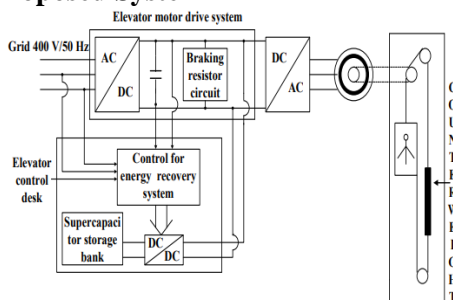

Fig. 1. System configuration.

The proposed system comprises a cabin, elevator motor drive, super-capacitor bank, rectifier, inverter and dc-dc converter. The information required for the cabin movement is obtained by elevator control desk. Braking resistor is used for dissipation purpose after

the full charging of super-capacitor. super-capacitor storage bank stores the regenerated power for temporary purpose and when power failure in grid occurs, this super-capacitor fed energy back to the grid by a dc-dc boost converter.

B. Energy Flow Diagrams

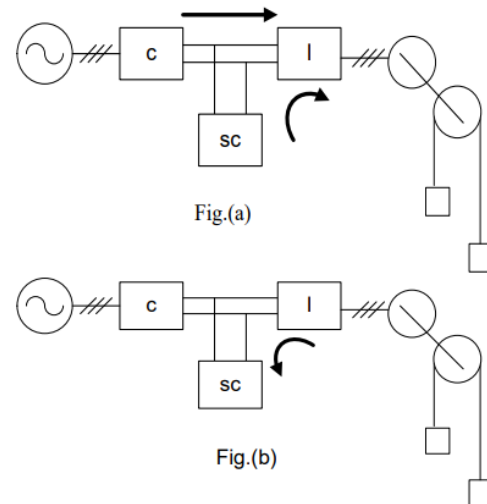

Fig. 2. Flow of energy in a drive.

Fig. 2(a) indicates the energy flow from grid and super-capacitor towards the motor. When SC-bank is not charged enough it gets discharged in motoring status in a combination of grid. Fig. 2(b) shows that super-capacitor gets charged from regenerated power.

C. Bi-Directional Dc-Dc Converter

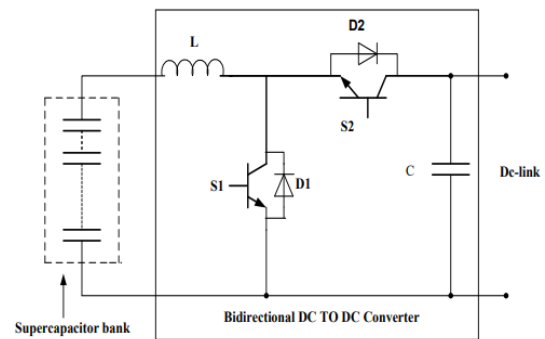

Fig. 3. Bidirectional dc-dc converter with SC-bank.

The dc-dc converter is an electronic power converter which interfaces the voltages of dc-

link and super-capacitor. During both charging and discharging of SC, this converter enables the power transfer in both the directions. During charging of SC, it operates in buck mode and during discharging, operates in boost mode. Using buck circuit regenerative braking has been completed and using boost circuit motoring operation has been completed. The non-isolated dc-dc converter has been chosen because of its advantages of high efficiency, high reliability and low power loss. Also it is less expensive and small in size as compared with other converters.

D. PMAC Motor Fed from an Inverter

The brushless dc motor drive or PMAC motor drive employs an inverter and ac motor. In this drive system, stator windings are connected in star and PM is on rotor. Permanent magnet ac motor is very similar to the dc motor. Induced voltage is proportional to the speed in a PMAC motor same like dc motor. As in dc motor, torque directly varies with armature current, here also torque is proportional to the armature current. In this motor, stator and rotor field remains stationary with respect to each other. As it does not requires brushes and maintenance, it is called as brushless dc motor. In PMAC motor, inverter is used in place of brushes and commutator in dc motor.

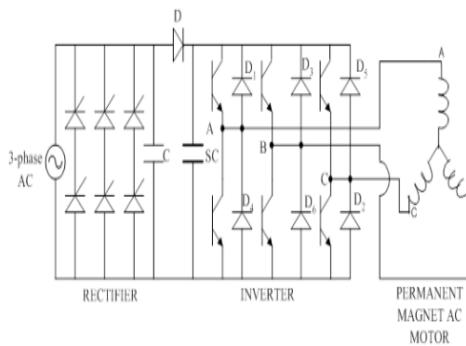

Fig. 4. PMAC motor fed from a voltage source inverter.

III. SIMULATION MODEL AND RESULTS

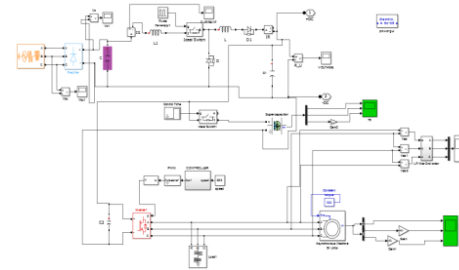

Fig. 5. Simulation model of elevator drive with super-capacitor.

In this project, a permanent magnet AC motor with 50Hz, supply voltage 400V has been used. According to [7], super-capacitor having capacitance of 4.5F with series resistance 2.4mΩ has been used. The super-capacitor bank contains 100 unit cells which are connected in series for getting rated voltage. super-capacitor bank voltage is 150~250V. Thus whole stack of super-capacitor consist of 450F.

Model consists of power supply, rectifier, dc-dc converter, super-capacitor and motor load. More number of super-capacitor has been connected in series to have a high voltage and lesser capacitance. Control timer is used for controlling a time for charging of a super-capacitor. The charging time is from 0.7sec to 1.2 sec. The dc voltage obtained in buck circuit operation is around 185V as shown in fig.6. From the simulation waveform of a super-capacitor bank it can be concluded that during the charging of a super-capacitor bank, its voltage and state of charge increases. As the super-capacitor gets discharge, its voltage and SOC both get decreased in a same proportion. Here, the SOC for super-capacitor is getting up to 90%.

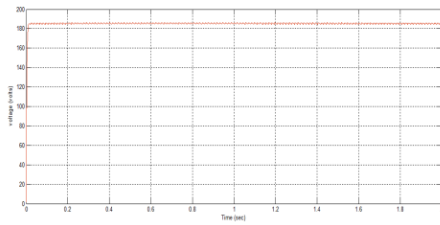

Fig. 6. Buck circuit voltage.

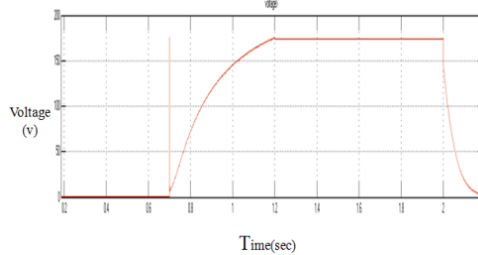

Fig. 7. voltage o a supercapacitor.

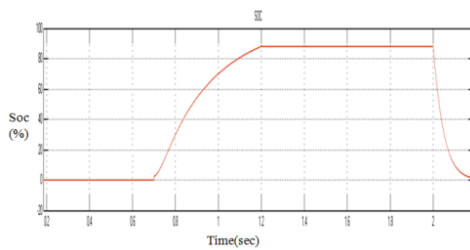

Fig. 8. State of charge of a supercapacitor

IV. HARDWARE SETUP

In this project, the hardware has been implemented by using PWM technique to charge the supercapacitor. A battery with 12V is used for charging the supercapacitor using PWM technique. Control circuit and power circuit has been made as shown in hardware setup. Power circuit consists of a 9-0-9 transformer, heat sinks with two FGA25N120 IGBT, inductor. In this project, the hardware has been implemented by using PWM technique to charge the supercapacitor. A battery with 12V is used for charging the super-capacitor using PWM technique.



Fig. 9. Hardware setup.

Control circuit and power circuit has been made as shown in hardware setup. Power circuit consists of a 9-0-9 transformer, heat sinks with two FGA25N120 IGBT, inductor. Heat sinks are used near IGBT to increase its life and to reduce the temperature by increasing efficiency of the medium. Strip connector is also used. A band switch having three stages of motoring, rest position and braking has been used. A 12-0-12 transformer is used for making a charger. In the project dc motor has been used having specifications of 12V, 10A, 1/20 HP, 5000 rpm. High speed motor is required. From the results taken from hardware, it has been concluded that with the increase in time speed reduces.

Fig.10 shows the motor speed in rpm with braking. From the graph, it can be noticed that during braking operation of motor as brakes apply its speed get decreased with increase of time.

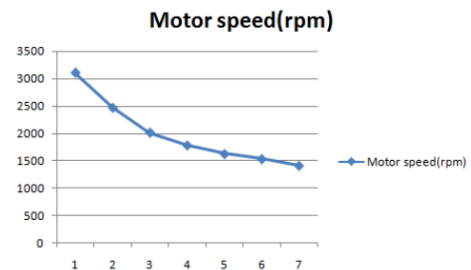

Fig. 10. Speed of motor with regenerative braking.

V. CONCLUSION

From this paper conclusion is made that for the efficient operation of an elevator,

supercapacitor energy storage is the best choice compared with other storages. The results implemented in MATLAB shows that state of charge of supercapacitor is more. So by using the supercapacitor regenerative energy is stored and when required by grid returned back to it. From the graph it is shown that when braking applies to the system speed decreases and as the speed gets reduced means deceleration occurs and energy is saved in the supercapacitor. In this way, energy has been saved by using the proposed technique.

REFERENCES

- [1] A. B. Kulkarni, H. Nguyen, and E. W. Gaudet, "A comparative evaluation of line regenerative and non-regenerative vector controlled drives for ac gearless elevators," in Proc. Ind. Appl. Conf., pp. 1431- 1437, 2000.
- [2] Z. Li, S. Jin-yan, and W. Ning, "High voltage super-capacitors for energy storage devices applications," IEEE Transaction, pp. 1-4, 2008.
- [3] A. Rufer and P. Barrade, "A supercapacitor-based energy storage system for elevators with soft commutated interface," IEEE Trans. Ind. Appl., vol. 38, no. 5, pp. 1151-1159, Sep./Oct. 2002.
- [4] J. He, C Mao, J. Lu, and J. Yang, "Design and implementation of an energy feedback digital device used in elevator," IEEE Trans. Ind. Electron., vol. 58, no. 10, pp. 4636-4642, Oct. 2011.
- [5] Z. Li and Y. Ruan, "A novel energy saving control system for elevator based on supercapacitor bank using fuzzy logic," in Proc. Intern. Conf. ICEM, 2008, pp. 2717-2722.
- [6] M. P. Shreelakshmi and V. Agarwal, "An energy efficient and environment friendly elevator system using ultracapacitor and fuel cell with power factor correction," in Proc. Intern. Conf. ECCE 2013, pp. 721-727
- [7] Z. Li and Y. Ruan, "A novel energy saving control system for elevator based on supercapacitor bank using fuzzy logic," in Proc. Intern. Conf. ICEM, pp. 2717-2722, 2008.