

## **Evaluation of Torsional Strength of Glass Fiber Epoxy composite drive shaft by Experimental Method**

**V. S. Jagadale<sup>1\*</sup>,**

<sup>1\*</sup>Research Scholar, Dept. of Mechanical Engg., Koneru Lakshmaiah Education Foundation, Vaddeswaram (A.P.), 522302, India. Email: vishjagadale@gmail.com

**S. N. Padhi<sup>2</sup>**

<sup>2</sup>Professor, Department of Mechanical Engineering, Koneru Lakshmaiah Education Foundation, Vaddeswaram (A.P.), 522302, India.

### ***Abstract***

Drive shaft plays a significant role in automotive power transmission. The weight of the drive shaft should be optimum to get better outcome. The selection of drive shaft is done based on the designed torsional strength. It means that torsional strength should be same irrespective of the material. In this present work the effort has been taken to evaluate the torsional strength of composite material drive shaft keeping the dimensions unaltered. Here drive shaft is manufactured using wire wound method. The materials chosen are glass fiber and epoxy as a main constituents. The efforts shows the possible replacement of exiting drive shaft with composite one keeping all design parameters as constants.

**Keywords:** Drive Shaft, Wire wound manufacturing, Torsional strength, Glass fiber,

### **1. INTRODUCTION**

The propeller shaft is a pilot shaft that connects the main transmission shaft to the actual axis differential. With universal joints, it transmits the power from the gear box to the rear axle. The shaft is often referred to as the drive tube. A shaft must be designed to meet the stringent automotive design requirements [1]. Results from some researchers clearly show that a single-piece propeller hybrid wave of fiber-reinforced composite and aluminum tubing can be designed with less weight than the steel shaft and a natural frequency above the shaft operating speed [2]. Substitution of standard drive shafts with steel components. AISI 8750 is used as a low alloy tool in this work. The design parameters have been optimized to minimize the drive

shaft's weight. The optimization of the design also showed significant potential improvements in drive shaft performance [3]. Nickel chromium steel SAE3145 has been designed for its suitability in terms of torsional strength, natural bending frequency and torsional buckling [6]. The shafts of the propeller need to be high enough, low sensitivity, heat-treated and wear resistant so that they sustain high bending and wear [7]. Conventional steel propeller shafts are usually made in two parts to increase the natural frequency of the fundamental bending. But three universal joints, an intermediate thrust bearing and a supporting support bracket are part of the two-piece steel driveshaft which increases the total weight of the vehicle [8]. The propeller shaft is the very important part of a vehicle, the vehicle can move forward and reverse through the shaft. This shaft is known as a shaft for a propeller, the overall objective is to design and improve the weight of the light motor vehicle propeller shaft.

## 2. MATERIALS & MANUFACTURING

### 2.1 MATERIALS

On the basis of the values of the mechanical properties obtained from the tensile and shear measures, the best materials with ideal mechanical properties and necessary strength are chosen. A program is made in C++ for selecting the best content. It is suitable for application based on the program output material with a 50/50 volume fraction.

### 2.2 Hand Layup Manufacturing Step



Figure 2.1: Steps used in manufacturing of filament wound product

### 2.3 Mandrill Manufacturing:

Mandrill is produced from the casting process with an outer diameter of 59 mm and a length of 600 mm with taper. Tapper comes with decent surface finish thanks to simple removal of the propeller shaft. Cast iron is the material used for mandrill.



Figure 2.2: mandrill

### 2.4 Manufacturing method:

**Hand- Layup:** The glass fibers and epoxy resins combined with hardener is mounted manually on the surface of the molding, i.e. the mandrill seen in fig.2.2. The glass fiber sheet is then prepared in 45° orientation. Note is taken to make sure that the solvent does not contain air bubbles, because it is used for fiber enhancement. For this purpose, tightened rollers are used to remove air bubbles and to ensure increased fiber wetting.



Figure 2.3: Creating fiberglass drive shaft (a)



**Figure 2.4: Creating fiberglass drive shaft (b)**



**Figure 2.5: Fabricated shaft**

### **3.0 Introduction to Torsion Testing:**

Torsion measures are commonly used to determine the elastic frame, resistance, shear framework, shear strength and other structural properties. The key distinction between the torsion test and the tensile test is that the force over the cross-section of the test specimen is not standardized. Components are often twisted in systems in certain fields of manufacturing activities such as drive shafts, axles and drills. In comparison, structural applications such as beams, coils, car bodies, fuselages for aircraft and boat hulls are arbitrarily bent. The materials used in this case should not only be strong enough but also torque resistant in operation.

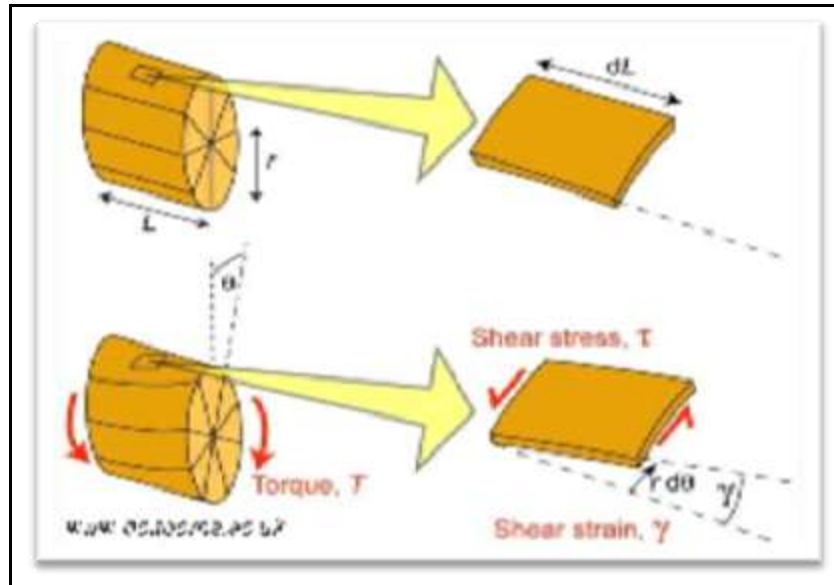

Figure 3.1 Torsion in Cylindrical bar [4]

The torsion test is useful in the processing of delicate products such as machine stain. The method is often used to assess the device forge capability by means of torsion checks at high temperatures.

Table 3.1: Specification of torque testing machine

Sr. No.	Particular	Capacity
1.	Maximum torque.	1500 Nm
2.	Maximum Angle of twist	20 degree
3.	Maximum length of specimen can occupy	250mm
4.	Make of machine	Shreyas Enterprises, Pune
5.	Type of machine	Digital
6.	Input method	Manual

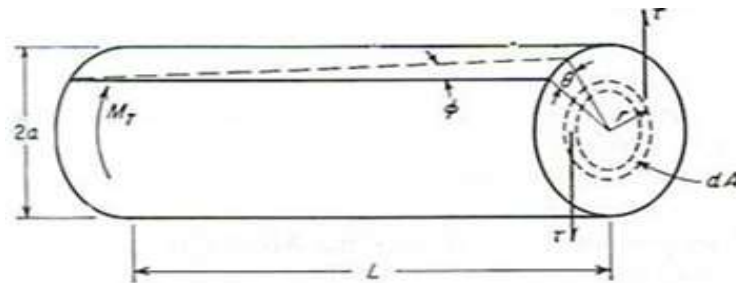

**Figure 3. 2 Shaft Mounting machine**

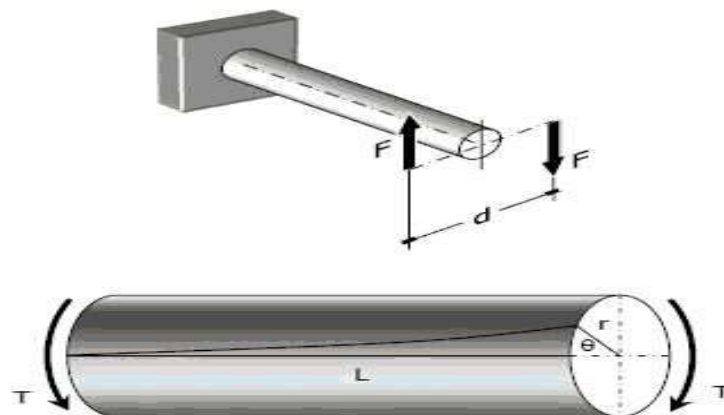

**Figure 3.3 Torsion testing machine**

As shown in Figure 3.2, the twist test is conducted with the torque test by placing the specimen in the torsion testing system and then using the twisting moment before failure. Torque and rotational frequency are calculated and mapped as shown in the diagram. Higher torsional force is necessary in higher rotational degrees. The research specimens used are usually cylindrical, since the stress distribution through the rod segment is the easiest structure that is easy to quantify stresses.



**Figure 3.4 Torsion of bar [6]**



**Figure 3.5 Torsion Twisting of Bar [6]**

**Experimental Procedure:**

The first thing that was done in the lab was the measuring of the diameter of the specimen gauge section using calipers, and to record that value for later calculations. After that, it was necessary to draw a straight longitudinal line on the specimen so that the angle of twist of the specimen can be observed during the test.

**4. RESULT & DISCUSION**

A 250 mm long specimen was used to measure the torque capabilities of the composite drive shaft, which had been shortened to be mounted on the torque tester. Fig. Fig. 4.1 The angle diagram for torque distortions of the shaft shows up to 676.9 N-m at maximum torque.

The torsion test is carried out **at Shreyas Enterprises, Warje-Malwadi, Pune**. In the torsion test we get the results as follows:

**Table 4.1:- Torque applied and angle of Twist**

Sr. No.	Applied Torque (N-m)	Angle of twist (Degrees)
1	56.9	0.5
2	101.0	1.0
3	143.2	1.5
4	168.7	2.0
5	191.3	2.5
6	209.9	3.0
7	228.6	3.6
8	246.2	4.0
9	312.0	6.0
10	375.7	8.0
11	418.9	10.0
12	485.6	12.0
13	540.5	14.1
14	585.7	16.1
15	637.7	18
16	676.9	20

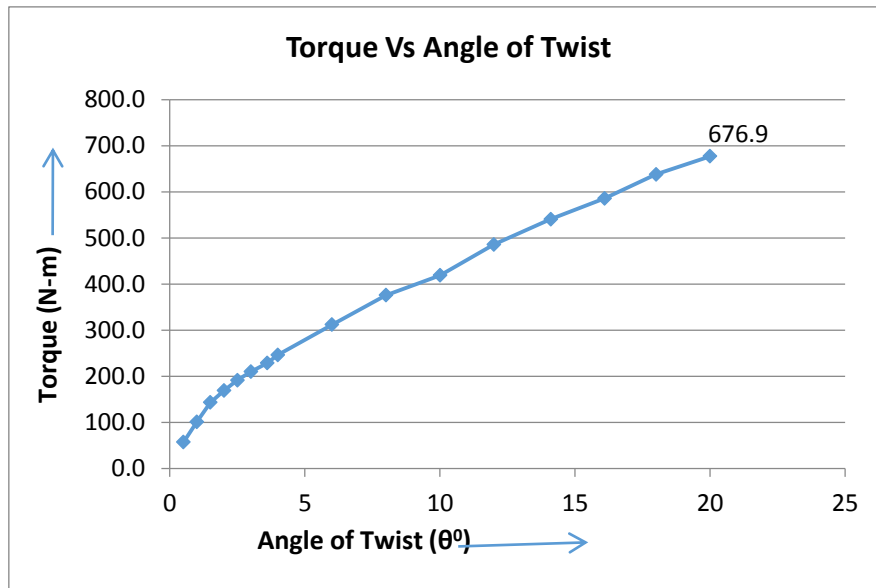

Fig. 4.1 Torque vs. Angle of Twist graph obtained from torsion testing

## 5. CONCLUSION

A one-piece composite material driven shaft was optimally constructed to minimize the weight of the shaft, which was under restrictions, such as normal bending frequency, with the application of classical lamination theory. The composite material for the production of the drive shaft can be used for the same design parameters for the steel shaft.

## REFERENCES

- [1] V. Jose Ananth Vino, Dr. J. Hameed Hussain, "Design and Analysis of Propeller Shaft", International Journal of Innovative Research in Science, Engineering and Technology, Vol. 4, Issue 8, August 2015
- [2] H. B. H. Gubran and K. Gupta, "Design Optimization of Automotive Propeller Shafts", Journal of Vibration Engineering & Technologies, Vol. 2, No. 1, February 2014.
- [3] R. Harimaheswaran, N. Jeyakumar, R. Satheeshkumar, P. Viswabharathy, "Design Optimization and Analysis of Propeller Shaft", International Journal of Emerging Technologies in Engineering Research (IJETER), Volume 5, Issue 4, April 2017.



*Research paper*

© 2012 IJFANS. All Rights Reserved, UGC CARE Listed (Group -I) Journal Volume 8, Issue 2, 2019

- [4] Srinivasa Rao A, Ch.Lakshmi Poornima, K.Sunil Ratna Kumar, B.V Subrahmanyam, “Propeller Shaft Design and Analysis by using Composite Material”, International Journal of Scientific Research and Review, Volume 7, Issue 1, 2018.
- [5] Nizam S Sakeer, Thoufeek A, Vyshak O R, Hallaj J, Mathews Thariyan, “Design, Analysis & Optimization of propeller shaft with composite materials by using software’s”, International Research Journal of Engineering and Technology (IRJET), Volume 06, Issue 05, May 2019.
- [6] Sweety P. Mhaske, Nitin P. Doshi, “Failure Analysis and Design Modification of Propeller Shaft of Bus”, International Journal for Research in Applied Science & Engineering Technology (IJRASET), Volume 4 Issue X, October 2016.
- [7] Atul Kumar Raikwar, Prabhash Jain & Rajkumari Raikwar, “Design and optimization of automobile propeller shaft with composite materials using FEM Analysis”, International Journal of Engineering Development and Research, Volume 4, Issue 4. 2016.
- [8] Swapnil Shinde, “Design and Optimization of Propeller Shaft Made Up of Composite Material”, International Engineering Research Journal, Page No 1046-1053.
- [9] Sandip R Mali, S.S. Patil, “Review Paper on Design and Optimization Of Composite Propeller Shaft For Light Motor Vehicle”, International Journal of Engineering Research & Technology (IJERT), Vol. 7 Issue 07, July-2018.