

GSM BASED ENERGY METER BILLING WITH LOAD CONTROL

¹Chedde Balakrishna,²Mala Naveen Kumar,³Kosigi Thayanna,⁴Uppara Mahesh Kumar,⁵Ediga Aravind Kumar,⁶Pavithra V M,⁷Dr. K. Chithambaraiah Setty

Department of EEE, St. Johns college of Engineering and Technology, Yemmiganur, AP

ABSTRACT:

Currently, the energy meter is installed in residential or business locations to gather information on the amount of energy used, which is then shown on either a traditional dial or a digital screen. At the conclusion of each billing cycle, a representative from the service provider must physically visit the location where the meter is installed in order to get the reading and record it for the purpose of generating the subsequent bill. The current energy billing system is both flawed and time-consuming. The objective of this project is to create an energy meter that can measure the amount of power utilized by the user in kilowatt-hours (kWh). Additionally, it will provide real-time monitoring of consumption, eliminating the need for meter readers to visit each customer to collect data and deliver bill slips. The energy consumption is determined by measuring the voltage and current. In addition, it consistently monitors the energy meter readings and autonomously transmits notifications such as low-balance alert, zero-balance alert, and recharging alert to the registered phone via a GSM modem. Anomalies in the use of electricity have been noticed and an alarm message is promptly sent to the authorities. The Arduino code does power and energy calculations, and sends a message to the respective customer indicating their unit use and the amount of their bill.

Key terms: GSM, Energy Meter, Load Control, Arduino Project, Smart Billing System.

1. INTRODUCTION

Research and development of intelligent electrical energy meter technologies have been conducted for almost a decade. Several technologies have been created and used for the purpose of measuring electricity usage. Users will get the billing statement from the energy board when they have produced and submitted it using various means. Currently, the majority of houses in Malaysia, such as, employ classic electro-mechanical watt meters, which lack automated reading capabilities. Users must wait for the monthly energy usage bill in order to pay their energy bill. Typically, at the conclusion of each month, a representative from the meter board billing department will visit each residence to record the meter reading and simultaneously provide the charge to the occupants. An electricity meter, also known as an energy meter, is a device used to quantify the quantity of electric energy utilized by a house or company. There are two categories of meters for Domestic Ordinary Power Consumers: single phase and three phase. The energy consumption is quantified by all electrical services via the use of a kilowatt-hour meter, which measures the amount of energy consumed in kilowatt-hours (kWh). Electronic meters were subsequently produced as a replacement for electro-mechanical meters, offering a similar function but using a digital system instead of an analog one. This system allows users to record the voltage, power reading unit, current, and the time and date of energy use. This approach has many benefits compared to the

conventional method of meter reading. Following the introduction of electronic meters, meter reading has evolved to include Bluetooth technology, a wireless communication method commonly referred to as Automatic Meter Reading (AMR). This device is equipped with wireless capabilities, allowing the user to use a personal computer to accurately monitor and record the power usage of an energy meter. The reading meter data will be stored in the database and a bill will be created. The most recent technology use a system based on Global System for Mobile Communication (GSM). This solution supplants the use of Bluetooth technology and Short Message Service (SMS) for transmitting data to both the consumer and the energy board.

II. OBJECTIVES

1. The user may get the current status of available units.
2. If the user's daily usage exceeds the limit, they will get a warning message.
3. Enable user-controlled load management via SMS.
4. The user may get the daily energy usage in units for the purpose of energy conservation.
5. The user will get the bill by text message.

III. PROJECT METHODOLOGY

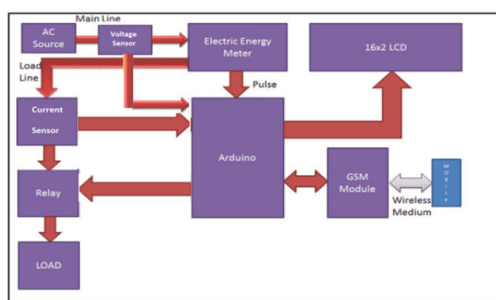

Fig.1 Block diagram of GSM based energy meter

The microcontroller in this project is powered by a 5V supply from a voltage regulator that ensures a stable voltage of 5V. The microcontroller is linked to a 16*2 LCD display using four data pins, namely D4, D5, D6, and D7. These pins are attached to digital pins 9, 8, 7, and 6 of the microcontroller, respectively. Additionally, the E and RS connections of the LCD display are connected to digital pins 10 and 11 of the microcontroller, respectively. The 16*2 LCD display is supplied with a voltage of 5V via the VDD pin, while the VSS pin is linked to the common ground of the circuit. To ensure the appropriate brightness of the LCD display, the VEE is linked to a common ground via a 1K resistor. The R/W signal is maintained at a low level during write operations. The 16*2 LCD display is used to monitor parameters such as voltage, current, power, and unit balance. A GSM SIM800L module has been used for wireless SMS notification and data dissemination. An Arduino microcontroller is linked to a GSM module via serial communication ports. The Arduino microcontroller is equipped with hardware serial ports that are designated on digital pins 0 and 1. However, it is possible to use a software serial library in Arduino code to designate any of the 14 digital pins as serial pins (Rx, Tx) for the purpose of serial communication. The Rx and Tx pins of the GSM module are linked to digital pin 2 and 3 of the microcontroller, correspondingly. The ACS712 current sensor is used to measure the current of the load that is being drawn from the distribution

transformer. The project currently utilizes a sensor with a rating of 30A. The current sensor is equipped with three pins, namely VCC, GND, and Output. The current produces an analog voltage output that ranges from 0 to 5V. The output of the current is linked to the analog A4 pin of the atmega328P integrated circuit (IC) on the Arduino board. A circuit is constructed to measure the voltage of an AC power source. The circuit converts the AC voltage into a DC form, which can be detected by an Arduino microcontroller. To do this, a step-down transformer with a rating of 240/9V is used to decrease the voltage within the range of 9-10V. The transformed voltage is then linked to a bridge rectifier. The Arduino microcontroller has a maximum limit of 5V for reading analog voltages. Therefore, a resistor divider circuit is used to get a voltage value that is lower than 5V. A 5V direct current (DC) relay switch is used to regulate the power supply to the load using a microcontroller. Typically, the relay switch is configured to be in the normally closed (NC) state when a LOW signal is sent to it from the microcontroller. Whenever the relay receives a HIGH signal from the microcontroller, it transitions to the normally open (NO) state. A simple energy meter with a pulse rate of 3200 impulses per kilowatt-hour has been used for the purpose of project demonstration. The microcontroller receives the output of the calibration LED of the meter using a 4n35 optocoupler. The opto-isolator serves to separate the low voltage side, namely the microcontroller end, from the high voltage AC side. The AC-DC bridge rectifier circuit provides power to the complete microcontroller and other auxiliary circuit. A transformer with a voltage ratio of 230/9V and a current rating of 750mA is used. The output of this transformer is connected to a diode bridge rectifier circuit to convert the alternating current (AC) voltage into direct current (DC). Additionally, a 10 μ F capacitor is utilized as a filter. The output of this circuit is a direct current (DC) voltage of 9 volts. To ensure a constant 5 volts of DC power is supplied to the whole circuit, a 7805-voltage regulator integrated circuit (IC) is used. When the power supply is activated in this project, the Arduino microcontroller begins running the program code. This code initializes all the sensors and devices that are attached to the Arduino microcontroller. The software code first initializes the LCD display and then proceeds to configure the GSM module by setting the baud rate to 9600. The microcontroller retrieves the state of all pins during the execution of the void setup loop. Initially, the LCD display shows the project's name. Additionally, it enables the GSM module to stay in a state of readiness for the purpose of transmitting and receiving real-time SMS messages. According to the program code, the default value of the unit balance in the energy meter is set to '4' units, which is equal to 40Rs. This is because the tariff has been set at 10Rs per unit. The microcontroller constantly monitors the energy use of home appliances and updates the unit balance. This information may be utilized to send alarm messages to mobile phones. The voltage sensor is created using a voltage divider circuit. It consists of two resistors, one with a value of 100 Ω and the other with a value of 220 Ω , linked in series. A 9V DC input is applied to this circuit. The voltage drop across the 100 Ω resistor in the voltage divider circuit during the outage is about 2.9 V. The microcontroller is attached to the analog pin A3. To measure the voltage of a power source, a factor of 80 must be used to get the actual voltage on the AC side.

IV. WORKING OPERATION

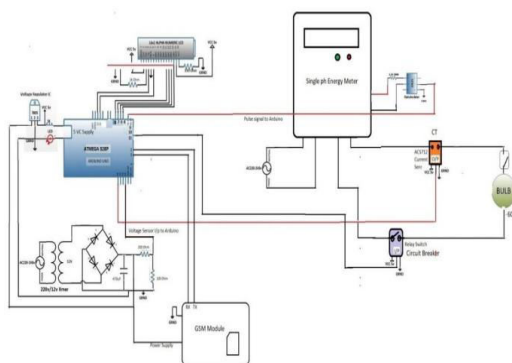

Fig.2 Circuit diagram of GSM based energy meter

The voltage value, measured in volts, is saved in a floating-point variable named 'voltage'. It is continually shown on an LCD screen for monitoring purposes. Additionally, the microcontroller utilizes the voltage value stored in the variable for calculating power and energy usage. The ACS712 current sensor is linked to the microcontroller's analog A4 pin and provides a millivolt output that corresponds to the current passing through the load. A conversion factor of 66 should be used to determine the actual amount of current flowing in the circuit. The Atmega328p microcontroller has a 10-bit integrated analog-to-digital converter (ADC) that translates analog signals ranging from 0 to 5 volts into a digital representation within the range of 0 to 1024. The current value, measured in amperes, is saved in a floating-point variable named 'current'. It is continually shown on an LCD screen for monitoring purposes. Additionally, the microcontroller utilizes this current value stored in the variable for calculating power and energy consumption. The Arduino microcontroller sends an AT instruction to the attached GSM module to initiate the connection. The received AT instructions enable the GSM modem to be configured for both sending and receiving SMS messages. The microprocessor computes the power and energy consumption by using data from current and voltage sensors. It then determines the unit balance in the energy meter, which is initially set to a default value of '4'. Once the unit balance drops below 4 units, the microcontroller instructs the GSM modem to send an SMS alert to the mobile phone, prompting the user to recharge their account using any of the specified recharging options. If the consumer does not recharge their account after receiving an alert SMS, and the unit balance in the energy meter drops below 2 units, the microcontroller will send a HIGH signal to the relay in order to disconnect the power supply to the household loads. Additionally, an SMS will be sent to the consumer's mobile phone, informing them that the power supply has been disconnected due to low balance. Previously, we initiated a recharge by sending a text SMS with the content 'Recharge_100' to the GSM modem. The modem then sent the SMS to the microcontroller, which processed the message and executed the appropriate actions based on the code. Therefore, the microcontroller transmits a LOW signal to the relay in order to restore the power supply. Additionally, the microcontroller sends a confirmation SMS to the mobile phone via the GSM module to acknowledge the recharge. The consumer is able to access the current unit balance and the current load linked to the energy meter. To get this information, the consumer must send a command called 'Get_Status' to the GSM modem of the energy meter. The microcontroller then receives this command over the serial port and

sends a response SMS to the GSM modem, providing the current unit balance and the load amount in megawatts. This intelligent energy meter is equipped with a feature that allows for remote control of domestic power supply via a GSM modem. In order to deactivate the primary power supply of a residence, the consumer must send an SMS with the content 'Supply_OFF' to the GSM modem. Subsequently, the customer will get a confirmation SMS from the energy meter indicating the status of the power supply deactivation. In order to activate the power supply, the consumer must send an SMS with the message 'Supply_ON' to the GSM modem of the energy meter. The customer will then get a confirmation SMS indicating that the power supply has been successfully turned on.

V. RESULTS & DISCUSSION

The outcome is achieved by receiving energy billing information by phone via text message. Load management is managed using SMS. An alarm message is sent when the predetermined unit consumption value is surpassed. All parameter values, such as remaining units and power consumption, are shown.

OBSERVATION TABLE :

Sr.no	Condition	Command	Message Received
1.	When the daily limit is crossed	-	Dear customer, Alert! Low balance in your energy meter having consumer no. 12341234. Please recharge to avoid disconnection of power supply, Thank you .
2.	When the supply is disconnected	-	Dear Customer, power supply has been disconnected of consumer no.12341234. Please recharge to resume the connection. 20.00Rs/- bill amount for your energy meter.
3.	When user wants to recharge	Recharge_100	Dear Customer, Recharge of Rs100 is successful on your energy meter . The power supply has been resumed.
4.	When user wants to check the status	Get_Status	Dear Customer, 7.64 units balance remained in your energy meter.
5.	When user want to Turn On the load.	Supply_ON	Dear Customer , power supply has been resumed by consumer no.12341234, Thank You.
6.	When user want to Turn Off the load.	Supply_OFF	Dear Customer ,power supply has been disconnected by consumer no.12341234, Thank You

RECHARGE COMMANDS TABLE :

Sr.no	Command	No. of units recharged
1	Recharge 50	5 unit
2	Recharge 100	10unit

VI. CONCLUSION

The deployment of the GSM based energy meter billing with load control effectively achieves all suggested goals and obtains all desired outcomes. The suggested approach will significantly increase people's awareness of their energy use and aid in the preservation of traditional resources that are rapidly diminishing.

REFERENCES

- [1] Mr. Ankush S. Gutte, Dr. H.K. Naidu “Power Meter Billing Plus Load Control Using GSM”, International Journal for Research in Applied Science & Engineering Technology (IJRASET) , page no 210-212, august 2017.
- [2] Ashna.K and Sudhish N George, "GSM based automatic energy meter reading system" IEEE 2013.
- [3] Vivek Kumar Sehgal,Nitish Panda, Nipun Rai Handa, “Electronic Energy Meter with instant billing”,UKSim Fourth European Modelling Symposium on Computer Modelling and Simulation . pg no .237-241, Nov 2012.
- [4] A. Abdollahi, M. Dehghani, and N. Zamanzadeh , “SMS based reconfigurable automatic meter reading system,” IEEE International Conference on Control Applications (CCA 2007),Oct, 2007, pp. 1103 - 1107.
- [5] Vanishree k Rao, Sri G N Madhu , “GSM based energy meter billing and reading” , IJSR 2016 .
- [6] “A Novel Approach For Smart Energy Meter Using 89C51 Microcontroller”, Ms.Shraddha M.Bang Ms. Anushree A. Wankhade, Suyog B.Pavitrakar ,Sangram S. Deshmukh, Prof. Manish K.Shriwas, IJSER,2016.
- [7] “Design of GSM Based Smart Automatic Energy Metering System”, Kiran Mahale , Shraddha Bansal, IJETAE, March 2015.