

# Power Management Scheme for DC Microgrid Distributed Generators: A Novel Approach

T Vijay Muni

Department of Electrical and Electronics Engineering, Koneru Lakshmaiah Education Foundation, Vaddeswaram, Andhra Pradesh, India.

Mail id: vijaymuni1986@gmail.com

**Abstract.** A preferred method for integrating numerous renewable energy sources into the network and running them concurrently is the energy management system. Controlling the energy dispersed across various distributed generators is crucial for the stable operation of the power system. The power of each individual generator in the specific DC network is controlled in this thesis work using a novel way based on the fall control technique. To achieve high energy distribution efficiency and also to increase stability, the suggested energy management system can be widely implemented to both the grid connected to the grid and the grid separated from the electricity grid Based on the drop control principle, an effective power control mechanism is created for dividing the power needed by the load. A single distributed generator can use the suggested controller to regulate its output power quickly and precisely. By modelling transient stability and steady state test tests, the power sharing control approach was developed, modelled, and validated. Additionally, the ideal coupling resistance for power sharing was found. Investigations into controller interface and communication lag were also conducted. The shared power controller experiences very little interference from communication delay. The MATLAB/SIMULINK environment is used to model the system.

**Keywords:** DC micro grid, grid, power management, simulation, droop control.

## Introduction

Now-a-days, the use of renewable energy has increased due to environmental concerns and the increased price of fossil fuels [1]. Continuous development in industrial and commercial sectors has become a burden to the traditional power grid and hence the demand for renewable resources [2] integrated grid systems has increased [3]. Traditionally, alternating current is being used due to its ability of stepping up and stepping down of the voltage based on the needs at the load end [4]. Recently in the field of electric power generation, transmission and distribution, the use of DC power has drastically

increased [5]. The aim of the thesis is to integrate the DC power network with the AC power network and not the replacement of AC with DC [6].

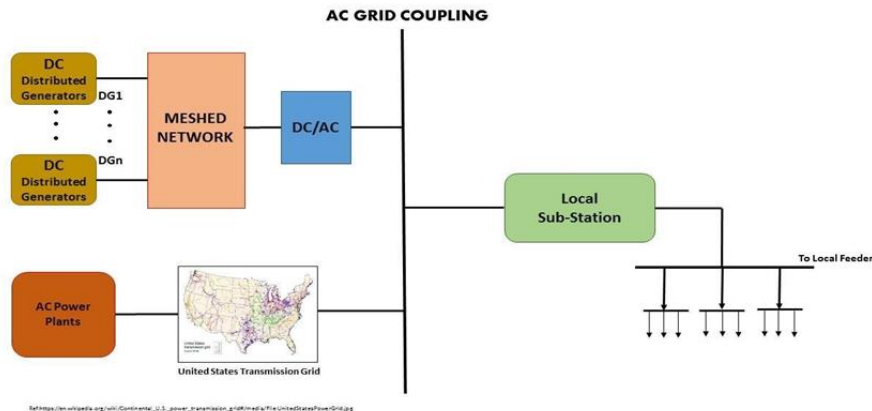

Figure 1. Integration of DC and AC Power Network

Fig.1 shows the integration of the DC and the AC network, where the DC distributed generators and the AC generating systems are connected to the same grid network[7]. The DC distributed generators require a DC-AC converter system to be integrated with the AC grid [8]. When there is broader access to electricity, the efficiency of the transmission grid is found to be more balanced. When the demand increases, the generating capacity finds it difficult to meet the required demand [9]. This could be rectified by installing microgrids with renewable energy sources as the primary source of electric power [10]. Here, multiple generators are connected to a single microgrid to meet the demand at the load end of the microgrid. The microgrid also has access to be integrated with the traditional grid network. The integration of the distribution system enhances energy management, conversion efficiency and grid reliability [11].

The proposed power management scheme for distributed generators in DC networks has several advantages including improved efficiency and optimized synchronization over the previous converters[12]. The system designed in the work can fit commercial renewable power networks. The working efficiency of the system is maintained by providing proper power sharing between the distributed generators connected to the DC system [13]. Droop control is used as the principle to design the controller in each converter. The stability analysis is performed for the system designed. Testing of the model is performed using the MATLAB/SIMULINK software [14].

## 1. Concept of DC Microgrid

Microgrids can operate autonomously or can be grid connected and based on the type of power; it can be AC or DC. Tremendous advancement in the field of DC energy [15] has led to the introduction of DC microgrids in the power network. The DC microgrids have better efficiency and compliance with the customer electronic loads as well [16]

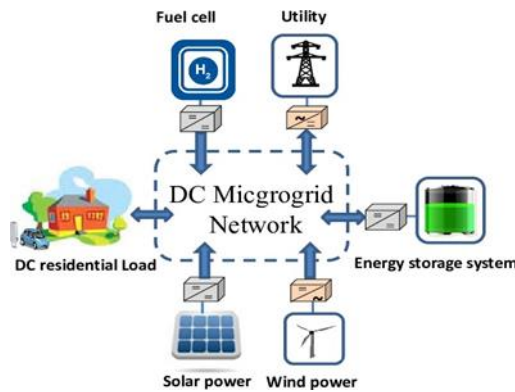

Figure 2. DC Microgrid network

The DC distribution enhances the incorporation of renewable[17] energy sources as it eliminates conversion and saves 2.5% to 10% of the generated energy.

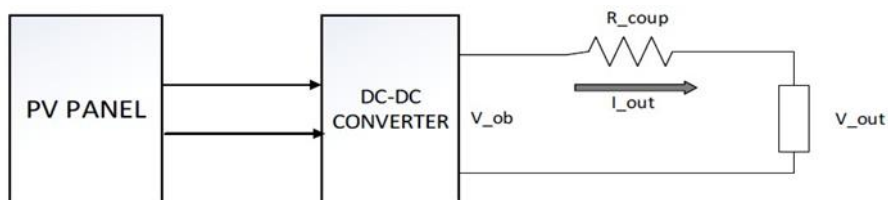

Figure 3. Block Diagram of Proposed Model

The entire model is designed based on the fact to maintain the voltage drop to less than 4%. Fig. 4 represents the droop curve of the proposed model [18]. The x-axis represents the output power or the load power of the system. This indirectly represents the load current or the output current as the voltage across the entire system is maintained constant throughout [19]. The y-axis represents the output voltage of the converter. Two points  $P1$  and  $P2$  are marked on the graph. When there is no output current, the system is designed to maintain a 4% higher droop in voltage and when the system is at rated power, the voltage is also at rated condition [20]. The output voltage at the converter end is dependent on the droop value [21]. From the droop curve, as the output power of the system changes from 0 to the rated value, the output voltage of the converter changes from  $m \cdot V_{ob}$  to  $V_{ob}$ .

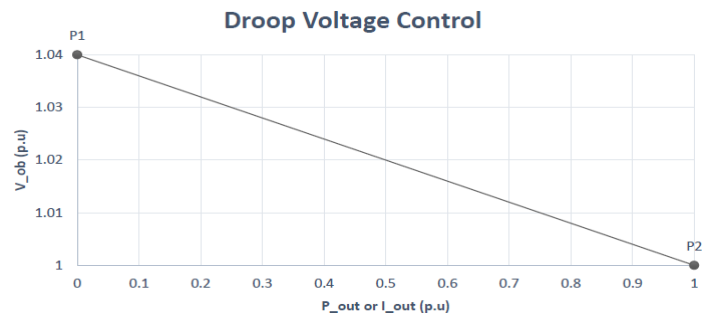

Figure 4. Droop Curve

## 2 Modelling & Simulation Results

*Case (i) Single unit DG:* Simulation has been performed using the MATLAB/SIMULINK software. Fig.5 shows the Simulink model of single unit distributed generator. The input source is the PV source, and the output voltage source represents the grid connection to the converter. The coupling resistor acts as the interface between the converter and the grid system. The value of inductors and capacitors connected in the system are calculated using the duty cycle calculation. The measured values of voltage and the current output is given to the droop controller block for the generation of the required converter output voltage signal. This signal is in turn given to the duty cycle generator for the duty cycle signal generation, which is given as the switching signal to the connected MOSFET switch in the DC-DC converter.

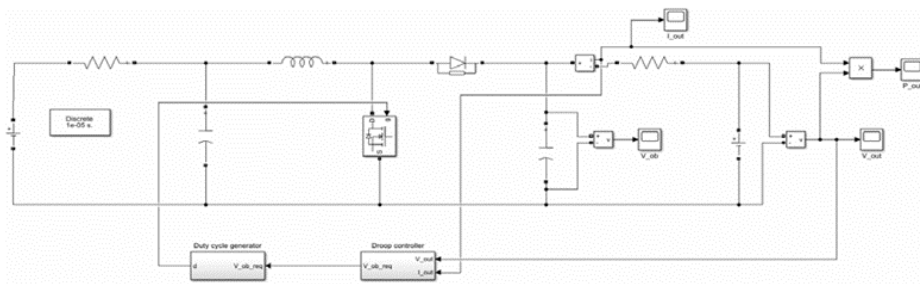

Figure 5. Simulink Model of Single Unit Distributed Generator

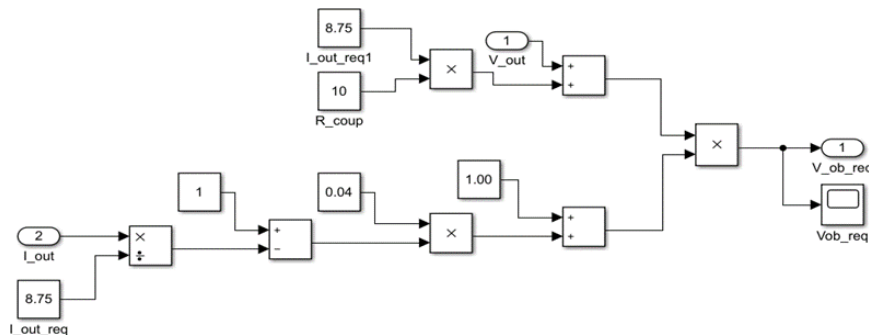

Figure 6. Simulink Model of the Droop Controller Block

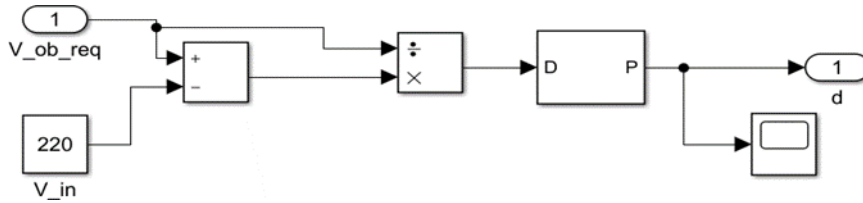
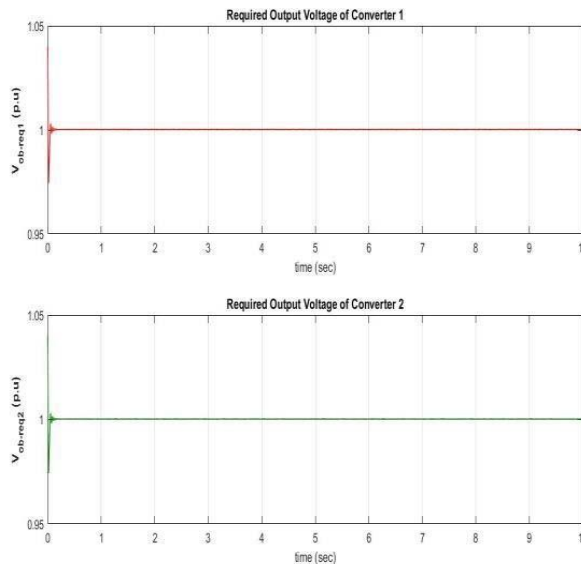

Figure 7. Simulink Model of the Duty Cycle Generator Block

**2.1 Two single unit DG’s operating in parallel:**

Two single unit systems are connected in parallel to the load and the grid system. All the values are similar to the single unit systems except for the grid and the load values. The parallel units-based system is designed to meet the power sharing requirements (Fig. 10). The load power or the power demand is equally divided among the distributed generators based on the working conditions of the generators. The power is contributed equally by the generators when they are operating in full load conditions. When any of the generator experience maintenance or technical interruptions, it would only be able to generate load lower than the full load capacity. During this condition, the converter at full load generates the rated power and the remaining power demand is met by the other converter and the grid. As one of the converters’ capacity decreases, the input power from the grid increases to meet the power demand.



Research paper

© 2012 IJFANS. All Rights Reserved, UGC CARE Listed ( Group -I) Journal Volume 10, Iss 4, 2021

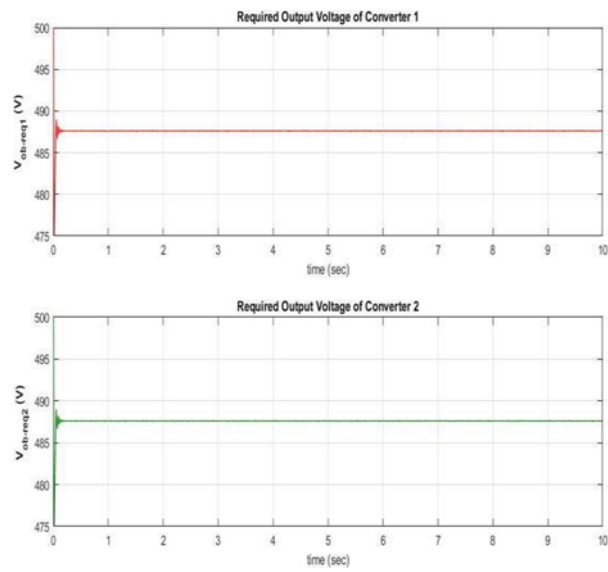
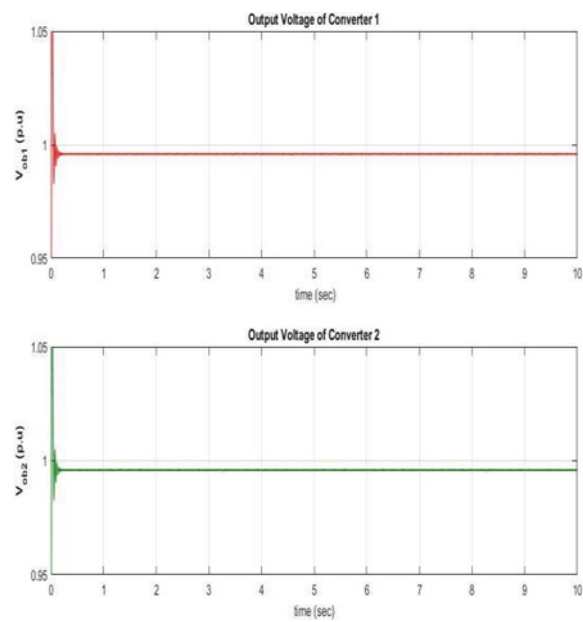

Figure 10 Required Output Voltage Waveform of Converters



Research paper

© 2012 IJFANS. All Rights Reserved, UGC CARE Listed ( Group -I) Journal Volume 10, Iss 4, 2021

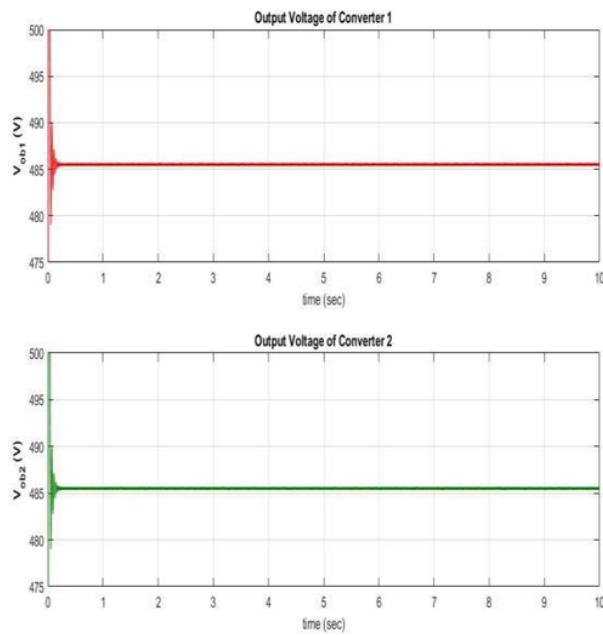
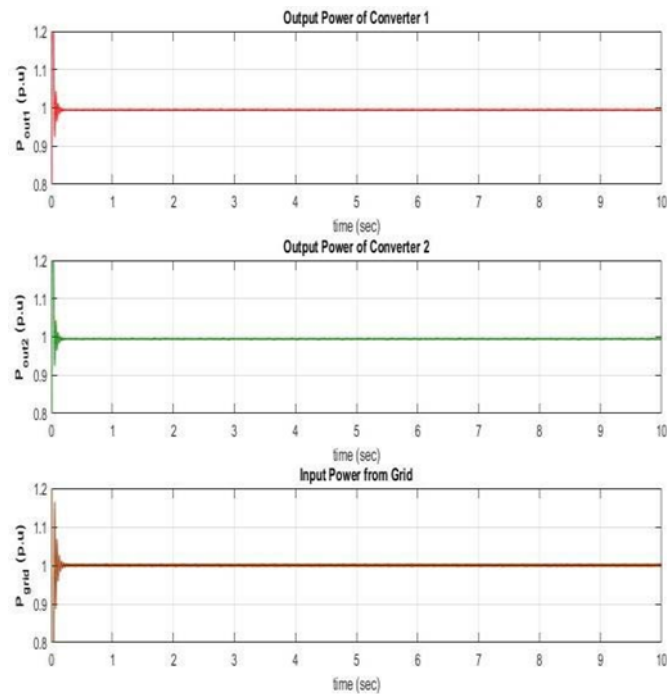

Figure 11. Measured Output Voltage Waveform of Converters



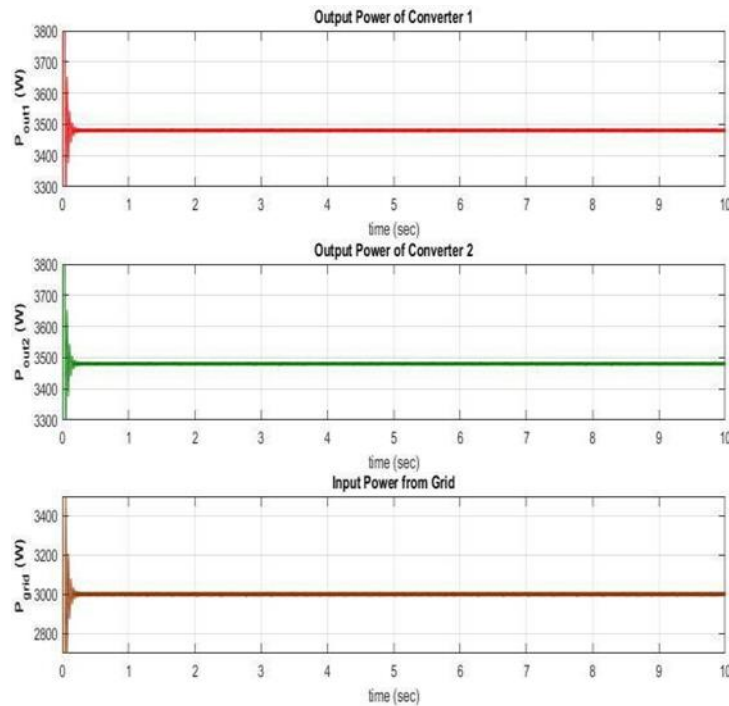

Figure 12. Measured Power Waveforms of the Model

Fig.11 represents the measured output voltage of the converter. The system shows only a drop of 2.11V between the required output voltage and the measured output voltage of the converter. The power sharing between the converters is entirely controlled by the droop controllers of the converters. This indicates that the calculated output voltage of converter is the key factor for the power control between the distributed generators. The base value of output voltage of the converters are taken as 487.5V to meet the voltage drop across the coupling resistance of  $10\Omega$ . The power output waveforms are represented in Fig.12. The base value of the output power of each converter is taken as 3.5kW and the base value of the input power from the grid is taken as 3.0kW. The parallel converters exhibit equal power sharing among the converters. The converters operate at a full load condition delivering a power output of 3.5kW each. The load connected to the system is 10kW. And hence the remaining power is given to the system by the grid which is about 3.0kW. Even if there is an interruption in any of the converter system, the other converter shares the power efficiently and the remaining power is contributed by the grid. The performance of the system is analyzed by measuring the output current and power of each of the converters. The output current and power contribution of each of the converters connected to the load are equally shared and the system stability is maintained.

## Conclusion



It is carried out and analyzed how the dispersed generators attached to a DC microgrid system share electricity. By doing a steady state and dynamic analysis of the system, the operation of the system is tracked. The experiments are run for different coupling resistance levels. This leads to the conclusion that when the coupling resistance value is kept above 0.3p.u, the system performance and efficiency are unaffected, and the system is also optimized. With the aid of the droop controllers built into each converter, the system can operate at its 400V rated system voltage. Because the voltage is kept constant, Controlling the output current of each converter makes it simple to manage electricity. Each converter receives an external and internal communication signal that the system uses to maintain stability within the available range. This aids in reducing the impact of instability and the likelihood of blackouts. Theoretically, any DC generators may use this cutting-edge power sharing control to regulate their output power.

### References

1. T. Dragičević, X. Lu, J. C. Vasquez, and J. M. Guerrero, "DC microgrids—Part I: A review of control strategies and stabilization techniques," *IEEE Transactions on power electronics*, vol. 31, no. 7, pp. 4876-4891, 2016.
2. T. Dragičević, X. Lu, J. C. Vasquez, and J. M. Guerrero, "DC microgrids—Part II: A review of power architectures, applications, and standardization issues," *IEEE transactions on power electronics*, vol. 31, no. 5, pp. 3528-3549, 2016.
3. Pratt, P. Kumar, and T. V. Aldridge, "Evaluation of 400V DC distribution in telco and data centers to improve energy efficiency," in *Telecommunications Energy Conference, 2007. INTELEC 2007. 29th International*, 2007, pp. 32-39: IEEE.
4. D. J. Hammerstrom, "AC versus DC distribution systems did we get it right?" in *Power Engineering Society General Meeting, 2007. IEEE*, 2007, pp. 1-5: IEEE. D. Thukaram, L. Jenkins, and K. Visakha, "Optimum allocation of reactive power for voltage stability improvement in AC-DC power systems," *IEE Proceedings-Generation, Transmission and Distribution*, vol. 153, no. 2, pp. 237-246, 2006.
5. U. Nutkani, P. C. Loh, and F. Blaabjerg, "Cost-based droop scheme with lower generation costs for microgrids," *IET Power Electronics*, vol. 7, no. 5, pp. 1171-1180, 2014.
6. T. Irving and M. M. Jovanovic, "Analysis, design, and performance evaluation of droop current-sharing method," in *Applied Power Electronics Conference and Exposition, 2000. APEC 2000. Fifteenth Annual IEEE*, 2000, vol. 1, pp. 235-241: IEEE.

7. J. Schonbergerschonberger, R. Duke, and S. D. Round, "DC-bus signaling: A distributed control strategy for a hybrid renewable nanogrid," *IEEE Transactions on industrialelectronics*, vol. 53, no. 5, pp. 1453-1460, 2006.
8. K. De Brabandere, B. Bolsens, J. Van den Keybus, A. Woyte, J. Driesen, and R. Belmans, "A voltage and frequency droop control method for parallel inverters," *IEEE Transactions on power electronics*, vol. 22, no. 4, pp. 1107-1115, 2007.
9. Baig, K., Prudhvi Raj, K., Raja Sekhar, G. G., Vijay Muni, T., & Kiran Kumar, M. (2020). Power quality enhancement with active power control. *Journal of Critical Reviews*, 7(9), 739–741. <https://doi.org/10.31838/jcr.07.09.143>
10. Bhargavi, R., Ganesh, P., Raja Sekhar, G. G., Prakash, R. B. R., & Muni, T. V. (2020). Design and implementation of novel multilevel inverter. *Journal of Advanced Research in Dynamical and Control Systems*, 12(2), 1322–1328. <https://doi.org/10.5373/JARDCS/V12I2/S20201169>
11. Muni, T. V., & Lalitha, S. V. N. L. (2020). Implementation of control strategies for optimum utilization of solar photovoltaic systems with energy storage systems. *International Journal of Renewable Energy Research*, 10(2), 716–726.
12. Muni, T. V., Varma, P. S., Priya, S. K., Bhavya, J., & Rajasekhar, S. (2020). Energy management in a DC microgrid with energy storage system. *Journal of Advanced Research in Dynamical and Control Systems*, 12(2), 130–136. <https://doi.org/10.5373/JARDCS/V12I2/S202010015>
13. P. Jyothi, R. B. R. Prakash, P. Srinivasa Varma, Application of Artificial Intelligence to DFIG based Wind Farm for Reactive Power Compensation, *International Journal Of Renewable Energy Research*, Vol.10, No.2, June, 2020, PP-955-966.
14. J Rajesh Reddy, A Pandian, R Dhanasekaran, Rami Reddy Ch, B Prasanna Lakshmi, B Neelima Devi (2020), "Islanding detection of integrated distributed generation with advanced controller", *Indonesian Journal of Electrical Engineering and Computer Science*, Volume 17, issue no 3, pp. 1626-1631, March 2020, ISSN Number: 2502-4752
15. [M Nikhitha, S Abhishek Kumar, J Sai Srividya, P Sravya, Vinay Are, R B R Prakash, "Mitigation Of Current Harmonics In Wind Power Plant Using Fuzzy Based Shunt APF Controller", *Journal of Critical Reviews*, Vol 7, Issue 1, 2020.
16. Rajesh Reddy, J., Pandian, A.(2019), "Improved ROCOF relay for islanding detection of solar distributed generation", *Indonesian Journal of Electrical Engineering and Computer Science*, Volume 14, issue no 3, pp. 1105-1113, June 2019, ISSN Number: 2502-4752
17. Volume 14, issue no 3, pp. 1105-1113, June 2019, ISSN Number: 2502-4752
18. Krishna Reddy B, D Seshi Reddy, J Somlal, R B R Prakash, "A Novel Control Strategy to manage the Power in hybrid Micro grids", *Journal of Advanced Research in Dynamical and Control Systems* (2020) Vol 12, No 2, pp 1343-1354. 10.5373/JARDCS/V12I2/S20201172

19. Mounika Muppavarapu, G G Rajasekhar, T Vijay Muni, R B R Prakash, “Enhancement of Power Quality In A Grid Connected UDE Based PV Inverter”, Journal of Critical Reviews, Vol 7, No 2, 2020 pp 340-343. <http://dx.doi.org/10.31838/jcr.07.02.65>
20. R B R Prakash, P Srinivasa Varma, Pandian A, Prasad Rao K, “Model reference adaptive system (MRAS) technique for sensorless scalar control of induction motor” , International Journal of Scientific and Technology Research (2020), Vol 9, No 3, 3193-3198.
21. Raheema Syed, P. Srinivasa Varma, R. B. R Prakash, Ch. Rami Reddy, “Unit commitment based reliability analysis with contingency constraint”, Indonesian Journal of Electrical Engineering and Computer Science, Vol. 16, No. 1, October 2019, pp. 74-81, DOI: 10.11591/ijeecs.v16.i1.pp74-81