

IOT BASED SUBSTATION MONITORING AND CONTROLLING

¹Mrs. B. Sindhuja, ²Mr. K. Vijaya Kumar, ³Kopparapu Sujindrakumar, ⁴Chappalli Mayin Khanam

^{1,2,3}Assistant Professor, ⁴Student

Department Of EEE

Gouthami Institute Of Technology & Management For Women, Proddatur, Ysr Kadapa, A.P

Abstract— The purpose of this project is to acquire the remote electrical parameters like voltage, current and frequency and send these real time values over network along with temperature at power station. This project is also designed to protect the electrical circuitry by operating a relay. This relay gets activated whenever the electrical parameters exceed the predefined values. This system can automatically update the real time electrical parameters continuously this system can be designed to send alerts whenever the relay trips or whenever the voltage or current exceeds the predefined limits. This project makes use of a microcontroller, as this is a prototype of the proposed project, for demonstration purpose we have used Arduino Uno here. The controller can efficiently communicate with the different sensors being used.

I. INTRODUCTION

Sub-stations are an important part of the power system and a typical sub-station consists of different types of equipment such as transformers, circuit breakers (CB), relays, lightning arresters (LA), current transformers (CT), potential transformers (PT), isolators, capacitors, and so on [1], [2]. In other words, sub-station is the assembly of apparatus used to change some characteristic (e.g., voltage AC to DC, voltage level, frequency, power factor, etc.) of electric supply [3]. Usually, the sub-stations are monitored and controlled manually, or by using expensive PLCs and SCADA system which required more manpower and involved a higher maintenance cost [4]. Under the conventional protection of sub-station especially in differential protection, the relay often requires pilot wires to operate itself which involves a greater capital cost in addition with a sudden interruption of relay operation. To mitigate the mentioned disadvantages, IoT based sub-station monitoring and controlling offers a promising solution with a fully automated system ensuring a greater level of reliability, and thereby increase of the system

performance with the efficient use of the equipment.

“Internet of Things” in short form IoT is created from the word “Internet” and “Things” where “Things” refers to any internet connected device [5]. The Internet of Things (IoT) is a system of interrelated computing devices, mechanical and digital machines, objects, animals or people that are provided with a unique identifier and the ability to transfer data over a network without requiring human-to-human or human-to-computer interaction. In recent years, the IoT is augmented with sensors and actuators, the technology becomes an instance of the more general class of cyber-physical-systems, which also encompasses technologies such as smart grids, virtual power plants, smart homes, intelligent transportation, and smart cities [6], [7]. Because of low-cost, networkable micro-controller modules, the Internet of Things is considered as the key technology to establish a smart sub-station. However, IoT itself has still not reached into maturity and many IoT communication protocols such as CoAP [8] MQTT [9], XMPP [10] have been proposed as IoT standards. These protocols vary in

characteristics with different strengths and limitations [11]. Finally, due to the technological revolution all over the world, smart technologies are replacing the old ones [12], [13]. In the power sector, IoT technology is becoming more attractive nowadays. It is expected that within 2020, around 20–50 billion things would be connected to the internet throughout the world [14], [15].

The main aim of this work is to develop a fully automated IoT based sub-station by which associated equipment can be protected, monitored and controlled from any place in the world only by the authorized personnel at a very low cost. Reliability and reduction of manpower using IoT technology are also the prime concerns while developing smart sub-station framework.

The rest of the paper is organized as follows. A thorough review of related studies is discussed in Section 2. Section 3 illustrates the system model highlighting the major parts of the system. Section 4 represents the experimental setup along with the practical circuit diagram. Section 5 includes the results and discussion. Finally, Section 6 concludes this paper.

II. EXISTING METHOD

The existing system substation monitoring over GSM the complexity of distribution network has grown, automation of substation has become a need of every utility company to increase its efficiency and to improve the quality of power being delivered. The proposed project which is IOT based controlling of the substation will help the utility companies, by ensuring that their local-substation faults are immediately realized and reported to their concerned departments via IOT, to provide that term of intensity intrusion is decreased. The measured parameters will send as SMS messages. The microcontroller will cooperate with the sensors introduced at the nearby substation and perform a task as

commanded. Electrical parameters like current, voltage will be compared continuously to its rated value will help protect the distribution and power transformer from burning due to overload, short circuit fault, overvoltage's, and surges. In this manner, the observing and working effectiveness of the sub-station will definitely increment.

III. PROPOSED SYSTEM

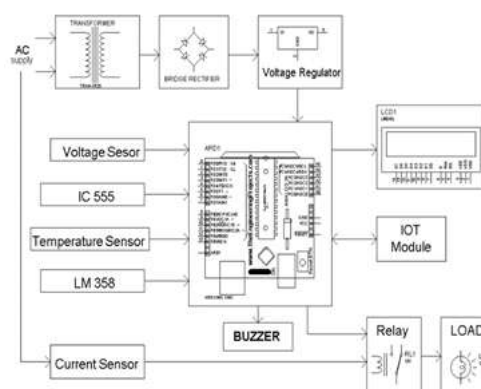

Fig -2: Block Diagram of Substation monitoring and controlling using Arduino

The complete automatic substation monitoring and controlling consist of following part

3.1 Power supply

Most of time embedded system circuit uses 12 volts. 5-volt DC is used as its operating voltage. It's necessary to change the 230 Volt A C supply to the essential D C supply. Firstly 12 volts ac supply is obtained by using stepdown transformer by reducing the 230 Volt supply to 12 volts. In this project the potential transformer (PT) outputs can be used in its place rather than going for another different step-down transformer. By rectification process, the 12 Volts A C is converted in to a 12 Volts pulsating DC voltage. The pulsating D C is then sent to a capacitive filter for smoothening and a standard 12

Volt DC is obtained as an output.

3.2 Potential transformer

They convert A.C from one level to another voltage level along with some loss of power. The P T utilizes a step-down transformer to lessen hazardously higher voltage to a more secure lower voltage in any substation. Potential Transformer used in automatic power factor correction project steps- down the supply voltage from 230 V to 12 V as needed by circuit to work. Potential Transformers output is usually used for measuring and also various monitoring purposes.

3.3 Current transformer

In an electrical circuit, currents are measured by using a CT. At point when current is exceptionally high to straightforwardly apply to measuring instruments, the C T creates a decreased current, that can be suitably connected with measuring and recording instruments.

3.4 IoT Module

This module has a powerful enough on-board processing and storage capability that allows it to be integrated with the sensors and other application specific devices through its GPIOs with minimal development up-front and minimal loading during runtime.

3.5 Arduino

An Arduino was born at the Ivrea Interaction Design Institute as an easy tool for fast prototyping, aimed at students without a background in electronics and programming. As soon as it reached a wider community, the Arduino board started changing to adapt to new needs and challenges, differentiating its

offer from simple 8-bit boards to products for IoT applications, wearable, 3D printing, and embedded environments.

3.6 RELAY UNIT

The relay unit controls the high-power circuit from a low power circuit because microcontroller's output cannot control direct switching of capacitors. Relay is defined as an electrically operated switch. When there is a need to control in a circuit by a low power signal in such cases relays are used. Current that passes from coil of relay generates a magnetic field that gets attracted towards lever and then the switch contacts are changed. Connections of relay's switch are Common, Normally Open (NO), normally closed (NC). Relay coil is not operated by the current provided by the output of microcontroller as current is insufficient.

3.7 DISPLAY UNIT

An embedded system communicates directly to a human being by use of input and output devices. It should be noticed that in an embedded system, the interaction is instigated by the microcontrollers. The system uses input and output devices those generate direct communications with human being. LCD display can be considered as the most common devices that is connected to the microcontroller. Specifying the types of LCD displays, 16x2 and 20x4 are the most common ones connected to the microcontrollers. These digits indicate the numbers of the characters and the numbers of the lines. For example, a 16x2 LCD display contains 16 characters and 2 lines made available to use. Similarly, 20x4 LCD display indicates 20 characters and 4 lines made accessible for use. In this project a 16x2 LCD display, is considered.

IV. RESULTS



The Project “**IoT Based Substation Monitoring and Controlling**” was designed such that to provide automation of the substation which increase transformer life, reduce faults and increase stability. It increases the efficiency of the system. This leads to accurate and reliable operations. It will provide fast and easy monitoring with more efficient way as compared to existing manual monitoring of the sub-station

V. CONCLUSION

This project describes a monitoring system for distribution transformers using IoT communication. It is also easy to install and use. It may reduce human efforts with the automation of the substation which increase transformer life, reduce faults and increase stability. It increases the efficiency of the system. This leads to accurate and reliable operations. It will provide fast and easy monitoring with more efficient way as compared to existing manual monitoring of the sub-station

REFERENCES

A. Sachan, "Microcontroller based substation monitoring and control system with GSM modem, " IOSR Journal of Electrical and Electronics Engineering, Vol. 1, no. 6, pp. 13-21, Aug. 2012. 2. S. M. Ayala, B. J. Galdenoro, and O.A.A. Maldonado, "AI automates substation control, "Computer Applications in Power, Vol. 15, no. 1, pp. 41-46, Feb. 2002. 3. V.K Mehta and R. Mehta, " Principles of power system, " S. Chand & Company Ltd., 3rd edition.

A. John, R. Varghese, S. S. Krishnan, S. Thomas, T. A. Swayambu and P. Thasneem, "Automation of 11 kV substation using raspberry pi," International Conference on Circuit, Power and Computing Technologies (ICCPCT), Kollam, pp. 1-5, Apr. 2017. 5. S. Madakam, R. Ramaswamy, and S. Tripathi, "Internet of Things (IoT): A literature review," Journal of Computer and Communications, Vol. 3, no. 5, pp. 164, May. 2015. 6

D. Mocrii, Y. Chen, and P. Musilek, "IoT-based smart homes: A review of system architecture, software, communications, privacy and security," Internet of Things, Vol. 1-2, pp. 81-98, Sep. 2018. 7. D. Mocrii, Y. Chen, and P Musilek, "IoT-based smart homes: A review of system architecture, software, communications, privacy and security," Internet of Things,