

## DESIGN AND ANALYSIS OF E-VEHICLE FRAME

Karimulla Syed<sup>1</sup>, K. Prasanth Kumar Reddy<sup>1</sup>

<sup>1</sup>Dept. of Mechanical Engg., Koneru Lakshmaiah Education Foundation (KLEF), Vaddeswaram, Green fields, Guntur, Andhra Pradesh, India -522302

DOI : 10.48047/IJFANS/11/ISS4/116

**Abstract** - In order to reduce carbon emissions, the world is going toward electric infrastructure vehicles, however it is clear that IC engine frames are different from those of electric vehicles. Because they are economical and environmentally friendly, e-bikes are favoured for transportation. As part of gift research, the ideal design for an electric bike was sculpted and evaluated for stress and failure rate for industrial application. The bike's frame is its skeleton; it holds and supports the entire weight. The major objective of the article was to develop and construct a lightweight weight that was nevertheless more reliable, secure, and affordable than conventional ones. The fabric is AISI-standard fabric. The research employed static simulations and torsional evaluations for abrupt impact.

### 1.INTRODUCTION

India has been controlled by the ever-increasing need for gasoline and diesel for millennia, necessitating a non-negotiable solution, particularly in India. Since it is so important, people have started studying alternative energy sources for transportation in an effort to improve it. By removing the obstacle, electrical automobiles offered ground-breaking answers to meet the demands, and the industry started to expand. Two-wheeled bicycles known as "electrical bikes" use electricity as their fuel source. Electrically driven motorbikes have no noise, no emissions, and no environmental impact. The battery controls how quickly and how the device works. To increase the scope To boost the power of the electrical drive system, fuel cells and petrol-electric hybrids, which are now under development, might be installed. Electric bikes have proven to be a practical way to reduce pollution more significantly. Enhancing quality is necessary to boost e-bike sales. The aforementioned study led to the development of lighter frames for e-bikes than for ordinary cycles in order to increase their efficiency.

**C.H. Neeraja** All of the "Structural Analysis of The Two-Wheeler Suspension Frame" models a two-wheeler suspension frame. Pro/Engineer is used to create the models. To confirm our design, they performed structural and modal analyses on the suspension frame using four materials: aluminum, steel, alloy A360, magnesium, and carbon fibre reinforced p alloy A360, polymer. The stress levels for all of the materials are lower than their respective allowed yield stress values, as seen in the findings. The conclusion of the process is that the design was shown to be safe.

**Yaşar Kahraman** Used finite analysis to optimize the chassis; the main goal was to reduce the chassis' weight; for this, used three thicknesses: 4 ,5 and 6 mm; after the analysis, they concluded that the 4 mm is superior due to its higher stress and displacement values than the other two thicknesses.

### FRAME MATERIAL

It is critical to choose the right frame material. Carbon fibre, Titanium grades, AISI 4130, AISI 4140, and AISI 1080 materials were used because they have the best necessary qualities. The material is selected depending on its cost and availability on the market.

**Selected Frame Material:** American Iron and Steel Institute (AISI 4130).

AISI 4130 offers a high level of strength, toughness, and ductility. The density is lower. All traditional processes may be used to weld and manufacture AISI 4130. As a result, this material is appropriate for fabrication processes such as welding, cutting, finishing, grinding, and so on.

### CHASSIS

The chassis is the basis of a vehicle, and it is even referred to as a skeleton for a vehicle that supports an artificial aim in its design and provides protection for integrated pieces in the vehicle. A MULTITRELLIS café style chassis is assembled with

several neck joints attached at the steering tube with certain cross members, metallic plates to joint support single seat and mounted joints to integrate motors and innovations, and metal mounts to support rear suspension.

### Different Type of Chassis

- Single Cradle Frame
- Double Cradle Motorcycle Frame
- Backbone Frame
- Perimeter Frame
- Monocoque Motorcycle Frame
- Trellis Frame

## 2.DIMENSIONS

**Table 1** Dimensions o the frame

ITEM	TYPE/DIMENSIONS
Grade	AISI 4130
Pipes	1-inch diameter, 2mm thickness (seamless)
Bulk Modulus	140 GPa
Modulus of Elasticity	190-210 GPa
Density	7.85 gm/cm <sup>3</sup>
Poisson Ratio	0.27-0.30
Tensile Strength (Ultimate/Yield)	560/460 MPa
Shear Modulus	80 GPa

## DESIGN & ANALYSIS

Solid works is a design software tool used to generate and build models of an object/component that incorporates multiple performance operations, design modulators, traditional drawing techniques by the integrity of sophisticated sketching mounts. To build our bike frame, we utilized Solid Works 18.0.

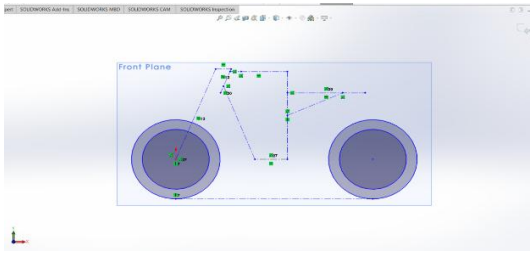

Fig 1 - 2D Design of E-vehicle frame

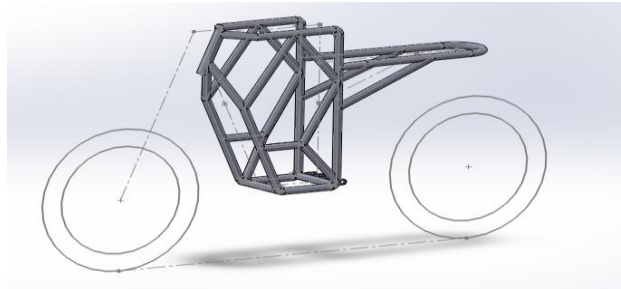

Fig 2- 3D Modeling of E-vehicle frame

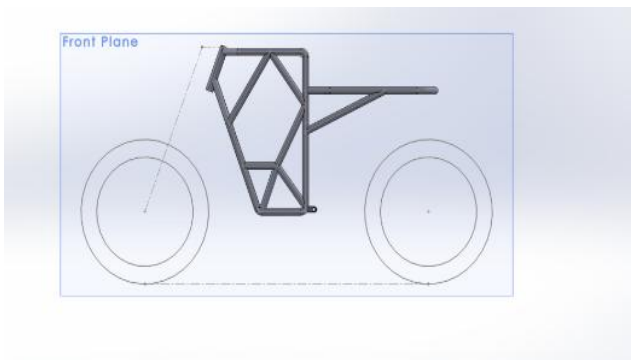

Fig 3-Front Views

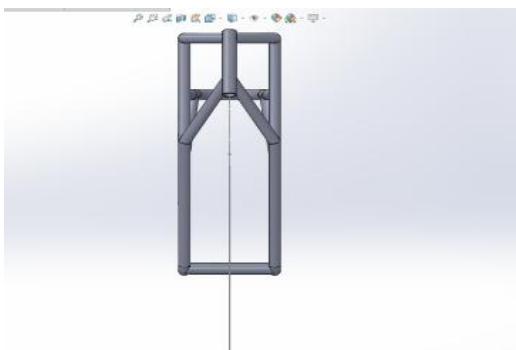

Fig 4-Side Views

### 3.ASSEMBLED VIEW

Assembly is a CAD tool that includes merging, importing multilateralist items into a single component in either 2-D or 3 D orientation with clearance interface handling single and multi-points with varied intersections of components.

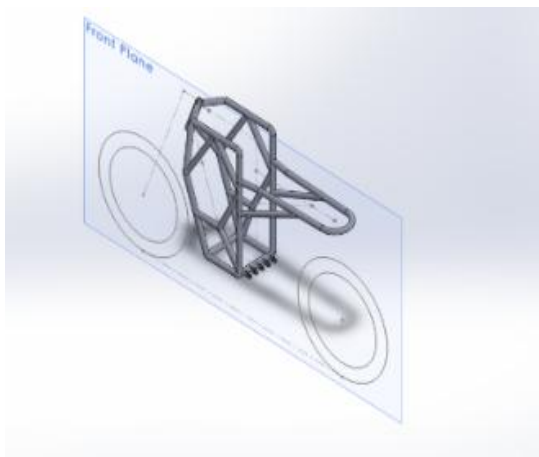

Fig 5- isometric view of chassis

Tabel 2- TECHNICAL SPECIFICATIONS

Wheel Base	1170mm
Length	1220mm
Width	730 mm
Height	1126 mm
Rake Angle	19°
Head Tube Angle	19°
Final Drive Ratio	1:3.38
Ride Height	920mm
Tires	Front 18" (90/90) Back 18" (100/90)
CG Point	0.41 m
Trail	7 cm
Turning Radius	745 mm

#### 4.FINITE ELEMENT ANALYSIS

To establish the bike's performance in various conditions, the frame was submitted to Finite Element Analysis (FEA). These tests were performed to evaluate the deformation and strength of the bike when it was subjected to various loads throughout the course of its life. FEA was carried out using the ANSYS 16.1 programme version. The strength and deformation of the frame are depicted in the figures. The maximum von-mises stress was determined to be 134.6 MPa with a maximum deformation of 0.4931 mm after the stress was examined under various situations. The majority of the strains, according to the research, have a value less than 120 MPa.

Von-mises was used to test the design to see if it could withstand the necessary load. The design will fail if the maximum value of the von-mises exceeds the material's strength. As an outcome the von-mises stress does not surpass the strength of the material. According to research, the maximal von-mises stress is 134.16 MPa.

Tot Def.: - 0.6624mm (Max) AND 0 to 0.07mm (Min)

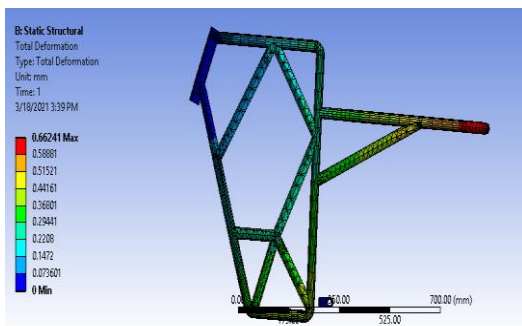

Fig 6- Tot Deformation .

Von mises stress: -101.61MPa (Max)

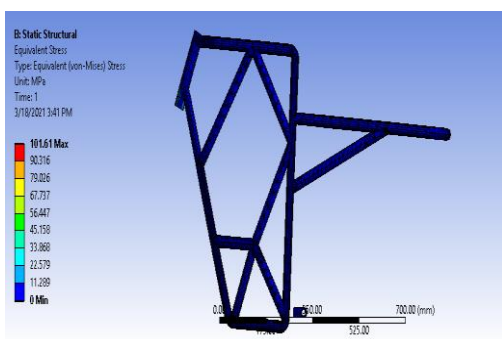

Fig 7- Equivalent Stress of frame

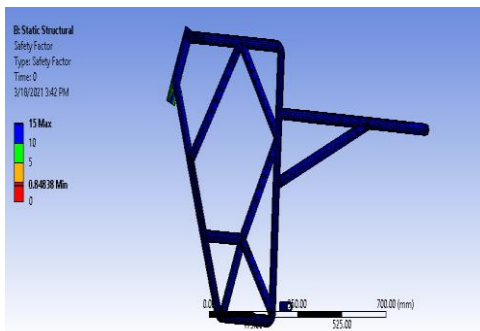

Fig 8- Safety Factor of frame

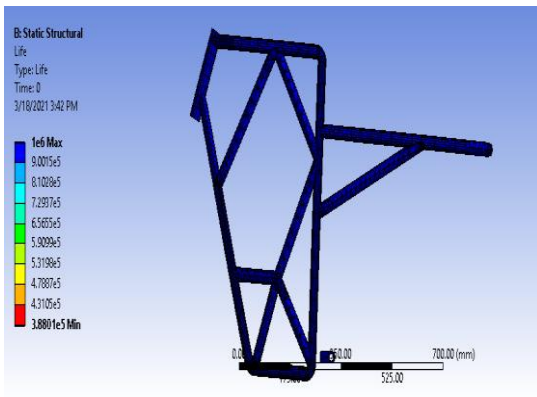

Fig 9-Life of frame

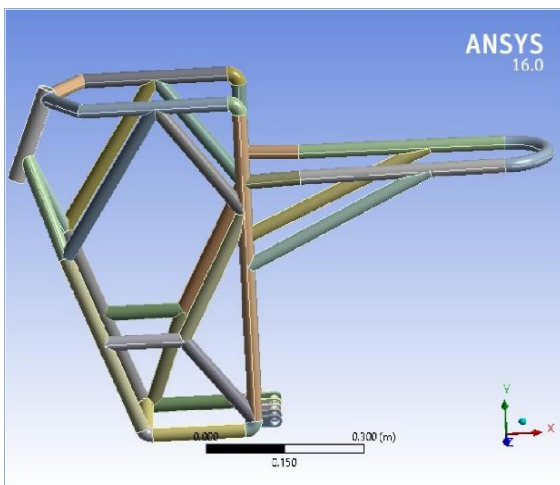

Fig 10 – total output

5.CONTENTENTS

- Mesh
- Loads
- Results

Object Name	Mesh
State	Solved
<b>Display</b>	
Display Style	Body Color
<b>Defaults</b>	
Physics Preference	Mechanical
Relevance	0
<b>Sizing</b>	
Use Advanced Size Function	Off

Tabel 3- Model (A4) > Mesh

Relevance Center	Fine
Element Size	Default
Initial Size Seed	Active Assembly
Smoothing	Medium
Transition	Fast
Span Angle Center	Coarse
Minimum Edge Length	1.2764e-004 m
<b>Inflation</b>	
Use Automatic Inflation	None
Inflation Option	Smooth Transition
Transition Ratio	0.272
Maximum Layers	5
Growth Rate	1.2
Inflation Algorithm	Pre
View Advanced Options	No
<b>Patch Conforming</b>	
<b>Options</b>	
Triangle Surface Mesher	Program Controlled
<b>Patch Independent</b>	
<b>Options</b>	
Topology Checking	No
<b>Advanced</b>	
Number of CPUs for Parallel Part Meshing	Program Controlled
Shape Checking	Standard Mechanical
Element Midside Nodes	Program Controlled
Straight Sided Elements	No
Number of Retries	Default (4)
Extra Retries for Assembly	Yes
Rigid Body Behavior	Dimensionally Reduced
Mesh Morphing	Disabled
<b>Defeaturing</b>	
Pinch Tolerance	Please Define

Generate Pinch on Refresh	No
Automatic Mesh Based Defeaturing	On
Defeaturing Tolerance	Default
<b>Statistics</b>	
Nodes	62818
Elements	20902
Mesh Metric	None

Tabel 4-Model (A4) &gt; Static Structural (A5) &gt; Loads

Object Name	<i>Fixed Support</i>	<i>Fixed Support 2</i>	<i>Force</i>	<i>Force 2</i>
State	Fully Defined			
<b>Scope</b>				
Scoping Method	Geometry Selection			
Geometry	10 Faces	1 Face		
<b>Definition</b>				
Type	Support	Fixed	Force	
Suppressed	No			
Define By			Vector	
Magnitude			1000. N (ramped)	
Direction			Defined	

Tabel 5 -Model (A4) &gt; Static Structural (A5) &gt;Solution (A6) &gt; Results

Object Name	<i>Total Deformation</i>
State	Solved
<b>Scope</b>	
Scoping Method	Geometry Selection
Geometry	All Bodies
<b>Definition</b>	
Type	Total Deformation
By	Time
Display Time	Last
Calculate Time History	Yes



Identifier	
Suppressed	No
<b>Results</b>	
Minimum	0. m
Maximum	1.5053e-002 m
Minimum Occurs On	Part 1
Maximum Occurs On	Part 18
<b>Information</b>	
Time	1. s
Load Step	1
Substep	1
Iteration Number	1

## 6.OUTPUT

Fig 11- Total Deformation

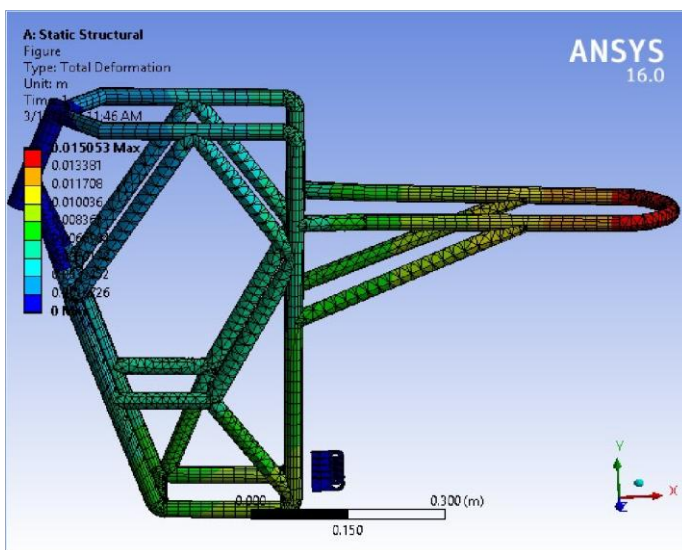

## 6.1CONCLUSION

- Using the results that are illustrated in the paper, the overall strategy is secure, convincing, portable, and suitable for the needs.
- Analysis results also become much more reliable, but other tests, like the exhaustion test and claspings, can still be carried out to find out whether our results are risky or reliable.
- AISI 4130 can be replaced with a variety of materials, including titanium and carbon fibre.
- The plan is limited by the titanium and carbon fibre composite because they are both pricey. It appears to be much more sturdy than the stuff we used. As a result, the qualified candidate may be selected depending on the requirement.
- The stacking requirements were limited since AISI 4130 was utilised, but they might be enhanced if a different, more grounded material was selected.

## 7.PROPOSED FUTURE WORK

The spine type outline serves as the foundation for the complete design of the paper, so if Monocoque or another type of casing is employed, the outcome should be assessed to see if it is likely to be higher and more durable than is necessary. However, the design of the casing that this article handles can be improved from a number of angles to obtain a common and effective vehicle construction depending on the varied requirements. Although different materials can be used in their place and examined for

increased competence, the accessibility, machinability, and cost of each material must all be taken into consideration. The inquiry by Swing Arm is currently ongoing.

## REFERENCES

1. Abagnalea C, Cardoneb M, Iodicea P, Marialtoc R, Stranoa S, Terzoa M, Vorraroabc G., Design and Development of an Innovative E-Bike. *Energy Procedia*, 101, 2016, 774-781.
2. Ifeanyichukwu U. Onyenanu, Swift ONK, Atanmo PN, Design and Analysis of a Tubular Space Frame Chassis for FSAE Application, *Journal of Emerging Technologies and Innovative Research*, 2 (10), 2015, 497 -201.
3. Sagar Pardeshi 1, Pankaj Desle 2, Design and Development of Effective Low Weight Racing Bicycle Frame, *International Journal of Innovative Research in Science, Engineering and Technology*, 3(12), 2014, 18215 - 18221.
4. Hochman, J.B.; Rhodes, C.; Kraut, J.; Pisa, J.; Unger, B. End User Comparison of Anatomically Matched 3-Dimensional Printed and Virtual Haptic Temporal Bone Simulation: A Pilot Study. *Otolaryngol. Head Neck Surg.* 2015, 153, 263–268.
5. Hochman, J.B.; Rhodes, C.; Wong, D.; Kraut, J.; Pisa, J.; Unger, B. Comparison of cadaveric and isomorphic three-dimensional printed models in temporal bone education. *Laryngoscope* 2015, 125, 2353–2357.
6. Longfield, E.A.; Brickman, T.M.; Jeyakumar, A. 3D Printed Pediatric Temporal Bone: A Novel Training Model. *Otol. Neurotol.* 2015, 36, 793–795. Rose, A.S.; Kimbell, J.S.; Webster, C.E.; Harrysson, O.L.; Formeister, E.J.; Buchman, C.A. Multi-material 3D Models for Temporal Bone Surgical Simulation. *Ann. Otol. Rhinol. Laryngol.* 2015, 124, 528–536.
7. Xiong, L.; Li, X.; Li, H.; Chen, Z.; Xiao, T. The efficacy of 3D printing-assisted surgery for traumatic fracture: A meta-analysis. *Postgrad. Med. J.* 2019, 95, 414–419.
8. Han X, Yang YD, Spintzyk C, Scheideler S, Li L P (2019) Carbon fiber reinforced PEEK composites based on 3D-printing technology for orthopedic and dental applications. *J Clin Med* 8(2):240
9. Zhang Y, Yu W, Ba Z, Cui S, Wei J, Li H (2018) 3D-printed scaffolds of mesoporous bioglass/gliadin/polycaprolactone ternary composite for enhancement of compressive strength, degradability, cell responses and new bone tissue ingrowth. *Int J Nanomed* 13:5433–5447
10. Habib A, Khoda B (2019) Development of clay based novel hybrid bio-ink for 3D bio-printing process. *JManuf Process* 38:76–87