

Advanced Security System Using Raspberry PI

P. Kumar¹, M. S. Tanveer Basha²

^{1,2}Assistant Professor, Department Of ECE, CVRT Engineering college, Tadipatri

ABSTRACT

Security is the primary concern everywhere and for everyone. Every person wants their home, industry etc to be secured. This project describes a security system that can monitor an industry and home. This is a simple and useful security system and easy to install. Here our application uses Raspberry Pi as its controller and passive infrared sensor which detects the presence of a person wherever we place this module either at a door near home or at offices, factories or any other place where we need monitoring every minute for the purpose of security.

PIR sensor detects the movement around the sensor to activate the webcam to capture a picture. If the suspicious object is detected, then the alarm is activated and sends the images to cloud through IOT to warn the house owner about the existence of the intruder. so that one can have the knowledge of the person who appeared at that instant. A buzzer rings to alert surrounding people in that case.

1. INTRODUCTION

1.1 Introduction

Today technology plays a vital role in our daily life. There is rapid growth in technology in the field of security systems. The term motion detection is becoming very common in the present scenario when and where the safety and security are playing a key role in supervising and also these systems slowly becoming a part of many locations including traffic areas, shopping malls, institutions and several organizations and even it is also used for home security. A raspberry pi security camera system can have many benefits such as reduced theft, protect employees, building security, remote monitoring of the facility from Smartphone or tablet, deter trespassers from attempting to gain access to the facility. The problematic surveillance system or CCTV camera is costly because of the use of many expensive components like computers, cameras, and cable. Also, we need a hard disk with higher capacity to save video. It reserves too much space for continuous recording and requires manpower to detect the unauthorized activity.

In the raspberry pi security system, the camera captures images of the person whenever PIR senses the presence of an individual and our controller sends those images to the pre-stored cloud through a computer network. in order that one will have the data of the person appeared at that instant. A vibration detector is additionally connected to spot if somebody tries to open the door and a siren is given to alert encompassing folks in this case. Unlike the problematic surveillance system, raspberry pi security system is of low cost and also has additional features such as alerting the owners by sending pictures to the cloud. In this system the email notification feature helps the user to see what is wrong than to see the entire video to find the error. The Raspberry Pi system is not only user friendly it also enables an individual with medium knowledge to assemble the system if the necessary raw material is available and by creation of some extra files to support the operating system to store the data. So they are not only a money saving project but also a efficient security system.

1.2 Block diagram

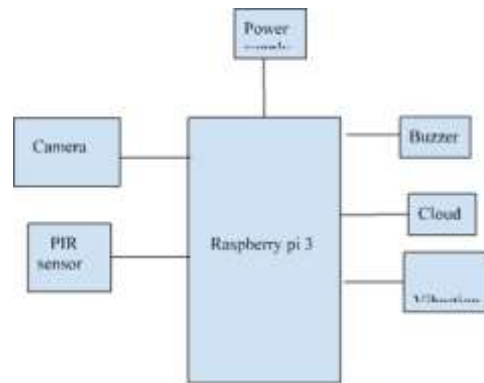

Figure 1. Block diagram of advanced security system

2. LITERATURE SURVEY

2.1 Advance Security System with Intruder Image Capture and Forward Through Email by Koluguri Neelima¹, K.Ashok kumar².

Here the application uses Raspberry Pi as its controller and PIR detector that detects the presence of an individual wherever ever we tend to place this module either at a door close to home or at offices, factories or the other place wherever we'd like watching each minute for the aim of security. The camera image of the person is captured whenever PIR senses the presence of an individual and our controller sends those images to the pre-stored email address through the computer network. in order that one will have the data of the person appeared at that instant.

2.2 “A Smart Visitor’s Notification System with Automatic Secure Door Lock using Mobile Communication Technology” by Marwa Khalid¹, Sadia Majeed².

This paper presents an automatic security system to automate the entry of holiday makers, providing a lot of flexibility of managing their record and securing homes or workplaces. Face recognition is an element of this method to attest the guests.

This method functions in real time as once the visitor arrives, it'll find and acknowledge his face and on the results of face recognition method. It'll open the door for licensed guests or notifies and permits the owners to require any action just in case of unauthorized visitor. The planned system is developed and it's with success guaranteeing security, managing records and in operation gate while not physical interaction of owner.

2.3 SMS-based Home Automation System by A. Alheraish

A home automation system is proposed using SMS. The proposed system detects illegal intrusions at home and allows legitimate users to change the passkey for the door and control lights in the home. The illegal intrusion into the home is identified by monitoring the state of the home door, which is done using Light Emitting Diode (LED) and infrared sensors. The passkey to the door can be any 4 digits, which can be set either by using the keypad or by using SMS from a registered user’s mobile number. A user can control the lights in their home remotely using SMS from their registered mobile number; by turning the lights on in different rooms at random intervals of time, one can give the impression that the home is occupied, even when it is not.

3. HARDWARE DESCRIPTION

RASPBERRY PI

Raspberry Pi is defined as a minicomputer the size of a credit card that is interoperable with any input and output hardware device like a monitor, a television, a mouse, or a keyboard – effectively converting the set-up into a full-fledged PC at a low cost.

The first generation of computers came as massive processing systems built with vacuum tube technology. Over the years, more compact and less expensive versions of what a computer would come to look like sprung up. Today, we have minicomputer gadgets such as smartphones in our pockets. Even though computers have become so commonplace, they are still not widely accessible in developing countries. This imbalance in access to computers and programming technology led to the development and creation of the Raspberry Pi computer.

Raspberry Pi is a small, low-cost, single-board computer the size of a credit card that allows people from different backgrounds and levels of expertise to experience and learn to compute. It is an enhanced motherboard developed in the United Kingdom by the Raspberry Pi foundation, now widely accepted as a part of evolving computer technology. The minicomputer can connect with other peripheral hardware devices such as a keyboard, mouse, and monitor.

One can use Raspberry Pi for various purposes, including learning programming languages and orchestrating network management. It is multifunctional and gained even more popularity in the past few years than initially projected.

Raspberry Pi is a programmable device. It comes with all the critical features of the motherboard in an average computer but without peripherals or internal storage. To set up the Raspberry computer, you will need an SD card inserted into the provided space. The SD card should have the operating system installed and is required for the computer to boot. Raspberry computers are compatible with Linux OS. This reduces the amount of memory needed and creates an environment for diversity.

After setting up the OS, one can connect Raspberry Pi to output devices like computer monitors or a High-Definition Multimedia Interface (HDMI) television. Input units like mice or keyboards should also be connected. This minicomputer's exact use and applications depend on the buyer and can cover many functions.



Fig 2 Raspberry pi 3

4. IR SENSOR

4.1 Introduction

IR sensor is an electronic device that emits light in order to sense some object of the surroundings. An IR sensor can measure the heat of an object as well as detect the motion.

Usually, in the infrared spectrum, all the objects radiate some form of thermal radiation. These types of radiation are invisible to our eyes, but infrared sensors can detect these radiations



4.2 PIR sensor

PIR sensor detects a human being moving around within approximately 10m from the sensor. This is an average value, as the actual detection range is between 5m and 12m. PIR are fundamentally made of a pyro electric sensor, which can detect levels of infrared radiation. For numerous essential projects or items that need to be discovered when an individual has left or entered the area. PIR sensors are incredible, they are flat control and minimal effort, have a wide lens range, and are simple to interface with.

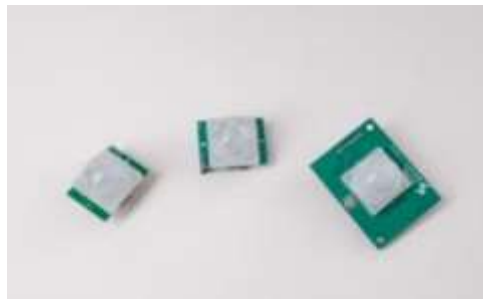

Fig 3 PIR sensor

4.3. Vibration sensor

At present in the industry like research and development, the ability of monitoring, measuring as well as analyzing the vibration is very important. Unfortunately, the suitable techniques for making a measurement system for vibration with precise & repeatable are not always clear to researchers with the shades of test tools & analysis of vibration. There are some challenges related while measuring the vibration which includes a selection of suitable components, the configuration of the system, signal conditioning, analysis of waveform and setup.

The vibration sensor is also called a piezoelectric sensor. These sensors are flexible devices which are used for measuring various processes. This sensor uses the piezoelectric effects while measuring the changes within acceleration, pressure, temperature, force otherwise strain by changing to an electrical charge. This sensor is also used for deciding fragrances within the air by immediately measuring capacitance as well as quality.



Fig 4 Vibration sensor

4.4 Camera

A webcam is a small digital video camera directly or indirectly connected to a computer or a computer network. Webcams come with software that needs to be installed on the computer to help users record video on or stream it from the Web. Webcams are capable of taking pictures as well as high-definition videos, although the video quality can be lower compared to other camera models.

Webcams are also known as Web cameras. A webcam is an input device that captures digital images. These are transferred to the computer, which moves them to a server. From there, they can be transmitted to the hosting page. Laptops and desktops are often equipped with a webcam.



Figure 5 Camera

4.5. Buzzer

A buzzer is a small yet efficient component to add sound features to our project/system. It is a very small and compact 2-pin structure hence can be easily used on breadboard, Perf Board and even on PCBs which makes this a widely used component in most electronic applications.

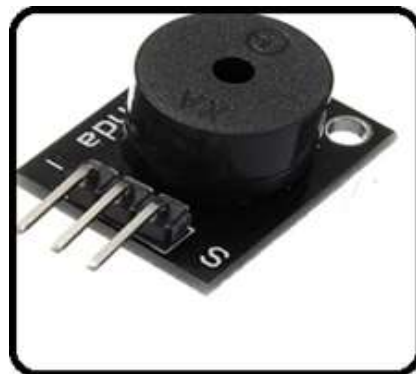

Fig 6 Buzzer

There are two types of buzzers that are commonly available. The one shown here is a simple buzzer which when powered will make a Continuous Beeeeep.... sound, the other type is called a readymade buzzer which will look bulkier than this and will produce a Beep. Beep. Beep. Sound due to the internal oscillating circuit present inside it. But, the one shown here is most widely used because it can be customized with help of other circuits to fit easily in our application.

This buzzer can be used by simply powering it using a DC power supply ranging from 4V to 9V. A simple 9V battery can also be used, but it is recommended to use a regulated +5V or +6V DC supply. The buzzer is normally associated with a switching circuit to turn ON or turn OFF the buzzer at required time and required interval.

5. RESULT

The project has been tested in an empty closed premises where a person was made to enter into the premises. The PIR sensor when detected the presence of a person will send a signal to the microcontroller. After the microcontroller receives the signal , the camera will capture the image of the person and sends it to the owner of the premises through IOT. Thereafter buzzer makes sound

The proposed demonstrated great performance and accurate execution results at the time of testing.

After many observations of the outcome the result was approximately the same in many cases.



Figure 7 Working Module of advanced security system

5.2 Advantages of the project

- Highly flexible
- No need of human effort
- High security is provided

5.3 Drawbacks of the project

- It just detects the intruder entering into the property but doesn't stop the intruder from entering inside the property.
- It cannot be used in remote places where the network does not exist.

5.4 Applications

Used to detect intruders and enhance security at:

- Museums

- ●Home
- ● Office
- ●Jewelry shops
- ●Banks

6. CONCLUSION AND FUTURE SCOPE

6.1 Conclusion

This project was all about the design and construction of a system that is able to detect when an intruder enters an area and sends the pictures of the intruder. The system utilizes the Raspberry Pi 3 microcontroller. The system worked satisfactorily and as expected. This system allows for faster transmission of the intruder alert, can be assessed from anywhere and anytime and is an economical means of surveillance. This can be used for many applications in security purpose for Houses, Banks, Jeweler shop.

6.2 Future scope

A security system can be designed which not only detects the presence of a person but also prevents the unknown person from entering the premises. This method functions in real time as once the visitor arrives, it'll find and acknowledge his face and on the results of face recognition method, it'll open the door for licensed guests or notify and permit the owners to require any action just in case of unauthorized visitors.

7. REFERENCES

1. <https://ieeexplore.ieee.org/document/8976710>
2. <https://www.questjournals.org/jecer/papers/vol8-issue5/B08050611.pdf>
3. <https://theijes.com/papers/NCIECE/Q01120116.pdf>
4. <https://circuitdigest.com/microcontroller-projects/raspberry-pi-iot-intruder-alert-system>
5. <https://www.ijert.org/a-smart-intruder-detection-system>
6. <https://www.irejournals.com/formatedpaper/1704242.pdf>
7. <https://www.theengineeringprojects.com/2022/09/security-system-with-image-capturing-in-raspberry-pi-4.html>