

# Implementation of Solar Inverter for Home, Garden, Street Light Applications

C.Madhavi<sup>1</sup>, Dr.M.Ramasekhara Reddy<sup>2</sup>

<sup>1,2</sup>Assistant Professor Department of EEE CVRT Engineering College, Tadipatri.

## ABSTRACT

This paper is written to enhance the use of resources in developed as well as developing countries. In this digital world, use of technology is very advanced and we prefer things to be done automatically without any human efforts. This project also helps to reduce human efforts. Also it is very useful to conserve resources. In today's world, there is a continuous need for automatic appliances. With the increase in standard of living, there is a sense of urgency for developing circuits that would ease the complexity of life. Also if at all one wants to know the number of people present in room so as not to have congestion, this circuit proves to be helpful. "Automatic room light controller with visitor counter" is a reliable circuit that takes over the task of controlling the room lights as well as counting number of persons/ visitors in the room very accurately.

## 1. INTRODUCTION

We see many people using Solar inverters these days which proves that its necessity has been increased in the current years. A Solar inverter is similar to a normal electric inverter but uses the energy of the Sun i.e. Solar energy. A solar inverter helps in converting the direct current into alternate current with the help of solar power. Direct power is that power which runs in one direction inside the circuit and helps in supplying current when there is no electricity. Direct currents are used for small appliance like mobile e phones, MP3 players, iPod etc. where there is power stored in the form of battery. In case of alternative current it is the power that runs back and forth inside the circuit. The alternate power is generally used for house hold appliances. A solar inverter helps devices that run on DC power to run in AC power so that the user makes use of the AC power. If you are thinking why to use solar inverter instead of the normal electric one then it is because the solar one makes use of the solar energy which is available in abundant from the Sun and is clean and pollution free.

Solar inverters are also called as photovoltaic solar inverters. These devices can help you save lot of money. The small-scale grid one have just two components i.e. the panels and inverter while the off grid systems are complicated and consists of batteries which allows users to use appliances during the night when there is no Sunlight available. The solar panel and the batteries that are placed on rooftops attract Sun rays and then convert the Sunlight into electricity. The batteries too grab the extra electricity so that it can then be used to run appliances at night.

Solar energy is becoming increasingly lucrative with the increasing cost and continuous depletion of the non-renewable energy resources and the growing demand of other renewable energy sources such as solar wind, geothermal and ocean tidal wave . However, in spite of the multiple benefits of solar energy, solar panels which capture sunlight are stationary (solar

array has a fixed orientation to the sky). These stationary as well as expensive solar panels are unable to extract the maximum solar energy as there is no stability of weather conditions. The power output of solar panels is maximum when it is oriented perpendicularly to the direction of sun rays as both the area of illumination of sunlight on solar panels and intensity of sun-rays is maximum in this case. It has been found out that the efficiency of solar panels improve by 30-60 percent when we use a mobile solar tracking system instead of a stationary array of solar panels. The design and implementation of a power efficient solar tracker is therefore a challenge owing to the immobility of the solar panels. The angle of inclination of sun-rays with the solar panels continuously changes due to the movement of the sun from east to west because of earth's rotation independent of the weather conditions. Moreover, during cloudy days the situation totally goes berserk. Additionally the revolution of the earth alters the distance between earth and sun which introduces change of pattern of incoming sun rays. All these factors should be kept in mind for designing the solar tracking electricity generation system to achieve maximum efficiency. In this paper, we have discussed about the solar tracking system that we have designed using some LDR's (light dependent resistances), micro-controller (AT89S52), comparator using OPAMP's, a crystal oscillator, stepper motor and stepper motor driver. The basic idea behind this work is that the intensity of light will be sensed by the LDR's separated by a certain angular distance, the comparators will compare the incident light intensity with the intensity of perpendicular incidence. The micro-controller will rotate the stepper motor by the desired angle depending on the output of the comparators via a stepper motor driver circuit to maximize the efficiency. Owing to the change in the location where the device is placed and weather conditions, the intensity of sunlight changes, for which we have made a provision of changing the threshold value by using variable resistance.

## 2. LITERATURE REVIEW

As its name suggests solar inverter is used to convert solar dc power into AC power. Solar panel energy is stored in batteries using solar charge controller. Dc power stored in batteries is converted into AC power using inverter. Inverter is power electronics dc to ac converter. There are many applications of inverters in power system, industrial and domestic usage. Block diagram of solar inverter is shown below. Block diagram of solar inverter given below is self explanatory. But if you have still any question about it, you are welcome to write it in comments.

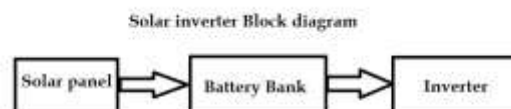

Electronic devices run on AC power, however, batteries and some forms of power generation produce a DC voltage so it is necessary to convert the voltage into a source that devices can use. Hence a need for power rating inverter to smoothly operate electrical and electronic appliances. Most of the commercially available inverters are actually square wave or quasi square wave inverters. Electronic devices run by this inverter will damage due to harmonic contents [1]. Available sine wave inverters are expensive and their output is not so good. For

getting pure sine wave we've to apply sinusoidal pulse width modulation (SPWM) technique. This technique has been the main choice in power electronics because of its simplicity and it is the mostly used method in inverter application [2]. To generate this signal, triangular wave is used as a carrier signal is compared with sinusoidal wave at desired frequency. Advances in microcontroller technology have made it possible to perform functions that were previously done by analog electronic components. With multitasking capability, microcontrollers today are able to perform functions like comparator, analog to digital conversion (ADC), setting input/output (I/O), counters/timer, among others replacing dedicated analog components for each specified tasks, greatly reducing number of component in circuit and thus, lowering component production cost. Flexibility in the design has also been introduced by using microcontroller with capability of flash programming/reprogramming of tasks [3].

### 3. DESIGN OF HARDWARE

This chapter briefly explains about the Hardware. It discuss the circuit diagram of each module in detail.

#### Arduino Uno

The Arduino Uno is a microcontroller board based on the ATmega328 (datasheet). It has 14 digital input/output pins (of which 6 can be used as PWM outputs), 6 analog inputs, a 16 MHz ceramic resonator, a USB connection, a power jack, an ICSP header, and a reset button. It contains everything needed to support the microcontroller; simply connect it to a computer with a USB cable or power it with a AC-to-DC adapter or battery to get started.

The Uno differs from all preceding boards in that it does not use the FTDI USB-to-serial driver chip. Instead, it features the Atmega16U2 (Atmega8U2 up to version R2) programmed as a USB-to-serial converter. Uno board has a resistor pulling the 8U2 HWB line to ground, making it easier to put into DFU mode. Arduino board has the following new features:

- 1.0 pin out: added SDA and SCL pins that are near to the AREF pin and two other new pins placed near to the RESET pin, the IOREF that allow the shields to adapt to the voltage provided from the board. In future, shields will be compatible both with the board that use the AVR, which operate with 5V and with the Arduino Due that operate with 3.3V. The second one is a not connected pin, that is reserved for future purposes.
- Stronger RESET circuit.
- Atmega 16U2 replace the 8U2.

"Uno" means one in Italian and is named to mark the upcoming release of Arduino 1.0. The Uno and version 1.0 will be the reference versions of Arduino, moving forward. The Uno is the latest in a series of USB Arduino boards, and the reference model for the Arduino platform; for a comparison with previous versions, see the index of Arduino boards.



Fig: ARDUINO UNO

### Power Supply:

The power supplies are designed to convert high voltage AC mains electricity to a suitable low voltage supply for electronic circuits and other devices. A power supply can be broken down into a series of blocks, each of which performs a particular function. A d.c power supply which maintains the output voltage constant irrespective of a.c mains fluctuations or load variations is known as “Regulated D.C Power Supply”.

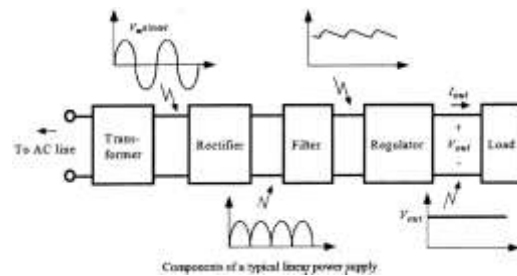

Fig: Block Diagram of Power Supply

### LCD Display

A model described here is for its low price and great possibilities most frequently used in practice. It is based on the HD44780 microcontroller (Hitachi) and can display messages in two lines with 16 characters each. It displays all the alphabets, Greek letters, punctuation marks, mathematical symbols etc. In addition, it is possible to display symbols that user makes up on its own. Automatic shifting message on display (shift left and right), appearance of the pointer, backlight etc. are considered as useful characteristics.



Fig: LCD

**Wifi Module:**

The ESP8266 is a low-cost Wi-Fi microchip with full TCP/IP stack and microcontroller capability produced by Shanghai-based Chinese manufacturer, Espressif Systems.[1] The chip first came to the attention of western makers in August 2014 with the **ESP-01** module, made by a third-party manufacturer, Ai-Thinker. This small module allows microcontrollers to connect to a Wi-Fi network and make simple TCP/IP connections using Hayes-style commands. However, at the time there was almost no English-language documentation on the chip and the commands it accepted.[2] The very low price and the fact that there were very few external components on the module which suggested that it could eventually be very inexpensive in volume, attracted many hackers to explore the module, chip, and the software on it, as well as to translate the Chinese documentation.[3]

The **ESP8285** is an ESP8266 with 1 MiB of built-in flash, allowing for single-chip devices capable of connecting to Wi-Fi.[4]

The successor to these microcontroller chips is the ESP32.

**Photovoltaic Inverter****3.1 Introduction to PV system**

The basic block diagram of grid connected PV power generation system is shown in Fig. 3.1. The PV power generation system consists of following major blocks:

1. PV unit
2. Inverter
3. Grid
4. MPPT

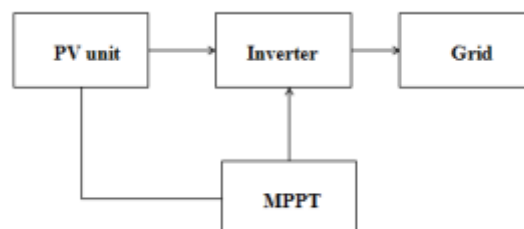

Fig. Schematic diagram of PV system

**Photovoltaic Cell and Array Modeling**

A PV cell is a simple p-n junction diode that converts the irradiation into electricity. Fig.3.2 illustrates a simple equivalent circuit diagram of a PV cell. This model consists of a current source which represents the generated current from PV cell, a diode in parallel with the current source, a shunt resistance, and a series resistance.

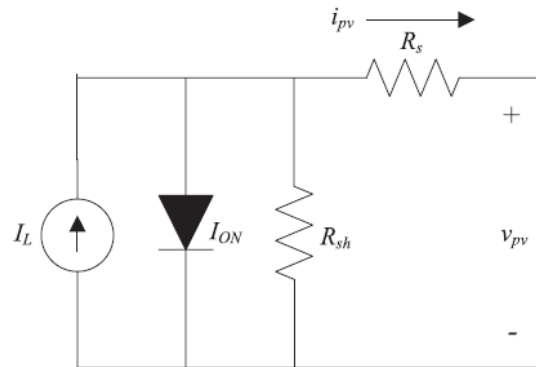

Fig. Equivalent circuit diagram of the PV cell

### Voltage Regulator:

As the name itself implies, it regulates the input applied to it. A voltage regulator is an electrical regulator designed to automatically maintain a constant voltage level. In this project, power supply of 5V and 12V are required. In order to obtain these voltage levels, 7805 and 7812 voltage regulators are to be used. The first number 78 represents positive supply and the numbers 05, 12 represent the required output voltage.

### Inverter

The energy derived from Sun is a renewable one and is totally free of cost. We have learnt how the solar inverter helps in providing electricity and now we shall learn how a solar inverter is made. A solar panel is capable enough to convert the heat or energy of the Sun into direct current.

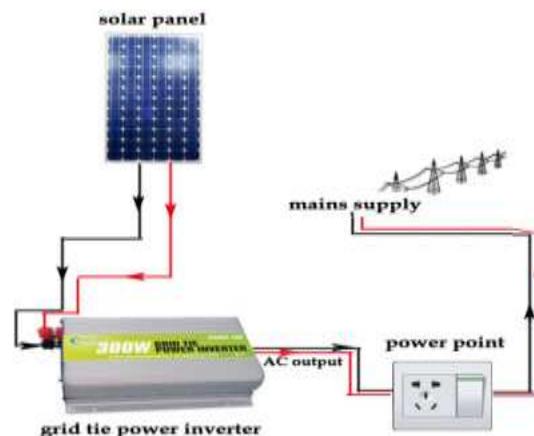

### Solar Inverter Design:

To easily understand the construction of a solar inverter let's discuss the following construction sample:-



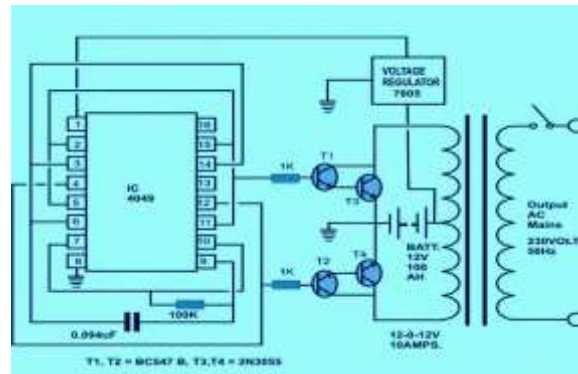

### Ir Sensor

Infrared is a energy radiation with a frequency below our eyes sensitivity, so we cannot see it Even that we cannot "see" sound frequencies, we know that it exist, we can listen them.



Even that we cannot see or hear infrared, we can feel it at our skin temperature sensors. When you approach your hand to fire or warm element, you will "feel" the heat, but you can't see it. You can see the fire because it emits other types of radiation, visible to your eyes, but it also emits lots of infrared that you can only feel in your skin.

### Infrared in Electronics

Infra-Red is interesting, because it is easily generated and doesn't suffer electromagnetic interference, so it is nicely used to communication and control, but it is not perfect, some other light emissions could contains infrared as well, and that can interfere in this communication. The sun is an example, since it emits a wide spectrum or radiation.

The adventure of using lots of infra-red in TV/VCR remote controls and other applications, brought infra-red diodes (emitter and receivers) at very low cost at the market.

From now on you should think as infrared as just a "red" light. This light can means something to the receiver, the "on or off" radiation can transmit different meanings. Lots of things can generate infrared, anything that radiate heat do it, including out body, lamps, stove, oven, friction your hands together, even the hot water at the faucet.

To allow a good communication using infra-red, and avoid those "fake" signals, it is imperative to use a "key" that can tell the receiver what is the real data transmitted and what is fake. As an analogy, looking eye naked to the night sky you can see hundreds of stars, but you can spot easily a far away airplane just by its flashing strobe light. That strobe light is the "key", the "coding" element that alerts us.

## Soil Sensor

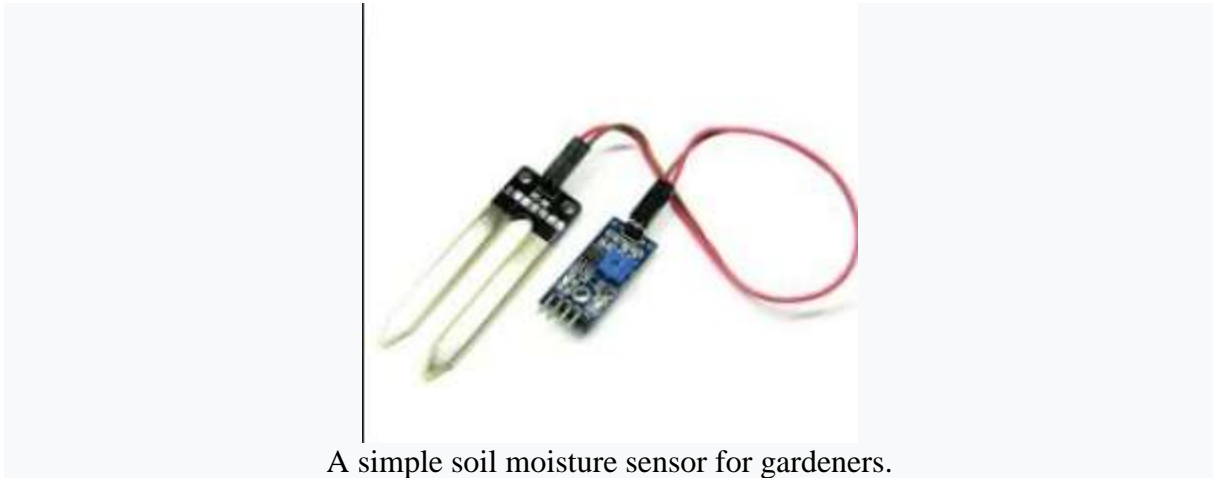

A simple soil moisture sensor for gardeners.

**Soil moisture sensors** measure the volumetric water content in soil.<sup>[1]</sup> Since the direct gravimetric measurement of free soil moisture requires removing, drying, and weighting of a sample, soil moisture sensors measure the volumetric water content indirectly by using some other property of the soil, such as electrical resistance, dielectric constant, or interaction with neutrons, as a proxy for the moisture content.

The relation between the measured property and soil moisture must be calibrated and may vary depending on environmental factors such as soil type, temperature, or electric conductivity. Reflected microwave radiation is affected by the soil moisture and is used for remote sensing in hydrology and agriculture. Portable probe instruments can be used by farmers or gardeners.

Soil moisture sensors typically refer to sensors that estimate volumetric water content. Another class of sensors measure another property of moisture in soils called water potential; these sensors are usually referred to as soil water potential sensors and include tensiometers and gypsum blocks.

## Relays

We know that most of the high end industrial application devices have relays for their effective working. Relays are simple switches which are operated both electrically and mechanically. Relays consist of an electromagnet and also a set of contacts. The switching mechanism is carried out with the help of the electromagnet. There are also other operating principles for its working. But they differ according to their applications. Most of the devices have the application of relays.

The main operation of a relay comes in places where only a low-power signal can be used to control a circuit. It is also used in places where only one signal can be used to control a lot of circuits. The application of relays started during the invention of telephones. They played an important role in switching calls in telephone exchanges. They were also used in long distance telegraphy. They were used to switch the signal coming from one source to another destination.



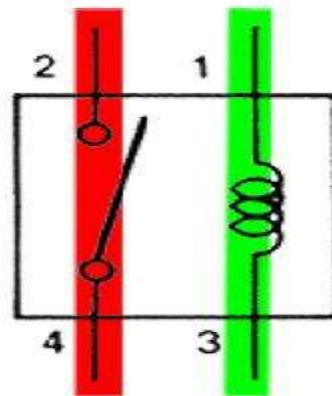

relay operation

### Project Description Block Diagram:

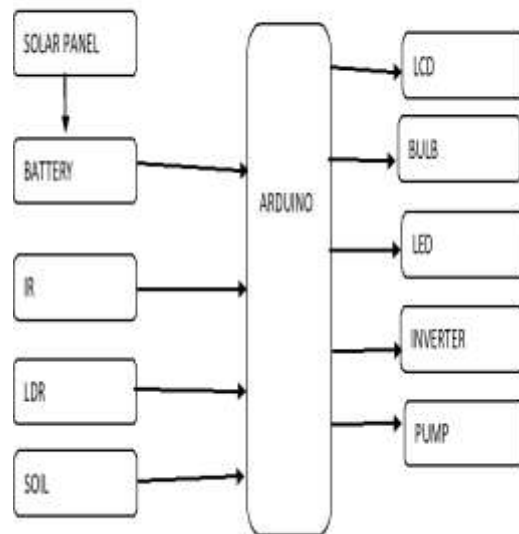

Fig block diagram

### Software Requirements:

- arduino

### Hardware Requirements:

- Transformer
- Diodes
- Capacitors
- Resistors
- LDR
- Transistor
- Microcontroller

**Working:**

Now after knowing what a solar inverter is, let's talk about its working. Solar panels produce direct electricity with the help of electrons that are moving from negative to positive direction. Most of the appliances that we use at home work on alternative current. This AC is created by the constant back and forth of the electrons from negative to positive. In AC electricity the voltage can be adjusted according to the use of the appliance. As solar panels only produce Direct current the solar inverter is used to convert the DC to AC.

An inverter produces square waves or a sine wave which can be used for running lights, televisions, lights, motors etc. However these inverters also produce harmonic distortion. Expensive inverters make use of lots of steps to produce a sine wave and thus are found in residential solar inverters. Basically inverters should be a large one so that it supplies enough power to all the necessary appliances.

An inverter is easy to buy but choosing the right solar inverter for your appliance is more important. Thus you must always consult a solar professional before buying on. We know that the energy derived from sun is solar energy which is one of the cleanest sources of energy. Also it can be used to provide lighting to houses.

You can make use of the photovoltaic tiles that attract energy from Sun and converts it into a clean form of electricity which can be used to light, houses, industries and companies. The cells of photovoltaic consist of positive and negative silicon that is placed underneath a slice of glass. When the protons of the Sunlight hit the PV cells they knock the neutrons present in the silicon. Now the negative charged neutrons get attracted to the silicon but then are held inside a magnetic field. The wires attached on the silicon catch hold of these neutrons and while connecting to the circuit, current is formed. This then gives space for direct electricity and for converting that into alternate electricity an inverter is used so that the house appliances can run. As mentioned before major of the house appliances work on alternate current hence an inverter is used to convert DC to AC.

Solar power apart from making your home appliances work can also be used to heat water and swimming pools too.

Here we were used ldr for automatic on off the lights. SOIL SENSOR FOR TO ON THE PUMP IN THE GARDEN

**4. CONCLUSION**

The designed solar tracker system could track the movement of the sun with the help of microcontroller and stepper motor. This system can work properly irrespective of weather conditions and location. We can change the threshold voltage of the tracker according to our requirement. It can also initialize the starting position once the sun sets. Moreover, during night the solar panel faces the ground which in turn protects it from dust particles and increases its longevity. However, the designed prototype of the solar tracker is a miniature of the main system and so there are a number of limitations. The number of LDRs should be increased for the practical case. Moreover, we have considered one dimensional rotation of the tracker. So we aim to increase the degrees of freedom of this tracker in future course of work.

**5. REFERENCES**

1. Arsalan, S. 2013. Sun Tracking System with Microcontroller 8051, Intl. J. Sci & Eng. Research, Vol. 4, 2998.
2. Anuraj, A.,and Gandhi R., 2014, Solar Tracking System Using Stepper Motor, Intl. J. Electronic & Electrical Eng., Vol.7 , 561
3. Chhatwani, P. K., and Somani, J. S., 2013, Intelligent Solar Tracker System Implemented On 8051 Microcontroller, Intl. J. Eng. Trends Technol., Vol 4, 4267.
4. Saxena, A. K., and Dutta, V., 1990, A versatile microprocessor based controller for solar tracking, Photovolt Specialists Conf., 21st IEEE Proc.
5. Nirmal, H. B., and Naveed, S. A., 2013, Microcontroller Based Automatic Solar Power Tracking System, Intl. J. Electrical Eng. & Technol., Vol 4, 109.
6. Tudorache, T., and Kreindler, L., 2010, Design of a Solar Tracker System for PV Power Plants, Acta Polytech. Hung., Vol 7, 23.
7. Barsoum, N., and Vasant, P., 2010, Simplified Solar Tracking Prototype, Global J. Technol. Optim.,Vol. 1, 38.
8. Wang., J. M., and Lu, C. L., 2013, Design and Implementation of a Sun Tracker with a Dual-Axis Single Motor for an Optical Sensor-Based Photovoltaic System, Sensors, Vol. 13, 3157.
9. Bingoll, O., Altintas, A., and Oner, Y., 2006 Microcontroller Based Solar-tracking System and its Implementation, J. Eng. Sci., Vol. 12, 243.