

# Developing a System for IoT-Based Movement Induction Motor

Namit Gupta, Assistant Professor,  
College of Computing Sciences and Information Technology, Teerthanker Mahaveer University,  
Moradabad, Uttar Pradesh, India  
Email Id- namit.k.gupta@gmail.com

**ABSTRACT:** *Due to its superior qualities as compared to others, induction motors, particularly three-phase induction motors, are often utilized in the industry. One of the newest technologies for improving the efficiency and dependability of motors is distant control converters. The Internet of Things has emerged as one of the primary methods to connect with various gadgets thanks to the rapid growth of technology and the development of the network connection. Internet connectivity has risen, particularly in industrial settings where it improves products monitoring and control. In this investigation, a manufacturing induction motor was analyzed utilizing a wireless TCP/IP interface, and differences from predicted operating conditions prior to an event happening by a motor were identified and estimated. This assists for the least number of disastrous repair and replacement while also preventing clogs in the construction system. In this study, the motorcycle's motor voltages, power flow, and Hall-effect reference voltage were measured. To do this, the established infrastructure evaluates the motor's findings and sends those data to a centralized monitoring system. This work will give details on IoT (Internet of Things)-based motion intelligence monitoring in the coming days, assisting and setting up an alternative route for other researchers' study.*

**KEYWORDS:** *Applications, Hardware, Induction Motor, Internet, IoT, Monitoring System, Software.*

## 1. INTRODUCTION

The traditional definition of computing isn't confined to desktops, laptops, and phones in the modern day. It comprises intelligent products that are now being manufactured and some of which are interconnected through the Internet, including manufacturing, infrastructures, environments, instruments, as well as interconnections for everyday consumer usage. Internet access used to be restricted to user-to-user knowledge exchange, but it is now capable of reshaping society. The instant understanding, applications, and accurate information pertaining to items in the complicated real world are the main goals of the Internet [1]. The Internet of Things (IoT) has reemerged, much beyond the expectations of the average person, as web forms and facilities have expanded. The Internet of Things (IoT) is a global network of intelligent things that fundamentally aims to link the majority of everyday hand materials and tools to the Web to provide luxury and support to the elderly and crippled. The overall goal of the current study is to suggest a system that can lower energy usage while retaining extra motor energy for later use [2].

The Wireless Transmission Control Protocol/Internet Protocol (TCP/IP) protocol was used to analyses a factory Alternating Current (AC) generator in addition to recognizing and measuring deviations from the planned operating mode that result in motor failure. This prevents system software failures and encourages, for instance, the least drastic repair or replacement. This activity

included reading the motor voltage, starting the engine, and outputs linked to the Hall Effect. Your necessary power usage has been revised [3]. This same established model normally evaluates motor data and transmits measures to a unitary type of government to achieve this purpose. With the use of centralized management equipment that operates in real-time, these features may then be further utilized to create forecasts for preventative maintenance programs.

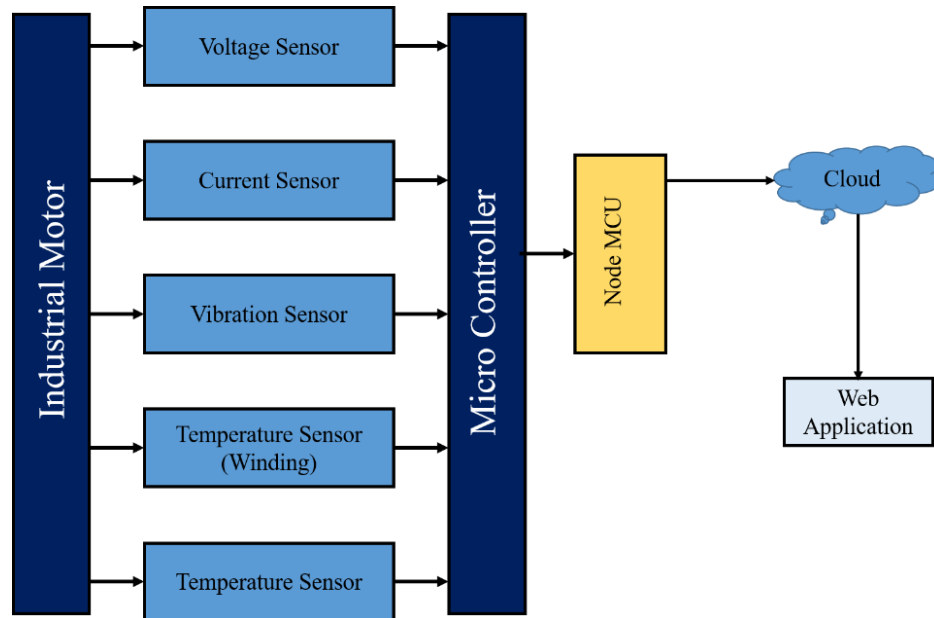
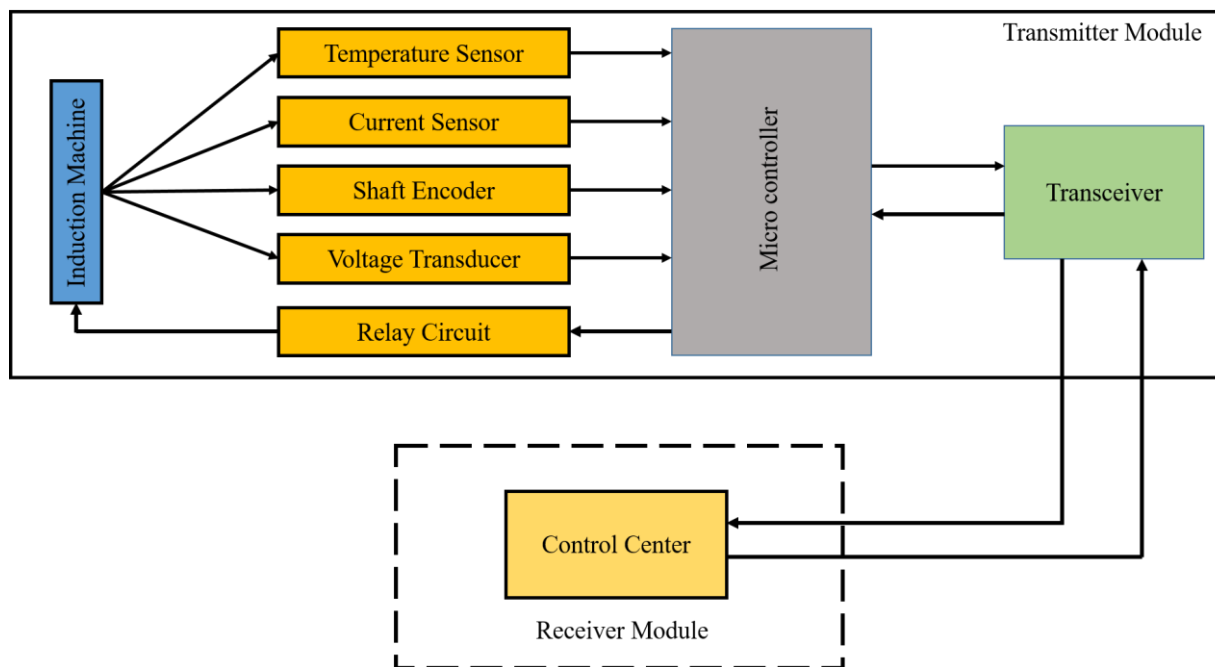

**Figure 1: Representing Block diagram of an Induction Motor Monitoring System.**

### 1.1. IoT Deployment in System Design:

Figure 1 displays the design for an Internet of Things-based industrial motor monitoring system. In line with the specifications, the sensor measures the parameters and transmits the signal to the microcontroller (Arduino-UNO board). Now that this information has been used, the node MCU will show it on the monitor. A network akin to the cloud receives data from the NODE MCU (thing-speak). Hardware, software, or a mix of the two is often used to construct bridges.

IoT supports the central role that is performed in each set of the module, and as far as we know, the field of IoT will continue to expand and evolve over time, serving as the zeitgeist of both the present and future generations. According to the current situation, it can be predicted that the Internet will take over most tasks in the future and will drive mankind forward by meeting needs at a level that is both comfortable and affordable [4]–[6]. The main task is to send data (temperature, light intensity) gathered by the Control unit to a server placed in the middle of the network using USB connection as a means of communication. The sent data is displayed on a PC and may be saved for later use. The system architecture, which is shown in Figure 2, has two distinct modules: the transmitter's module, which sends the data, and the reception subsystem, that is in charge of accepting the instruction and carrying it out as necessary.



**Figure 2: Illustrates the implementation of the IoT in System Design.**

## 2. LITERATURE REVIEW

K. S. Rekha and D. Devi shown that motor drives were still the most popular kind of motor for commercial applications. The induction motor's key benefit is the straight rotor construction, which results in lower costs, greater durability, and less frequent maintenance needs. A researcher has proposed a wirelessly management and monitoring system for an induction motor utilizing the Internet of Things (IoT) for secure and economic data transmission in industrial locations. A module of transducers and sensors regulates the three-phase induction motor's temperature, exterior condensate run-per-speed, vibrations, total current, as well as voltage. The information is then sent to a processing unit for display and analysis. For remote monitoring, the processing unit also interfaces with the gateway module to transfer data to the remote directory. The system may provide automated and manual regulation methods for halting or starting the combustion engine in order to avoid technical fault. It offers an Android app to speed up and improve the use of the platform [4].

A. Choudhary et al. demonstrated how the manufacturing industry is already under intense pressure to reduce unplanned breakdowns, save operating costs, and increase plant availability in the age of globalisation. The development of many implanted devices is ongoing worldwide as a result of the Internet of Things (IoT) movement. A wireless monitoring and management system for the health of induction machines based on the Internet of Things is presented in this study. Three distinct characteristics—voltage, temperature, as well as speed—were tracked by a sensor network and then processed for analysis and presentation by a computer. Additionally, data has been sent to a cloud database using the Ethernet adapter of the microcontroller to enable wireless remote management of an induction machine. The system was designed to improve problem detection and to monitor and maintain numerous parameters in real-time due to the ultra-limiting

of amperage, voltage, temperature, as well as velocity values. The suggested technique has great promise for real-time, cost-effective, and sophisticated equipment health monitoring in industrial settings [7].

### 3. DISCUSSION

With the IoT paradigm, anything becomes an independent item. Authentication, monitoring, communications, as well as processing capacity found in intelligent objects allow users to engage with, among other things, software as well as World Wide Web services. Intelligent items, which are at the heart of the Internet of Things, improve livability in cities [8]–[11]. Different Smart City cities seem to be active with a number of IoT-based applications. In this thesis, we have utilized IoT to solve the issues of irrigation water, traffic flow, and power cost in addition to creating a city a smart city. Three alternative sub module levels have been given by the researcher for an IoT automation project. These parts keep an eye on and control the inverter circuit in order to resolve the following problems.

It has been shown that the proposed system can effectively address a number of issues, including those related to power use, automation, and billing. This work implements a hardware and software platform for a preemptively multitasking movement monitoring system. The hardware component is a sensor-based host browser extension for Universal Serial debugging. The software consists of two major portions that combine data transfer, start/stop detection, action identification, and cycle counting. By developing a micro communication interface and a power supply control unit, the node is built on a currency solution. The technology works well in use and has great economic value due to the hardware needs. Additionally, there are methods for detecting activity as well as approaches for probing and experimentally proven cycle estimate. The Action Recognition Method includes support vector machines, a deep neural network with extended selective memory, and the Internet Corporation for Names and Numbers (LSTM). The quick Fourier transform implementations and over-zero detection are now the foundations of the period computation method. The experimental findings demonstrate the automated inspection system's superiority in activity identification and duration estimation. Due to the nature of the study arrangement and the use of specialized network PCs rather than cloud servers, this was accompanied by much fewer data sources.

### 4. CONCLUSION

Inductive loads are often used in the industry because of their various applications. This is crucial for creating intelligent systems, and a smart panel that attempts to control the load both manually and via the IoT has been created specifically for this. Wi-Fi enables us to utilize a more enjoyable and effective IoT control system from anywhere. It is simpler and quicker to manage than a manual method since no one has to be physically there. In addition to lowering human expenses, this will improve system comprehension. However, manual firms and corporations are furthermore utilized as a safety net. We may simply control the system manually if there is a performance issue that stops the automated way from operating. In addition to these benefits, this smart panel shines in terms of security and control. Any mechanical or electrical breakdown may be fixed with the Internet of Things (IoT) practically anywhere. Electrical problems with a three-phase induction machine, such as under-voltage and overheating, must also be taken into account by MATLAB.

The molded case kill switch is used while working on the settings screen for maintenance or protection. The IoT may be used to enhance this technology in the future to conduct various motor faults, their reversals, and other things, which will be extremely helpful for companies that need to govern things. It happens. Following installation, the isolated expenditure has the necessary quantity and quality to track power use in real time. By keeping an eye on changes in the nonpayer's readings, electrical issues may be found and controlled.

**REFERENCES:**

- [1] A. Glowacz and Z. Glowacz, "Diagnosis of the three-phase induction motor using thermal imaging," *Infrared Phys. Technol.*, 2017, doi: 10.1016/j.infrared.2016.12.003.
- [2] A. Singh, B. Grant, R. Defour, C. Sharma, and S. Bahadoorsingh, "A review of induction motor fault modeling," *Electric Power Systems Research*. 2016. doi: 10.1016/j.epr.2015.12.017.
- [3] A. Glowacz and Z. Glowacz, "Diagnosis of stator faults of the single-phase induction motor using acoustic signals," *Appl. Acoust.*, 2017, doi: 10.1016/j.apacoust.2016.10.012.
- [4] K. S. Rekha and D. S. Ravi, "Induction Motor Condition Monitoring and Controlling Based on IoT," *Int. J. Electron. Electr. Comput. Syst.*, 2017.
- [5] A. F. da Silva, R. L. Ohta, M. N. dos Santos, and A. P. D. Binotto, "A Cloud-based Architecture for the Internet of Things targeting Industrial Devices Remote Monitoring and Control," 2016. doi: 10.1016/j.ifacol.2016.11.137.
- [6] S. S. Goundar, M. R. Pillai, K. A. Mamun, F. R. Islam, and R. Deo, "Real time condition monitoring system for industrial motors," 2016. doi: 10.1109/APWCCSE.2015.7476232.
- [7] A. Choudhary, S. Jamwal, D. Goyal, R. K. Dang, and S. Sehgal, "Condition Monitoring of Induction Motor Using Internet of Things (IoT)," 2020. doi: 10.1007/978-981-15-1071-7\_30.
- [8] R. H. Cunha Palácios, I. N. Da Silva, A. Goedtel, and W. F. Godoy, "A comprehensive evaluation of intelligent classifiers for fault identification in three-phase induction motors," *Electr. Power Syst. Res.*, 2015, doi: 10.1016/j.epr.2015.06.008.
- [9] G. H. Bazan, P. R. Scalassara, W. Endo, A. Goedtel, W. F. Godoy, and R. H. C. Palácios, "Stator fault analysis of three-phase induction motors using information measures and artificial neural networks," *Electr. Power Syst. Res.*, 2017, doi: 10.1016/j.epr.2016.09.031.
- [10] W. S. Gongora, A. Goedtel, S. A. O. Da Silva, and C. L. Graciola, "Neural Approach to Fault Detection in Three-phase Induction Motors," *IEEE Lat. Am. Trans.*, 2016, doi: 10.1109/TLA.2016.7459610.
- [11] A. Glowacz *et al.*, "Fault diagnosis of three phase induction motor using current signal, MSAF-Ratio15 and selected classifiers," *Arch. Metall. Mater.*, 2017, doi: 10.1515/amm-2017-0355.