

A Comprehensive Study on Energy Transmission Technology and Systematic Analysis of Its Balance

Pankaj Kuamr Goswami, Associate Professor,
Department of Electronics and Communication Engineering, Teerthanker Mahaveer University,
Moradabad, Uttar Pradesh, India
Email Id- g.pankaj1@gmail.com

ABSTRACT: *In the modern world, nuclear power production from reactors is becoming more and more important, and the fission process is being used. Large communications projects create concerns about maintaining environmental protection within legislation and management, just as power plants and transportation networks do. In this essay, the author goes into detail on how ecological justice has been discussed in a variety of contexts, with particular emphasis on due process, distributive justice, and credit-related problems. Growing coordination between normative main beliefs and the geographic community sciences has increased interest in the scalar aspect of ecological righteousness, specifically how the framework of preparation and actions at various and incompatible balance fallout within imbalances among local reactance communities, and areas and national executive establishment. Before the advanced nuclear waste is properly buried in the environment, radiochemists are working to recover important long-lasting radionuclides from it. The findings demonstrate that biosorption has been employed by scientists in the past as an alternative to conventional liquid partition methods for the treatment of nuclear waste.*

KEYWORDS: *Biosorption, Energy, Ecological, Nuclear, Reactors.*

1. INTRODUCTION

Nuclear reactors produce energy via the fission process, as is generally known, but there is also some dissipation produced in that situation. Since the beginning of urban nuclear management, the energy produced by nuclear reactors evaporates in a negligible amount and is professionally handled. To create more low-carbon energy, a number of organizational strategies are used, such as direct removal or reuse in reactors. Like all commercial and energy-producing systems, nuclear energy generates a range of wastes. Based on their radioactivity, nuclear materials may be divided into three categories: low-, intermediate-, and high-level. Only 1% of the overall radioactivity is included in the garbage, which is mostly made up of very slightly radioactive goods like tools and work clothes [1]–[4]. Contrarily, advanced nuclear energy that has undergone nuclear reactions and been categorized as garbage makes up just 3% of the overall volume of trash but includes 95% of the radioactivity. Figure 1 embellishes the power generation system.

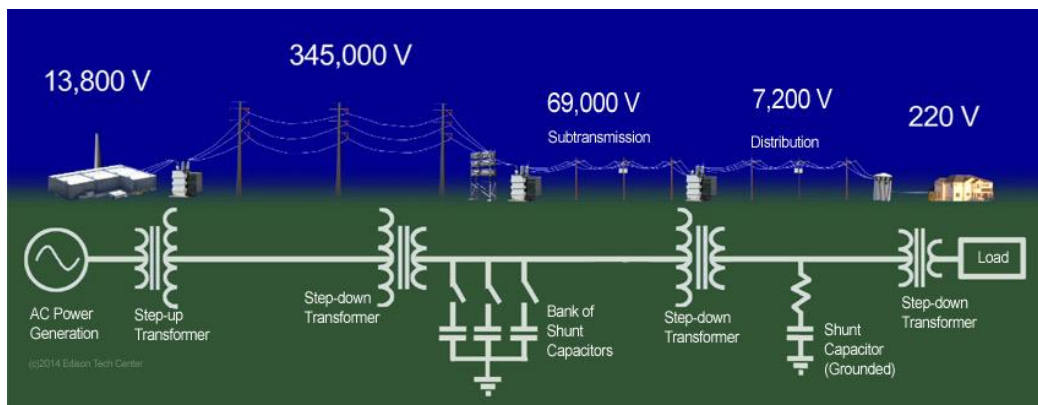

Figure 1: Embellishes the power generation system [5].

The nuclear business is fully accountable for all of its waste, maybe more so than any other energy-producing sector. While facilities for high-level waste and spent nuclear energy are being deployed or developed, there are several permanent disposal facilities for low- and intermediate-level waste that are already in use. Nuclear power plants produce garbage. Due to the impact of E=physics MC2, nuclear dissipation is both very small and extremely damaging. The little quantity of waste is encouraging since its overall impact on the environment, human health, and the ecology may be minimal. However, there must be legitimate worries that the dangers will be harder to manage. Every time an atomic power cell splits in and out of the split in what seems to be a power plant, nuclear light is released. The remaining lighter particle, often referred to as neutrons, contributes significantly to the loss of atomic energy. On the surface, nuclear dissipation seems to be the same process used in bombs, which are often constructed from long metal bars holding electrical pods. However, nuclear fission had changed the components such that they were no longer comparable [6]–[8].

Platonizable particles are often stacked within tubes and combined during power producing bundles to feed nuclear in commercial boilers. Little granules in the tube escape as radionuclides when a particle's electrons split and the radiation is released. The radioactive dissipation has the same shape as the introduced particles and functions similarly to a pitcher. Despite important developments, such as those in the radiological oil and gas sector, there are still a number of issues with regard to how to safely dispose of amassing radioactive waste. Long radioisotopes are produced by mining operations and nuclear power plants and are known to pose a major threat to the environment. Like radioisotope leakage via formations, such as mines, has the potential to taint nearby freshwater sources like streams. These radioisotopes boost transmitters, and digesting them thereafter may result in cancer in rats. A garbage storage company has been set up to address all of these issues. It focuses primarily on using electromagnetic dissipation techniques to recover several long-lived fissionable elements, including significant radioisotopes like uranium and americium.

2. DISCUSSION

It is processed in pottery and glassware before being properly disposed of in stratigraphic reserves. Iron oxides have been eliminated from nuclear effluent using a number of extraction techniques, including as adsorption, liquid-liquid extraction, and electrostatic interactions. Using tributes inorganic phosphate in alcohols like gasoline, ethanol, or dedicate is a common method for actinide separation. Unfortunately, after a few attachment cycles, Construct degrades due to ultraviolet (UV) exposure. Many breakdown mechanisms, such hydrogen

mono-butyl phosphoric acid (H₂MBP) and dibutylphosphoric acid (HDBP), bridge different transition metals, lowering the approach's tolerance. On the other hand, extra measures are required when manufacturing tri butyl phosphate (TBP) and a significant amount of other minimal dietary wastes. Despite the development of several techniques throughout time that centre on chromic and radiolytically robust agonists and ecological solutions such aqueous solutions, the technology is still unsustainable due to weak dissociation coefficients.

Immobilization has only recently been utilised to preconcentrate gases from radioactive dissipate mixtures, as shown by the employment of a range of sorbents, both synthetic and biological, for processing uranium dissipate. Alpha emitters have been distinguished using stable materials as heather, silicate, aluminium, adsorbent, silicates, nanocomposite big particles, extrinsic, nanoparticles, nonmaterial, and nanocomposite. All of those resilient carbon compounds have shown exceptional sensitivity and biocompatibility. When evaluating the adsorption process during isolation's performance potential, cost is a crucial factor to take into account. Organic matter and fouls nanofluid have been the most expensive when segregating, despite being generally available and substantially less expensive than manufactured bio sorbents such solute composites or inorganic. Figure 2 embellishes the wireless power transmission in an effective manner [9]–[13].

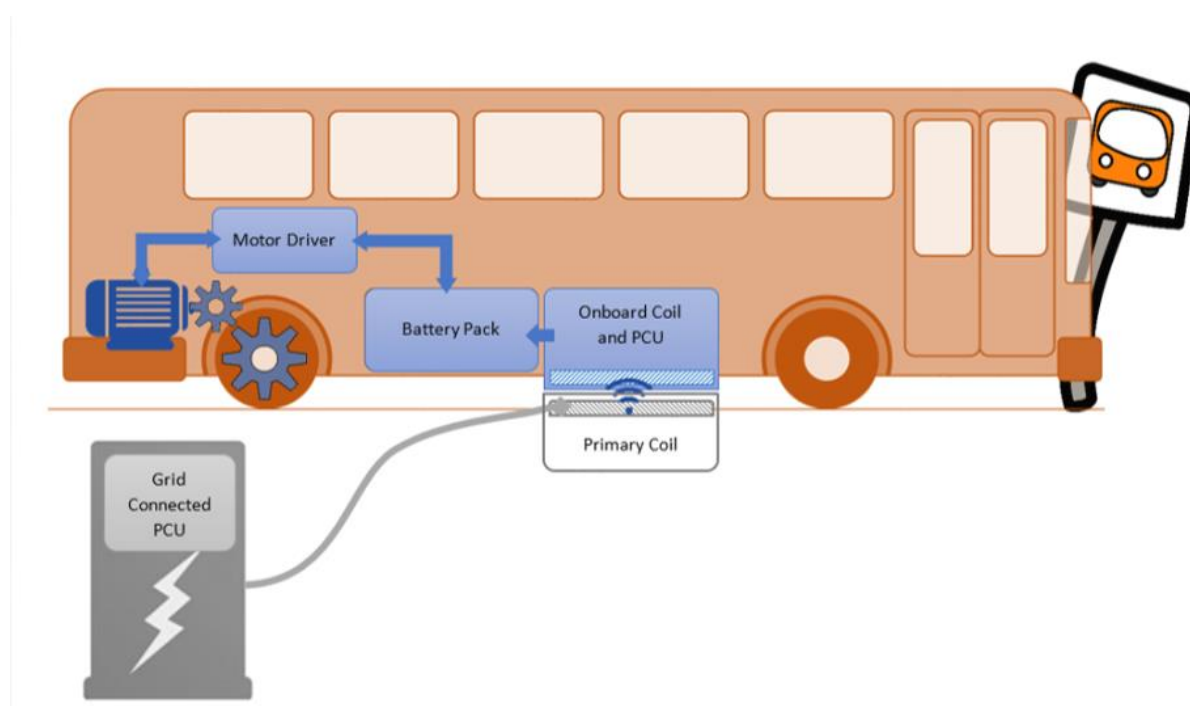

Figure 2: Embellishes the wireless power transmission in an effective manner [14].

Since nuclear material started out as a source of energy but ended up as a significant pollutant, it is required for the execution of atomic power projects. Rising radiation levels in ecoregions are a result of drainage, unrestricted quarrying, and the use of radionuclides for both military and non-military applications. The Department of Health has set the allowed range of nuclear fuel for drinking purposes at 30 g L⁻¹ owing to the harm that nuclear material provides to public health due to its longer and better, wide dispersion, and teratogenic qualities. For the long-term form of new energy projects, uranium removal from Prioritization has only been given to the watershed, plutonium processes, as well as seawater. Uranium has been extracted using organic

solvents, membrane filtering, coagulation-flocculation, and adsorption techniques. Adsorption is seen to be practicable due to its simplicity, high efficiency, and wide applicability of these technologies. The decontamination procedure is more economically viable when bio sorbents are used. The separation of radium from acidity and saltwater mixtures has also been tried in a number of bioreactors made up of fungal, clostridium, algal, plant, and animal sources.

Currently, research is being done to examine how radiometric suspension affects microorganisms, notably nuclear fuel resorption. The biological treatment of nuclear fuel includes changing ionic strength under acidic conditions because protein atoms fight for functional groups. In comparison to previous copyrighted biomasses from microalgae and actinomycetes, one of these samples had a better potential for adsorbents to nuclear fuel. It was discovered that a Clostridium sample isolated on growth medium was a powerful thorium (IV) and uranium (U) accumulator (IV). The process of metal sequestration was unaffected by the presence of carbon dioxide or fossil fuels. The pH range for radionuclide biosorption was found to be 4.0 to 5.0. The behaviour of adsorption isotherms in semisolid biofuels was examined using Langmuir adsorption models. Radioisotopes adsorb to bacteria, according to the Langmuir isotherm, which closely matched the Langmuir model. The same aluminum sequestered location was identified using X-ray spectroscopy and transform electron microscopy (TEM) [15]–[19].

This activity includes initiatives intended to change the properties of dispersed streams to enhance security or profitability. Examples of treatment include compacting to decrease size, separating or exchanging particles to eliminate radioactive material, or using rain to produce physical and chemical changes. The process of putting garbage in a state that is acceptable for secure transit, storage, and disposal is known as conditioning. Dumpster waste is usually made useless at this time. Even though 90% of the wasted radioactive energy is made up of uranium, 90% of it is still usable and may be put into another reactor to be used again. The ability to produce power from radiopharmaceutical can be developed into a comprehensive energy cycle. More than 90% of radioactive energy is uranium. 90% of the energy that is wasted is still being used as a consequence.

It may be chemically treated and put into further reactors to complete the energy cycle. Less radioisotopes and more energy are extracted from the raw ore in a complete energy cycle. You may also turn your concepts into ineffective chemical forms with this technique. In Holland, used diesel fuel is being repurposed once again. While effectively encasing the remaining waste in white cement fibreglass, people use the functionalized boiler components that generate electricity in the facilities. Because it generated enriched uranium, which might be used to create chemical weapons, the United States (US) ceased to recycle using advanced fast reactors.

3. CONCLUSION

This review emphasized the value of severance. Adsorbents of staphylococci, actinomycetes, larval, chemical, and canine origin were used to preconcentrate dangerous f-facets. As a consequence, although being inexpensive and widely available, many bulk biosorptions are useless due to their low absorption rates. The author spoke about how the biosorbent's membrane effectively caught all biotic traits, leading to a notable amplification, particularly in the adsorption process, and positioning it as a major competitor to other industrial sorbents in terms of price ratio for high biocompatibility. The goal of adsorption enhancement is to solve the sorption process' logistical problems. It is possible to evaluate the efficacy of

bioremediation techniques for different process parameters and utilise equations to guide policy research. The author of this study comes to the conclusion that there are various benefits, such as cost-effectiveness, high competence, decreased material natural sludge, and bio sorbent regeneration with metal recovery potential. Countries confront an urgent need to create a cost-effective and biodegradable technology that can accomplish these goals when other traditional approaches fail due to the drive for fast industrial growth paired with a lack of knowledge regarding metal toxicity. Similar atomic waste management is mostly carried out over an extended period of time. Small quantities of rubbish may be easily removed from nearly anywhere. The average subterranean storage period for waste energy is five years before it is moved to new containers. Significant environmental dumping is often regarded as one of the best options for a disposal location and among the most cancer-causing rubbish produced.

REFERENCES:

- [1] C. K. H. C. K. Yahaya, S. F. S. Adnan, M. Kassim, R. A. Rahman, and M. F. Bin Rusdi, "Analysis of wireless power transfer on the inductive coupling resonant," *Indones. J. Electr. Eng. Comput. Sci.*, 2018, doi: 10.11591/ijeecs.v12.i2.pp592-599.
- [2] S. Mizojiri and K. Shimamura, "Wireless power transfer via Subterahertz-wave," *Applied Sciences (Switzerland)*, 2018. doi: 10.3390/app8122653.
- [3] Y. Ra'di *et al.*, "On-site wireless power generation," *IEEE Trans. Antennas Propag.*, 2018, doi: 10.1109/TAP.2018.2835560.
- [4] M. Schormans, V. Valente, and A. Demosthenous, "Practical Inductive Link Design for Biomedical Wireless Power Transfer: A Tutorial," *IEEE Trans. Biomed. Circuits Syst.*, 2018, doi: 10.1109/TBCAS.2018.2846020.
- [5] S. A. Sis and S. Kavut, "A frequency-tuned magnetic resonance-based wireless power transfer system with near-constant efficiency up to 24 cm distance," *Turkish J. Electr. Eng. Comput. Sci.*, 2018, doi: 10.3906/elk-1803-98.
- [6] K. Li, W. Ni, L. Duan, M. Abolhasan, and J. Niu, "Wireless Power Transfer and Data Collection in Wireless Sensor Networks," *IEEE Trans. Veh. Technol.*, 2018, doi: 10.1109/TVT.2017.2772895.
- [7] T. Wang, X. Liu, N. Jin, H. Tang, X. Yang, and M. Ali, "Wireless power transfer for battery powering system," *Electron.*, 2018, doi: 10.3390/electronics7090178.
- [8] W. Zhong and S. Y. Hui, "Reconfigurable Wireless Power Transfer Systems with High Energy Efficiency over Wide Load Range," *IEEE Trans. Power Electron.*, 2018, doi: 10.1109/TPEL.2017.2748161.
- [9] M. M. Rana, W. Xiang, E. Wang, X. Li, and B. J. Choi, "Internet of Things Infrastructure for Wireless Power Transfer Systems," *IEEE Access*, 2018, doi: 10.1109/ACCESS.2018.2795803.
- [10] C. C. Huang and C. L. Lin, "Wireless Power and Bidirectional Data Transfer Scheme for Battery Charger," *IEEE Trans. Power Electron.*, 2018, doi: 10.1109/TPEL.2017.2725940.
- [11] Y. Huang and B. Clerckx, "Waveform Design for Wireless Power Transfer with Limited Feedback," *IEEE Trans. Wirel. Commun.*, 2018, doi: 10.1109/TWC.2017.2767578.
- [12] C. Nataraj, S. Khan, M. H. Habaebi, and A. G. A. Muthalif, "General analysis of resonance coupled wireless power transfer (WPT) using inductive coils," *Teh. Vjesn.*, 2018, doi: 10.17559/TV-20160105041434.
- [13] Y. J. Park *et al.*, "A Triple-Mode Wireless Power-Receiving Unit with 85.5% System Efficiency for A4WP, WPC, and PMA Applications," *IEEE Trans. Power Electron.*, 2018, doi: 10.1109/TPEL.2017.2703153.
- [14] V. De Santis, T. Campi, S. Cruciani, I. Laakso, and M. Feliziani, "Assessment of the induced electric fields in a carbon-fiber electrical vehicle equipped with a wireless power transfer system," *Energies*, 2018, doi: 10.3390/en11030684.
- [15] Q. Zhu, M. Su, Y. Sun, W. Tang, and A. P. Hu, "Field Orientation Based on Current Amplitude and Phase Angle

- Control for Wireless Power Transfer,” *IEEE Trans. Ind. Electron.*, 2018, doi: 10.1109/TIE.2017.2767556.
- [16] H. Fujimoto *et al.*, “Development of Second Generation Wireless In-Wheel Motor with Dynamic Wireless Power Transfer,” *31st Int. Electr. Veh. Symp. Exhib. Int. Electr. Veh. Technol. Conf. 2018*, 2018.
- [17] M. L. Kung and K. H. Lin, “Dual-Band Coil Module with Repeaters for Diverse Wireless Power Transfer Applications,” *IEEE Trans. Microw. Theory Tech.*, 2018, doi: 10.1109/TMTT.2017.2711010.
- [18] H. Zhang, Y. X. Guo, S. P. Gao, and W. Wu, “Wireless Power Transfer Antenna Alignment Using Third Harmonic,” *IEEE Microw. Wirel. Components Lett.*, 2018, doi: 10.1109/LMWC.2018.2832612.
- [19] I. Joe Louis Paul, S. Sasirekha, D. Naveen Kumar D, and P. S. Revanth, “A Working Model for Mobile Charging using Wireless Power Transmission,” *Int. J. Eng. Technol.*, 2018, doi: 10.14419/ijet.v7i3.12.16434.