

RFID BASED SMART SYSTEM FOR STORING DATA

¹K SUDHAKAR, ²K NARASAPPA, ³Dr. B DHANANJAYA

¹Associate Profesor, ²Assistant Professor, ³Profesor,
Department Of ECE

Bheema Institute of Technology and Science, Adoni

ABSTRACT

The main goal of this research is to obtain personal data from a passport holder using RFID technology. The authorised person receives an RFID card for this use. This card has an integrated circuit that modulates and demodulates the broadcast radio frequency signal in order to store and process data. As a result, the data stored on this card is known as the person's passport data.

Passport verification and inspection take a long time. The suggested method expedites the process by giving the authorised person an RFID tag with all of the passport data, including name, number, and nationality, among other aspects. The RFID card reader scans the data when the card is put in front of it, compares it to data that is kept in the system, and displays the passport holder's information if the data matches. This uses a microcontroller from the 8051 family. The display that we utilise is a 16X2 LCD. Another way to get the status from this system is to press the button linked to the microcontroller.

The project may be made much better by using the finger printer module. This addresses the limitations of RFID and provides a high level of system security

1.1 Introduction

RFID (radio frequency identification) is a form of Wireless communication that incorporates the use of electromagnetic or electrostatic coupling in the radio frequency portion of the electromagnetic spectrum to uniquely identify an object, animal or person. Every RFID system consists of three components: a scanning antenna, a transceiver and a transponder. When the scanning antenna and transceiver are combined, they are referred to as an RFID reader or interrogator.

There are two types of RFID readers -- fixed readers and mobile readers. The RFID reader is a network-connected device that can be portable or permanently attached. It uses radio waves to transmit signals that activate the tag. Once activated, the tag sends a wave back to the antenna, where it is translated into data.

The transponder is in the RFID tag itself. The read range for RFID tags varies based on factors including the type of tag, type of reader, RFID frequency and interference in the surrounding environment or from other RFID tags and readers. Tags that have a stronger power source also have a longer read range.

Micro-controller works according to the program written in it. The program is written in such a way, so that the Microcontroller can read and it can store the information received from the parameter

outputs. According to the received information, the Microcontroller generates digitalized information and this digitalized information is fed to the LCD panel.

1.1 Block Diagram

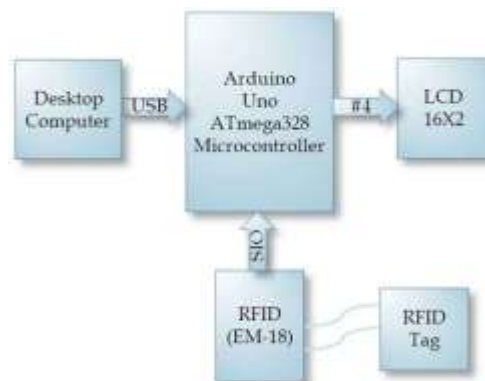

Figure 1. Block Diagram

I. ARDUINO

2.1 Introduction to Arduino

The Arduino UNO is a standard board of Arduino. Here UNO means 'one' in Italian. It was named as UNO to label the first release of Arduino Software. It was also the first USB board released by Arduino. It is considered as the powerful board used in various projects. Arduino.cc developed the Arduino UNO board. The Arduino Uno is an open-source microcontroller board based on the Microchip ATmega328P microcontroller and developed by Arduino.cc and initially released in 2010. The board is equipped with sets of digital and analog input/output (I/O) pins that may be interfaced to various expansion boards (shields) and other circuits.



Figure 2. Arduino UNO Board

It has 14 digital input/output pins (of which 6 can be used as PWM outputs), 6 analog inputs, a 16 MHz ceramic resonator, a USB connection, a power jack, an ICSP header, a reset button. It contains everything needed to support the microcontroller; simply connect it to a computer with a USB cable or power it with a AC-to-DC adapter or battery to get started.

RFIDRC522

The present project work exposes about the technology of smart card reader through wireless communication system. This document is intended to provide a brief introduction to smart card technology, and to describe how a smart card deployment might be handled in an enterprise environment. A smart card is a plastic card in which an integrated circuit, or chip, is embedded. Often microchips are used to store the data of card holder, the size is almost as small as credit card, and Systems using smart cards have multiple point-of-service terminals, or readers, which communicate with the card and with a central host computer system. The development of smart cards is started in 1970, and by end of 2000 advanced technology is implemented, various types of smart cards are developed using micro technology for various applications. The following is the description.

The proposed project work is designed to know the pass port details and its status. This is an innovative technology to get the pass port details through RFID cards. Previously various types of photo identity cards with management seal and signature are in use, now the trend is changed, to increase more safety / security smart cards in the form of Scratch cards, Magnetic cards, etc, are developed, and these

cards became popular. Generally these cards are supposed to be some physical contacts with data readers, in most cases the user inserts his/her card in the smart card reader, the smart card reader is nothing but a data decoder, and the decoded data is fed to a computer. Here the application is quite simple, the user information is stored and it is used for maintaining the record for the attendance purpose, recognition, etc. This kind of systems are existed every where and are common now a days. To implement new trend in the smart ID card technology, this project work is taken up, which provides a wonder full feature of wireless technology to read the data of smart card through Radio Frequency technology.



Figure 3. RFIDRC522

OLED DISPLAY

OLED is an Organic Light-Emitting Diode. OLED Display is a self light-emitting technology composed of a thin, multi-layered organic film placed between an anode and cathode. In contrast to LCD technology, OLED does not require a backlight. We use WEA012864D-03 version 4 pin OLED display module for this project. WEA012864D-03 version 4 pin OLED display module is a diagonal size 0.96 inch COG OLED display with PCB board on it. This WEA012864D-03 version OLED display is made of 128x64 pixels. WEA012864D-03 module is built in with SSD1306BZ IC, it communicates via I2C interface only, VCC 3V /5V, I/O level 5V to 3V, with conversion circuit, 1/64 duty cycle. The WEA012864D-03 model is having a smaller PCB than

WEA012864D-01 version of which outline size is 27.3x27.3x2.37mm with mounting holes on board and 4 metal pins on module.



Fig. 4. OLED Display

LED

A light-emitting diode (LED) is a semiconductor device that emits light when an electric current flows through it. When current passes through an LED, the electrons recombine with holes emitting light in the process. LEDs allow the current to flow in the forward direction and blocks the current in the reverse direction. When the diode is forward biased, the minority electrons are sent from p → n while the minority holes are sent from n → p. At the junction boundary, the concentration of minority carriers increases. [17]

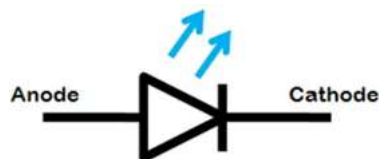

Figure 5. Symbol of LED

II. CIRCUIT DIAGRAM

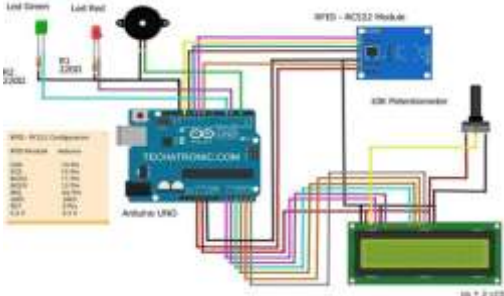

Fig 6 circuit diagram

III. RESULT

RFID Based Gate Access Security System which is able to identify authorized persons and allow only them was successfully developed. The major contribution of this work is managing to write a functional code for Microcontroller to communicate with the RFID devices and store authorized person's data. This system should be able to minimize the technical human error during secured gate access. Besides, the system also helps user to use paperless environment and save the time. Methodology in the project can be defined as a collection of many components which include procedures, techniques, tools and documentation aids that are intended to help the developer in the development. The use of methodology helps to produce a better quality product in terms of documentation standards, acceptability to user, maintainability



Fig 7 RFID PROJECT OUTLOOK



Fig 8: OUTPUT

4.2 Advantages

1. Saving time and money through automation
2. Improving data accuracy and availability
3. Better control of production.
4. Enhanced quality and traceability
5. Increased revenues
6. Tracking assets and managing inventory

4.3 Disadvantages

1. Active RFID is costly due to use of batteries.
2. Privacy is a concern with the use of RFID on products as it can be easily tapped or intercepted.

4.4 Applications

1. Inventory management.
2. Asset tracking and equipment tracking.
3. Inventory control

5 CONCLUSION AND FUTURE SCOPE

Conclusion

Based on this investigation, we were able to determine that Radio Frequency Identification (RFID) is a highly sophisticated automated attendance system that offers more faster and more accurate results than a standard paper-based method. And we boldly declare that, without a doubt, RFID is the greatest way to replace existing methods. Furthermore, we might draw the conclusion that, in order to reduce cheating and raise dependability, it is still necessary to validate the second verification technique, even when using RFID.

We eventually discovered from our investigation that every system we covered had pros and cons of its own.

Certain traits work well in certain systems while others don't. A hybrid approach is required to get around this, yet it only offers a more efficient system with no Based on this investigation, we were able to determine that Radio Frequency Identification (RFID) is a highly sophisticated automated attendance system that offers more faster and more accurate results than a standard paper-based method.

And we boldly declare that, without a doubt, RFID is the greatest way to replace existing methods. Furthermore, we might draw the conclusion that, in order to reduce cheating and raise dependability, it is still necessary to validate the second verification technique, even when using RFID. We eventually discovered from our investigation that every system we covered had pros and cons of its own.

A hybrid approach is required to get around this, yet it only offers a more efficient system with noBased on this investigation, we were able to determine that Radio Frequency Identification (RFID) is a highly sophisticated automated attendance system that offers more faster and more accurate results than a standard paper-based method. And we boldly declare that, without a doubt, RFID is the greatest way to replace existing methods. Furthermore, we may draw the conclusion that, in order to reduce cheating and raise dependability, it is still necessary to validate the second verification method—even when using RFID. For demonstration purposes, the system currently only uses two RFID tags or cards. A certain amount of cards may be provided, and they may also get information on the passport and its status, depending on the requirements.

FUTURE SCOPE

RFID technology is starting to support Internet of Things applications more and more, and it may soon be combined with smart sensors to allow systems to monitor wirelessly transmitted variables like temperature, position, and movement.

REFERENCES

- [1] The following are the references made during the development of this project work.
- [2] Text Books:
- [3] Linear Integrated Circuits By: D. Roy Choudhury, Shail Jain
- [4] Digital Electronics. By JOSEPH J.CARR
- [5] Fundamental of Radio Communication: By A.SHEINGOLD
- [6] Digital and Analog Communication System By: K. sam Shanmugam
- [7] The concepts and Features of Micro-controllers – By: Raj Kamal
- [8] The 8051 Micro-controller Architecture,

IJFANS INTERNATIONAL JOURNAL OF FOOD AND NUTRITIONAL SCIENCES

ISSN PRINT 2319 1775 Online 2320 7876

Research Paper © 2012 IJFANS. All Rights Reserved. UGC CARE Listed (Group -I) Journal Volume 11, Iss 08, 2022

programming & Applications – By: Kenneth J.
Ayala

[9] Programming and Customizing the 8051 Micro-
controller – By: My