

Voice Controlled Robotic Vehicle

N. Varalakshmi¹, A. Haseena²

^{1,2}Assistant Professor, Department Of ECE, CVRT Engineering college, Tadipatri

ABSTRACT

This project work is designed to control a robotic vehicle through voice commands forwarded through smart phone using android application. The wireless communication link established between the android app and the vehicle is facilitated with Bluetooth technology. The main motive to build this voice controlled robotic vehicle is to analyze the human voice and act according to the predefined programmed commands. The most basic commands included here are forward, backward, right turn, left turn and stop. The vehicle will be controlled wirelessly with the use of android smart phone technology and it is very simple also economy point of view, it is very feasible or affordable.

The main processing unit will be constructed using Arduino Uno development board and with the help of a Bluetooth device interfaced with this processor, received commands will be digitalized. The moving mechanism will be constructed using 2 DC motors and these 2 motors are driven independently through motor driving circuit designed with H Bridge IC. The commands delivered from the android application through phone Microphone are converted in to digital signals by the Bluetooth RF transmitter & the range is defined as 50feets approximately.

1. INTRODUCTION

1.1 Introduction

The project work described in the abstract is intended to make a robot vehicle which can be controlled by the voice command of a person. Normally these types of systems are called as Speech Controlled Automation System (SCAS). In this field sophisticated robots are in use for multiple applications, but since it is a prototype module, here a simple robotic vehicle will be constructed to prove the basic concept of voice controlled machine technology. The idea of making this small device is to implement control action in a machine driven by voice commands. The robot is remotely controlled by a mobile phone and there are many topics based on the voice controlled devices establish a communication link between a mechanism and smart phone.

Smart phone is a very good interface for remotely operating the robot. It contains many features that can be helpful. In this design, an android application is used for the required task. The connection between the application and the robot facilitates the control task using Bluetooth technology. The commands issued will be relayed over through the channel and will be received by the module. The objective of voice controlled robotic vehicle (VCRV) is to listen and act on the commands of the user. Here the system requires accent training by which the device will start understanding the voice commands and the commands have been added by codes.

The main motive to build a VCRV is to analyze the human voice and act according to the programmed commands. The most basic voice commands are backward, forward, right, left, and stop. The vehicle is to be controlled wirelessly with the use of android smart phone. The goal of this project work is to make a robotic vehicle with use of advanced smart phone

technology in a very simple and economic way. In current scenario vehicles are manually controlled and all are done by the person who is driving the vehicle. But in nearby future voice controlled real time vehicles may dominate the conventional vehicles in which every action like start, stop, speed, acceleration, applying brake, gear transmission, lighting system control, wiper on, wiper off, etc, every action related to the automobiles can be done using voice control technology.

Nowadays new technologies have been developed for all dangerous tasks, intelligent logic circuits can perform the task better than the people. Even though these robots are being controlled manually in the early stages, these can now be controlled via voice and gestures. This technology of voice recognition can be defined by the interaction between the computer and the voice of human beings.

This constructs the communication link between technology and mankind. The target of this work is to upgrade the complete security to the robot and to simplify the controlling mechanism. The voice directions are handled, utilizing an advanced mobile phone. The viability of the voice control conveyed over a separation is estimated through numerous examinations.

The past decade has seen significant advancement in the field of consumer electronics. Various 'intelligent' appliances such as cellular phones, air-conditioners, home security devices, home theatres, etc. are set to realize the concept of a smart home.

1.2 Block Diagram

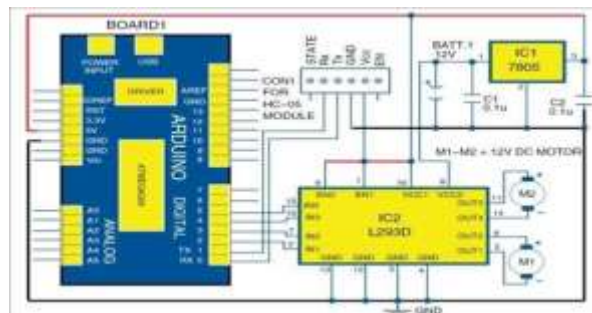

Figure: Block Diagram of Voice Controlled Robotic Vehicle using Smart Phone

1. The Arduino is the heart of the system, here an Arduino UNO R3 is used in this project, It is used for processing the data and provides necessary actions needed.
2. 3-Terminal 1A Positive Voltage Regulator which is making them useful in a wide range of applications.
3. There are two dual channel L293D motor driver to drive the motors for the conveyor belt.

2. DESIGN OF HARDWARE

This chapter briefly explains about the Hardware. It discusses the circuit diagram of each module in detail.

Arduino UNO

The Arduino Uno is a microcontroller board based on the ATmega328 (datasheet). It has 14 digital input/output pins (of which 6 can be used as PWM outputs), 6 analog inputs, a 16 MHz ceramic resonator, a USB connection, a power jack, an ICSP header, and a reset button.

It contains everything needed to support the microcontroller; simply connect it to a computer with a USB cable or power it with a AC-to-DC adapter or battery to get started.

The Uno differs from all preceding boards in that it does not use the FTDI USB-to-serial driver chip. Instead, it features the Atmega16U2 (Atmega8U2 up to version R2) programmed as a USB-to-serial converter. Uno board has a resistor pulling the 8U2 HWB line to ground, making it easier to put into DFU mode. Arduino board has the following new features:

- 1.0 pin out: added SDA and SCL pins that are near to the AREF pin and two other new pins placed near to the RESET pin, the IOREF that allow the shields to adapt to the voltage provided from the board. In future, shields will be compatible both with the board that use the AVR, which operate with 5V and with the Arduino Due that operate with 3.3V. The second one is a not connected pin, that is reserved for future purposes.
- Stronger RESET circuit.
- Atmega 16U2 replace the 8U2.

"Uno" means one in Italian and is named to mark the upcoming release of Arduino 1.0. The Uno and version 1.0 will be the reference versions of Arduino, moving forward. The Uno is the latest in a series of USB Arduino boards, and the reference model for the Arduino platform; for a comparison with previous versions, see the index of Arduino boards.



Fig: Arduino Uno

Power supply:

The power supplies are designed to convert high voltage AC mains electricity to a suitable low voltage supply for electronic circuits and other devices. A power supply can be broken down into a series of blocks, each of which performs a particular function. A d.c power supply which maintains the output voltage constant irrespective of a.c mains fluctuations or load variations is known as “Regulated D.C Power Supply”.

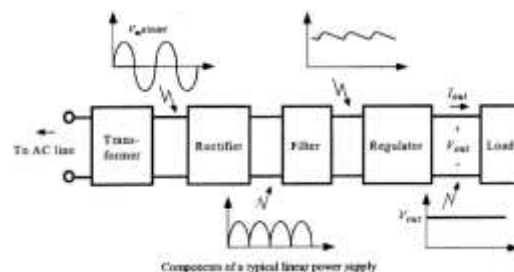

Fig: Block Diagram of Power Supply

HC 05 BLUETOOTH MODULE

This project work consists of two main modules: the android mobile phone and the micro controller with BT board (Bluetooth module). The android mobile phone consists of several Bluetooth apps which enable the user to access the devices by which any device whether it is an electronic circuit or electric machine can be controlled through the android app. The Bluetooth device makes it possible for us to control robot remotely, while smart phone makes it possible for us to control the robot in the visual interface. The android platform includes support for the Bluetooth network stack, which allows a device to wirelessly exchange data with other Bluetooth devices.

The application framework provides access to the Bluetooth functionality through the android Bluetooth APIs. In recent years, the blue-tooth app has become cheap and it is easy to carry and operate and it has more applications in field. Bluetooth uses a low-power signal with a maximum range of 50 feet with sufficient speed to enable transmission of data between mobile and the vehicle.

L293D:

The L293 and L293D are quadruple high-current half-H drivers. The L293 is designed to provide bidirectional drive currents of up to 1 A at voltages from 4.5 V to 36 V. The L293D is designed to provide bidirectional drive currents of up to 600-mA at voltages from 4.5 V to 36 V. Both devices are designed to drive inductive loads such as relays, solenoids, dc and bipolar stepping motors, as well as other high-current/high-voltage loads in positive-supply applications. All inputs are TTL compatible. Each output is a complete totem-pole drive circuit, with a Darlington transistor sink and a pseudo-Darlington source. Drivers are enabled in pairs, with drivers 1 and 2 enabled by 1,2EN and drivers 3 and 4 enabled by 3,4EN. When an enable input is high, the associated drivers are enabled, and their outputs are active and in phase with their inputs. When the enable input is low, those drivers are disabled, and their outputs are off and in the high-impedance state. With the proper data inputs, each pair of drivers forms a full-H (or bridge) reversible drive suitable for solenoid or motor applications.

DC Motor

A DC motor is designed to run on DC electric power. Two examples of pure DC designs are Michael Faraday's homopolar motor (which is uncommon), and the ball bearing motor, which is (so far) a novelty. By far the most common DC motor types are the brushed and brushless types, which use internal and external commutation respectively to create an oscillating AC current from the DC source -- so they are not purely DC machines in a strict sense.

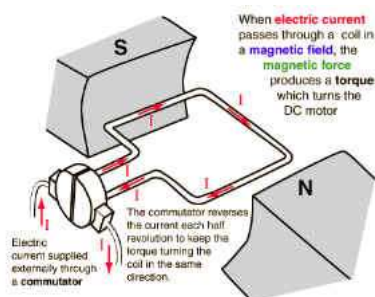

3. CIRCUIT CONNECTIONS AND RESULT

Circuit Diagram

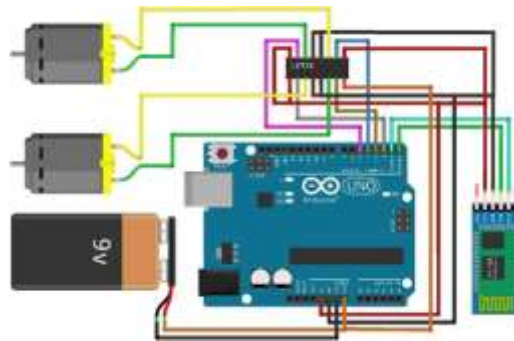

Figure : Circuit Diagram

The controlling device may be any android based Smartphone/tab etc having an android OS. The android controlling system provides a good interactive GUI that makes it easy for the user to control the vehicle. The transmitter uses an android application required for transmitting the data. The receiver end reads these commands and interprets them into controlling the robotic vehicle. The android device sends commands to move the vehicle in forward, backward, right and left directions. After receiving the commands, the Arduino then operates the motors in order to move the vehicle in four directions. The communication between android device and receiver is sent as serial communication data. The Arduino program is designed to move the motor through a motor driver IC as per the commands sent by android device.

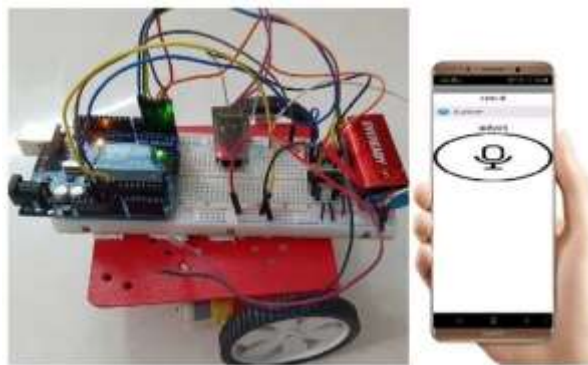

Figure : voice controlled robotic vehicle

Advantages

1. It is easy to use.
2. It work on simple voice command.
3. The size of this robot is small.
4. It is user friendly.
5. It reduce man power.
6. Low power consumption.
7. Reliable, low cost.
8. Accident can be also avoided by using this robot.

Applications

1. The robot is useful in places where humans find difficult to reach but human voice reach. Such as in fire situations, in highly toxic areas.
2. The robot can be used for monitoring or investigation.
3. The voice controlled robotic car can be easily drive by unskilled driver by using voice commands with the help of android application in smart phone.

4. CONCLUSION AND FUTURE SCOPE

Conclusion

The voice controlled robot is an easy programmable (software) project. This project operated on human voice command with android application. The implementation of this project is easy, so this robot is beneficial for human life. The Voice Control Robot is useful for disable people and monitoring purpose. It works on simple voice command, so it is easy to use. It is useful for those areas where humans can't reach. We can implement web cam in this robot for security purpose. The voice recognition software has an accuracy of 76% for identify a voice command and it is also highly sensitive to the surrounding noise.

Future Scope

Useful for speech recognition security system.

1. Useful for military purpose.
2. Automatic target system can be implemented.
3. This robot is useful for those areas where humans can't reach like fire situation, highly toxic areas etc.
4. If we use other technologies like Zigbee or GPS, we can improve the range of the robot.
5. The robot is useful for surveillance.

5. REFERENCES

1. Arduino based voice controlled robot – IEEE Xplore - by A Chaudhry – 2019 Cited by 3 — In this research paper, a system is being proposed, which focuses on the concept of how a robot can be controlled by the human voice. Date Added to IEEE Xplore: 30 January 2020 DOI: 10.1109/ICCCIS48478.2019.8974532 Date of Conference: 18-19 Oct. 2019
2. <https://www.javatpoint.com/arduino-uno>
3. <https://www.farnell.com/datasheets/1682209.pdf>
4. <https://docs.arduino.cc/resources/datasheets/A000066-datasheet.pdf>
5. <http://www.handsontec.com/dataspecs/L298N%20Motor%20Driver.pdf>
6. <https://lastminuteengineers.com/l298n-dc-stepper-driver-arduino-tutorial/>
7. <https://www.google.com/search?q=arduino+uno&oq=arduino+uno&aqs=chrome.0.69i59.3565j0j1&sourceid=chrome&ie=UTF-8>
8. <https://www.maxbotix.com/articles/how-ultrasonic-sensors-work.htm>
9. <https://www.cuidevices.com/blog/the-basics-of-ultrasonic-sensors>
10. <https://www.google.com/search?q=ultrasonic+sensor&oq=ultrasonic+sensor&aqs=chrome..69i57j69i59l2.10036j0j1&sourceid=chrome&ie=UTF-8>
11. <https://islproducts.com/design-note/dc-motor-dc-gear-motor-basics/>
12. <https://www.engineersgarage.com/insight-how-gear-dc-motor-works/>
13. <https://www.engineersgarage.com/insight-how-gear-dc-motor-works/>

14. <https://www.powerelectric.com/motor-resources/motors101/what-are-gear-motors-used-for>
15. <https://www.esa-automation.com/en/gearmotors-types-and-industrial-applicationsgearmotors-types-and-industrial-applications/>
16. <https://www.instructables.com/Tutorial-for-MD-L298-Motor-Driver-Module/>
17. <https://components101.com/misc/buzzer-pinout-working-datasheet>
18. <https://www.pcboard.ca/leds-and-led-ribbon/leds/5mm-leds/5mm-super-bright-red.html>
19. <https://www.make-it.ca/5mm-led-specifications/>
20. <https://web.archive.org/web/20220814210801/https://blog.tentree.com/10-benefits-of-cleaning-up-your-local-beach/>
21. <https://theoceancleanup.com/rivers/>