

# Special Electronic Power Transformer: A Review

Neeraj Kaushik, Assistant Professor,  
Department of Electronics and Communication Engineering, Teerthanker Mahaveer University, Moradabad, Uttar Pradesh, India  
Email Id- neeraj1604@gmail.com

**ABSTRACT:** Usually practice, three-stage AC power supplies aren't the best choice for utility applications. Indeed, three-stage to single-stage, three-stage to double-stage, and three-stage to multiphase transformers are in use all over the world, and they are virtually all manufactured using the same techniques. Despite their enormous size and weight, such transformers have additional deadly characteristics, like as the ability to propagate a deficient current. For a long time, an Electronic Power Transformer, also known as a Power Electronic Transformer or a Solid Transformer, has been suggested. To construct a progression of capacity SEPT extraordinary EPT, we use a module made up of a three-stage Pulse Width Modulation rectifier, a medium recurrence transformer, and yield single-stage inverters in this work. In this article, we also discussed the SEPTs' adjustment methods, as well as extending the PARK change to four stages and proposing the change coefficients of the four-stage AC framework to the dq0 framework straight away. In this article, a few instances are investigated, and the replication results show that SEPT has all of the advantages of EPT, such as more consistent state, better waveforms, better force factor, and so on, when compared to ordinary transformers.

**KEYWORDS:** Special Transformer, Electronic Power Transformer, Four-phase to three-phase, three phase to multiphase, Power quality.

## INTRODUCTION

Individuals often use transformers with power transmission for a long time, ever since Nikole Tesla invented them in the nineteenth century. Voltage change, disengagement, and clamor decoupling are all common uses for transformers in force frameworks. Disengagement here refers to the separation of several voltage positions. Because the transformers allow any AC waves to pass through them, they can't stop music, and they can't block short-circuit current, which may lead to additional problems. When there is an overload, they are unable to halt the voltage drop on the auxiliary side, which may result in a wide range of music contaminating the whole force framework. Similarly, those unusual transformers that are made in an overall manner are bound to transmit unevenness and nonlinear burdens, and that lopsidedness, nonlinear caused by the heaps, will eventually cause criticism to the force framework from the auxiliary side to the essential side and the other way around [1].

Despite the fact that there are currently a few techniques for improving the display of those transformers, exceptional transformers are still used in a variety of activities. As we all know, most fast railroad systems throughout the world used a single-stage source from a specific substation as a force supply for trains, switching from a three-stage source to a single-stage or double-stage source. Because of the activity and running characteristics of the trains, there may be a lot of music input to the power supply system through the substation's extraordinary transformers, and the voltage shift of the power system will also affect the running trains [2]. There have been many

different kinds of gear in operation in multiple specific substations for Chinese railways to enhance the nature of the force supplied to the trains. Because of their hypostasis, these kinds of gear are still unable to resolve problems effectively (Figure 1).

There are various single-stage loads, such as electric heaters, in many facilities, such as a steel-production facility. In most cases, they have a transformer's limit in their own comparable assessment. As a result, they'd make a lot of noise, similar to distorted voltage and flow input to the force network. Three-stage to four-stage transformers have recently attracted a large number of buyers for the advancement of four-stage power transmission frameworks as well as the AT (autotransformer) controlling framework in electric railways. Both of them need a stable and clean power source. Another kind of power transformer is the electronic power transformer (EPT), which is used in both transmission and circulation systems. Numerous publications have focused on the geography and functioning characteristics of EPT. In this article, we try to apply the remarkable nature of EPT to unique transformers [3].

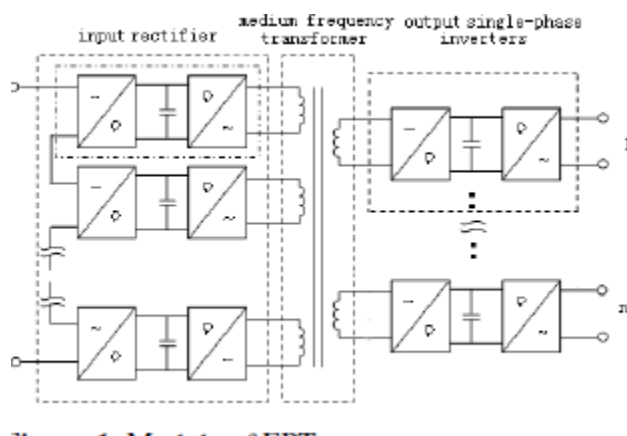

**Figure 1: Module of EPT**

### *Mechanical Stresses and Damage to Transformer*

Mechanical damage to a transformer may be caused by two causes. The strong electromagnetic force produced by huge currents flowing in the transformer windings is one example. Internal faults in transformers or external faults in the network where the transformer is situated may cause such currents. Such circumstances produce large EMFs in a short period of time, which are sufficient to distort or destroy the windings mechanically. This demonstrates that the magnitudes of EMFs on the winding during short circuits are considerably greater than those at normal current, and that such pressures may cause damage to the windings. Axial winding displacement owing to axial forces; buckling of windings due to radial forces; and bending or tilting of windings due to axial forces are all examples of mechanical failures that may occur in transformer windings as a result of large short-circuit fault currents.

Because the transformer's low voltage windings are close to the core and are covered, only the high voltage windings are impacted, and therefore are the primary items to be examined. Axial displacement is the most concerning of the above-mentioned potential failures. Because of their small size and the presence of complete insulation in gaps between the HV and LV windings,

buckling and bending of the HV windings is less probable. A transformer may be damaged during shipment and/or installation. Any damage to the transformer in such a scenario may create lengthy delays in replacement or repair. The impact recorder has to be used throughout the transformer's shipment because of this.

Several transformer damage instances have been documented as a result of poor handling during transit, according to studies. Displacement of the core limb, bent clamping rods, and burst clamping frames are all possible damages. As a result, in addition to any manufacturing flaws, transformers may be damaged during shipping, handling, installation, and servicing. As a result, checking the transformers at each step is critical to prevent failures. As a result, the transformer should be checked on a regular basis and its condition evaluated using appropriate methods[4].

### *Basics of Frequency Response Analysis*

Thermal monitoring, partial discharge measurements, dissolved gas analyses, tan and capacitance measurements, and other methods are available for assessing the transformer's condition. Each of these techniques, however, is used to identify a particular kind of issue, and none of them is appropriate for identifying winding displacement or deformation. Furthermore, traditional diagnostic procedures such as measures of turns ratio, winding impedance/inductance, or the magnetizing current, among others, are difficult to identify winding deformations in transformers. Short circuit reactance measurement, low voltage impulse measurement, and frequency response analysis are the three primary techniques for detecting winding deformation or displacement.

A transformer is a complicated network of RLC components due to the resistance of the winding, inductance of the winding coils, and capacitance of the insulation layers between coils, windings, core and tank, and tank and winding, among other things. This RLC network will be disrupted if the transformer sustains physical damage. By analyzing the frequency response of the transformer, the FRA technique is utilized to detect these tiny changes in the RLC network characteristics inside the transformer. The network transfer function is usually provided via frequency response at different frequencies[5]. In general, the frequency response technique used at the terminals of transformer windings may detect changes caused by winding movement or deformation from the outside.

To extract the FRA signatures, a low voltage signal of various frequencies is delivered to the transformer winding, and both the input and output signals are recorded. The transfer function is the ratio of these two signals, from which the amplitude and phase angle changes with frequency may be calculated. The effective impedance of the transformer's RLC network is measured by the transfer function at each frequency. Over a broad frequency range, the FRA technique may be used to measure the transfer function, evaluate the frequency response characteristics, and diagnose the winding condition[6].

### *New Diagnostic Methods to Support Frequency Response Analysis*

The FRA technique has been tried to improve and refine by a number of researchers, and this section covers some of their attempts.

### *Impedance Analysis*

The understanding of FRA signatures has to be improved. A diagnostic technique based on waveform comparison and statistical coefficient interpretation, which is nevertheless dependent on a type of non-physical analysis. Because one of the most significant characteristics, the winding series capacitance, cannot be accurately measured in transformer bulk, a physical FRA interpretation based on study of physical electrical parameters has not been possible until now, according to the research.

A novel measurement-based technique called as the impedance method is suggested to estimate electrical characteristics of power transformers for the purposes of failure diagnostics and FRA interpretation in the low and mid frequency range. The following are the major uses of this method:

- Calculation of transformer electrical characteristics such as core section frequency-dependent impedances, leakage, zero-sequence pathways, and winding capacitances;
- Interpretation of various standard and nonstandard frequency responses in the low and mid frequency ranges, i.e., voltage ratios and input impedances, respectively.

Because winding mechanical problems are linked with variations in leakage inductance and various capacitances, investigations indicate that the FRA technique alone is ineffective in detecting any detail of the failures (ground, series, and inter-winding HV-LV). Measurements to identify failure type and level in impedance methods may be used to estimate per-phase leakage inductances independently and reliably [7].

## 2. REVIEW OF THE LITERATURE

The Research on Special Electronic Power Transformer Change" explains various events make use of extraordinary transformers. As we all know, most rapid railroad systems throughout the world used a single-stage source from a specific substation as a force supply for trains, switching from a three-stage source to a single-stage or double-stage source. Because of the activity and running characteristics of the trains, there may be a significant amount of music input to the power supply system through the substation's exceptional transformers, and the voltage shift of the power system will also affect the running trains. A large number of pay supplies have been active in a number of specific substations for Chinese railways in order to enhance the character of the force supplied to the trains. Because of their hypostasis, those supplies are nevertheless unable to resolve the problems. There are various single-stage loads, such as electric heaters, in many facilities, such as a steel-production facility. In most cases, they have a transformer's limit in their own comparable assessment. As a result, they'd produce a lot of sound, similar to how twisted voltage and current criticism affects the force matrix. Three-stage to four-stage transformers have recently attracted a large number of buyers for the advancement of four-stage power transmission frameworks, as well as the AT (auto transformer) controlling framework in electric railways. Both of them need a stable and clean power source[8].

*Fuzzy tools*

It has been reported on the use of a fuzzy-logic algorithm for the automated analysis of frequency response measurements of power transformers. FLA analyzes the curve produced by subtracting the current and reference frequency-response across three distinct frequency ranges, each of which is related with a different defect type, such as short circuit between turns, radial, and axial displacements. These frequency ranges were chosen based on mostly SFRA testing findings on transformers with well-known operating characteristics. The FLA method was used to account for the uncertainty in identifying the various faults in these three frequency bands. Distinct fault categories are discovered by “de-fuzzyfication” into different predicates using this method. Each predicate is linked to a particular flaw and has a membership function that determines the output's confidence level. By utilizing suitable membership functions to accommodate for uncertainty, the users are given versatile tools to aid in the assessment of transformer conditions. The algorithm is capable of distinguishing between excellent circumstances and various kinds and degrees of winding defects, according to the validation tests. Furthermore, the method seems to be independent of the transformer testing connection type and appears to be less susceptible to background noise or minor variations. As a result, it is claimed that combining SFRA with the proposed algorithm is a significant step forward in the development of dependable power transformer diagnostics[9].

### *Digital image processing*

The goal of digital image processing is to make it easier to understand visual information on electronic devices. A digital picture is represented by a two-dimensional matrix with a dimension of X Y and a limited number of pixels. Any point on the polar plot with a value of  $|a|$  indicates picture intensity at the point with spatial position. The first step is to get a picture of the FRA polar plot. To simplify the automated capture of the polar plot, this method may be incorporated into any frequency response analyzer. The goal of picture pre-processing is to resize the image, modify the color format, and change the extension type to make it easier to sense in electronic systems. A number of case studies were conducted.

To automate and standardize the process of defect detection and quantification, digital image processing methods based on geometric dimension, texture analysis, and invariant moment features extraction approaches were employed. The FRA polar plot signature, in combination with the established digital image processing (DIP) method, can detect and quantify short circuit defects inside transformer windings, according to both practical and simulated findings. To standardize the FRA interpretation process, suggest that the suggested method is simple, quick, and straightforward to apply inside existing frequency response analyzers[10].

## 3. DISCUSSION

Diagnostics of the power transformer is important for maintenance and keeping the transformer in service. FRA is a useful method for detecting some of internal faults in the transformer. FRA method is quite sensitive for diagnosing some of the internal faults in power transformer. The simulation of several faults such as short circuits, loss of clamps, inter-disk fault, and axial displacement show that such faults can be detected by the FRA technique. Also, the FRA is a

useful technique for detecting the dielectric material in the transformer bushing and its associated fault. The test equipment and the test configuration have an effect on the FRA results and the test leads can also influence the results as well.

Thus several points should be taken into account during the FRA measurements to draw clear conclusions from the measurements performed. The impedance method determines lumped electrical parameters and supports the standard FRA assessment for diagnostics of real mechanical failures. Since the deviations in FRA comparisons can change from transformer to transformer, it is not easy to detect failure type and failure level based on waveform identification alone. In such cases, the changes of electrical parameters can provide helpful additional information. Thus, the combination of FRA and “impedance” method can improve diagnostics of winding mechanical failures. The researchers have reported successful use of fuzzy logic, statistical tools, and image processing and polar diagrams to improve the diagnostic accuracy of FRA methods.

#### 4. CONCLUSION

Contrasted and other force supply utilized in same reason, SEPT has the favorable position in size, weight, productivity and unwavering quality, and has no climate contamination. SEPT can ensure that the essential side of it has excellent waveform and can guarantee the power factor be 1. At the point when the force supply is misshaped and unequal, SEPT can guarantee great waveform provided to the heap, and furthermore, when the heap has some symphonious waves, SEPT can likewise demonstrate the power factor of the voltage source be 1. It moreover demonstrated that the change coefficients of Park transformer changing four-stage AC framework to dqg0 framework function admirably. SEPT can give DC capacity to utilities with great quality, since it has a DC trade. When there is an issue happens, the exchanging gadgets can slice off circuit very soon to forestall the issue's spreading.

#### REFERENCES:

- [1] C. Chen, C. Mao, D. Wang, and J. Lu, “The research on special electronic power transformer,” *Istanbul Univ. - J. Electr. Electron. Eng.*, 2009.
- [2] G. Benysek, M. P. Kazmierkowski, J. Popczyk, and R. Strzelecki, “Power electronic systems as a crucial part of Smart Grid infrastructure - A survey,” *Bulletin of the Polish Academy of Sciences: Technical Sciences*. 2011.
- [3] F. Briz, M. Lopez, A. Rodriguez, and M. Arias, “Modular power electronic transformers: Modular multilevel converter versus cascaded h-bridge solutions,” *IEEE Ind. Electron. Mag.*, 2016.
- [4] M. Kang, P. N. Enjeti, and I. J. Pitel, “Analysis and design of electronic transformers for electric power distribution system,” *IEEE Trans. Power Electron.*, 1999.
- [5] D. Wang *et al.*, “A 10-kV/400-V 500-kVA Electronic Power Transformer,” *IEEE Trans. Ind. Electron.*, 2016.
- [6] Z. Zhao, J. Yang, Q. Zhu, C. Wang, and F. Jian, “A direct AC-AC converter for electronic power transformer based on energy injection control,” in *Proceedings of 2016 2nd International Conference on Control Science and Systems Engineering, ICCSSE 2016*, 2016.
- [7] D. Ronanki, S. A. Singh, and S. S. Williamson, “Comprehensive Topological Overview of Rolling Stock Architectures and Recent Trends in Electric Railway Traction Systems,” *IEEE Trans. Transp. Electrif.*, 2017.
- [8] C. T. Liang, K. L. Chen, Y. P. Tsai, and N. Chen, “New electronic current transformer with a self-contained power supply,” *IEEE Trans. Power Deliv.*, 2015.

- [9] K. Woronowicz, A. Safae, and T. R. Dickson, "Single-Phase Zero Reactive Power Wireless Power Transfer Topologies Based on Boucherot Bridge Circuit Concept," *Can. J. Electr. Comput. Eng.*, 2015.
- [10] K. George, "Solid-State Transformers for Interfacing Solar Panels to the Power Grid : An Optimum Design Methodology of a High Frequency Transformer for dc-dc Converter Applications," *Inq. Univ. Arkansas Undergrad. Res. J.*, 2016.