

Child Rescue System from Open Bore-Well

S.Bhaskar Rao¹, M. Amarnath Reddy²

^{1,2}Assistant Professor, Department of ECE, CVRT Engineering college, Tadipatri

ABSTRACT

In India for past few days people are facing a distressed cruel situation like child have fell in the bore well and struck in the hole which is uncovered and getting trapped. Rescue of trapped child from bore well is very risky and difficult process when compared to the other accidents. The currently available systems to save the child are less effective and costly too. It takes more than a day to save the child. Here, the child who is stuck inside the hole is to be saved by the clipper which pick and place the child with the help of remote controller. The clipper is left inside manually by the rope tied up at its hands. In this alternative scenario there will not be any requirements of digging hole parallel to the bore well. It also consists of camera which is affixed to the clipper which is used for monitoring the child. By this camera we get the visuals of the child and their condition.

1. INTRODUCTION

In current framework, growing water scarcity is the major problem which people come across in day-to-day life. Small children without spotting the hole dug for the bore-well slip in and get trapped. These accidents are mainly happened due to inattention or playful activities of the child. The occurrence of latest technique provides pragmatic opportunity for new robot power and awareness of new methods of control theory. The present robot control system can be used for different enlightened robotic applications. Robots have been very successful at manipulation in simulation and controlled environments. If the child fall into open bore-wells and rescue operations was almost end with failure. We are developing a robot machine that can take out the trapped body in a systematic way. It will be a light weight machine that will be setup easily into bore-well and hold the trapped body systematically. In this technology, there will be no requirement of digging any hole parallel to the borewell. With this machine, we can save the child within less time compare to convectional method. and this system named as “Child Rescue System in Open Bore-Well”. Very few of the victims have been saved in such accidents. In some of these cases the dead body of the subject could not be collected easily. Even if rescued late, most victims were reportedly injured. To overcome such problems of these rescue operations, we have an alternative (feasible) proposal. We are developing a robot machine that can take out the trapped body in systematic way. This machine assembly will be supported by a cable wire and this will be controlled and supported by a gear assembly. In this alternative scenario, there will be no requirement of digging any whole parallel to the bore-well. The remotely controlled robot will go down the bore well and perform the action. A lot of other hassles will also be avoided by this alternative technique. The rescue of these trapped children in an uncovered bore-well is not only difficult but also risky. A small delay in the rescue operation can lost the life of the child. To lift the child out the narrow confines of the bore wells is also not very easy. Robot for bore well rescue system, offers a solution to these kinds of situations. It is fast, economical and safe.

- The main objective of this project is to design and construct a portable system which is cost effective, quick in action and accurate.

- The Borewell Rescue System is capable of moving inside the well and performs operations according to the user commands.
- Once the system has reached proximity of child, it is stopped immediately and is given the commands by the controlling device to perform the closing of the systemic arms
- This system consists of gas sensor, which is capable of sensing any gas near the child.
- Manually monitoring the child with the help of camera and controlling unit of system.

2. LITERATURE SURVEY

For finalizing objective of our project work we have reviewed following research papers majorly being related with the technology which we have used in our project work “Child Rescue System from Open Borewells”, apart from books and websites. 1. Sumit Pandey. Is explained is based on rescuing infants who have fallen into the borewell. An abundance child death reports have been reported so far. Due to scantiness of water level, bore well are dig to more depth. The basis of this project is to rescue the infant. The rescue is done by digging a parallel pit, which takes more than a day and even have not found a genuine result. The high point of this project is that the child will be rescued before it reaches high depth, which is based on communications using Infra-Red Signals. When the IR signal, placed two inches diametrically under the ground surface of bore-well, breaks due to any obstructing object, a buzzer starts sounding as an alert in mobile phone. After a stake that is kept a few feet lower in the bore-well, closes the bore in order to prevent the infants falling deeper into the well. These accidents are substantially found in agricultural borewell. 2. Prof. Chandra Kumar H S, explain several accidents of children falling into an abandoned bore-well which is left uncovered and get trapped. Abandoned bore wells seems to be death pits for children. These bore-wells in turn have started to take many innocent lives. In such cases normal operations of child rescue from bore-wells is very complicated process with big machines and large man power. The aim of this paper is to rescue children falling in to bore-wells, this implies a new design which has a sensor kept at top of borewell hole which helps to sense the child if he falls inside. If the system senses the child the automatic horizontal closure kept at around 3ft dept closes and prevents the children from falling beneath. It has the facility to monitor the trapped child, and provide a supporting platform to lift up the child driven by motors. The motor placed at the top turns a gear mechanism which, in turn, pushes 3 blocks arranged at 120 degrees from each other towards the side of the bore well. The whole system is firmly to the bore-well wall. 3. M R Chaitra explain generally based on the child rescue in the bore well. Nowadays child falls into an abandoned bore well, which is left uncovered and get trapped. Normal operation to rescue the child is to pit a dig nearer to the bore well. That logic is difficult and also risky to rescue the trapped child. It takes extra time to recover the child from the bore well. Here we are proposing a robotic system which will attach a harness to the child using pneumatic arms for picking up. A teleconferencing system will also be attached to the robot for communicating with the child. The mechanical system moves inside the uncontrolled bore well. Accordance with the user command given to the Arduino, the mechanical setup is controlled. The hardware is attached to the PC, to stimulate the DC motor. This kind of system can release trapped baby from the bore well securely within lesser time. In order to implement this, we are using IP camera, Bluetooth, Microcontroller 8051(newton). 4. A Sumalatha proposed scenario there have been several incidents reported on abandoned borewells which are turning in to death wells. Many innocent children are being trapped into these borewells and losing their lives. The actual purpose of borewells is to

save lives, but these borewells in turn have started taking many innocent lives. In several cases the rescue operations are done by big machines and lot of man power involvement. Usually, these rescue operations are very lengthy, complicated and very time taking processes. The project presents a simple and effective method to rescue the child from the borewell. The traditional way to rescue the child is to dig a parallel pit t adjacent to the bore well. This method is difficult, lengthy and also risky to rescue the trapped child. In the proposed method mechanical system moves inside the borewell channel and moves its gripper arm in accordance with the user commands given. The hardware is interfaced to the PC and Arduino setup is used to control the mechanical set up. 5.Jayasudha.M, Saravanan, proposed water scarcity is the principal inconvenience. To overcome these issues, people initiated to burrow bore well. In our nation, the vast majority of the people are agrarian and they depend on the water for irrigation system. Children involuntarily fall into the bore well which yielded water and left revealed. The process of saving the trapped child into bore well is relatively challenging. At present, the rescuing task is accomplished by the method for burrowing a parallel pit close to the bore well with the same depth of the child and makes a passage that interfaces with the two wells. To overcome this concern, a well-planned robot is designed in a unique way, that it saves the stuck child and also it observes the child carefully by using web cam within a short time span. It consists of two modules which are rescuing system and protection system.

3. PROPOSED SYSTEM CONFIGURATION

The bore wells, which successfully hit the water does not pose any threat because those are completely sealed with casing after installing the motors. Bore-wells which are not successfully hit the water at maximum depths, they are left uncovered and abounded. Such bore wells are called dry or dead borewell, these uncapped bore-wells become threat to the children. There are many incidents filed against bore-well death of children are rising day by day. Up to now the methods used to save the child, fallen in the bore-well is manual rescue method. In which a big hole is dug beside the bore well up to the depth where the child is stuck. During this process a huge number of human resources (military, Paramedical, etc.), machinery (JCBs, Tractors, etc.) is used. A small delay in these resource accumulations may reduce chances of saving child alive. If the area beside the bore hole contains rocks below certain depth, this situation becomes very worse if the size of the rock is very big in such cases the whole process is to here initiated again from new place. In such cases the chances of saving child alive is very low. Whatever may be the case the success ratio depends on lots of factors like availability of machinery, time taken for transportation of machinery to the situation, availability of human resources and mainly the response time of various government organizations. In India according to the NCRB report of 2011 there are 5 average deaths per day due to the abandon bore wells.

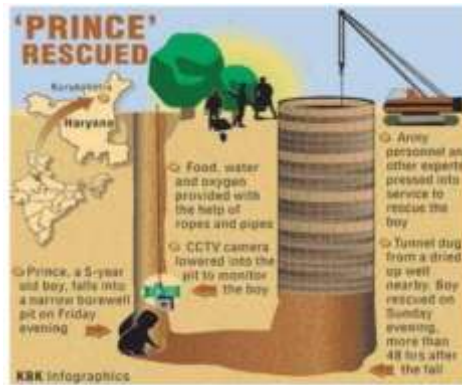

Fig 1 Existing System

Here in this project, the child who is stuck inside the hole is to be saved by the clipper which pick and place the child with the help of remote controller. The clipper is left inside manually by the rope tied up at its hands. In this alternative scenario there will not be any requirements of digging hole parallel to the bore well. It also consists of camera which is affixed to the clipper which is used for monitoring the child. By this camera we get the visuals of the child and their condition.

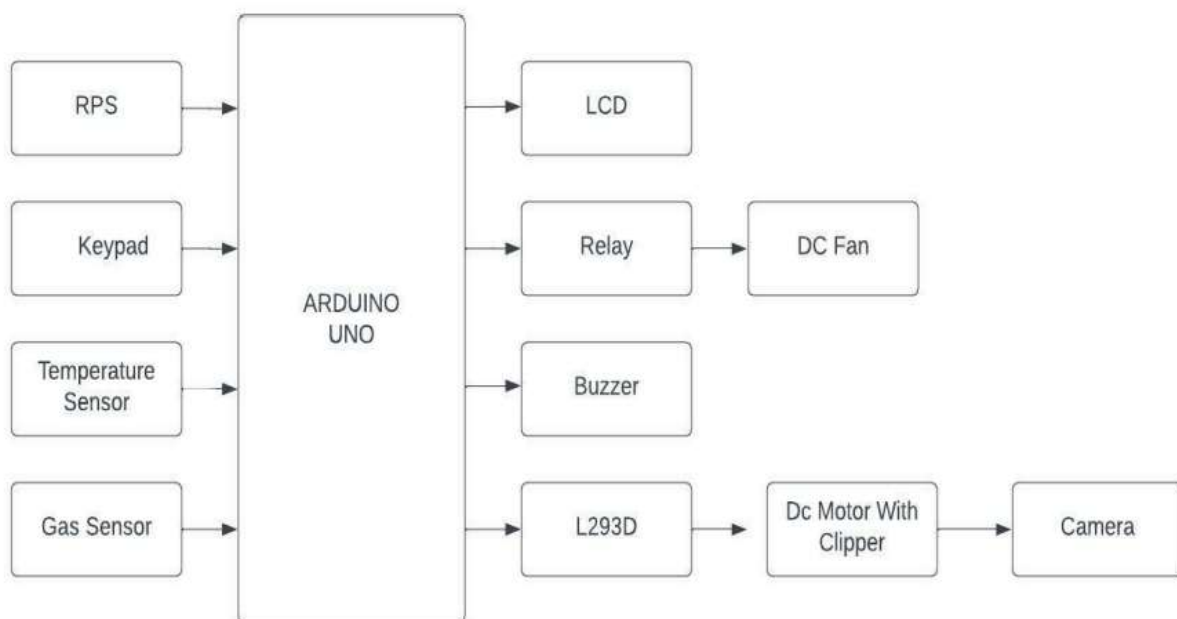

Fig 2 Block diagram

In this block diagram Even though there are lot of methods existing to save the child from open borewell, still there is a need of simpler and more sophisticated rescue equipment. Here we are using the methodology called Arduino based child rescue system from borewell. In this system there is not necessary to dig the parallel pit adjacent to the bore well up to the depth of the child where they stuck. Hence this method does not depend on more human resources, and machinery. This method consists of highly advanced microcontroller, well developed accurate hand gripping mechanism Arduino UNO is a controller board based on the ATMEGA328P. it has 14 digital input and output pins (of which 6 can be used as pwm outputs). 6 analog inputs and 16mhz ceramic resonator. A USB connector. a power jack and

icsp/0 header and reset buttons Arduino UNO consist of some input and output devices. The left side of the diagram consist of input devices in which rps, keyboard, temperature sensor and smoke detector. Rps is the Regulated power supply which is used to supply the input power to drive the circuit. Temperature sensor is used to find the voltage diode terminals of the voltage increases then the temperature also rises. Next comes to smoke detector (MQ4) here smoke detector used to issue a signal fire alarm or buzzer whenever it detects smoke also can be displayed on LCD, which ionizes the air and causes current to flow between the plates. When smoke enters the chamber, it disrupts the flow of ions, thus reducing flow of current and activates buzzer.

Advantages

- It is also be used in various applications for picking different objects, where human involvement is not much preferred.
- Efficient and low-cost design
- By this project we can save the child in less time
- Video Surveillance
- Less Man Power Required
- High reliability – it is a multiple times usable device
- Easily Operable – using a keypad joystick make the device easy to use

LIMITATIONS

- We have to check belt mechanism.
- The sensors which are used in this project are sensitive



Fig 3 Final position of hardware kit



Fig 4 Output of Stage I Result

In stage 1 in this project, it contains of gases sensor which is used to find any harmful gases near the child and it equipped by temperature sensor which is used to find temperature near the child. Those gases and temperature are displayed on the display. By the stage 1 we are ensuring that the child is in safe place or not.



Fig 5 Output of Stage Ii Result



Fig 6 Object Pick Up with Help of Gripper

In stage 2 clipper is attached to the kit which performs the activity of pick and place which is used to pick the child from hole and it contains of camera, by this we get the visuals of the child and their condition.

4. CONCLUSION

“Smart and Safe child rescue system” is mainly designed to save many lives of children who fall inside the bore well. In the past 10 years, lots of lives had been lost by falling in to the bore well because digging a pit beside the bore well is too long and time-consuming process. By using proper motors, arms and advanced technology this project is implemented successfully. This can be concluded that the proposed system can retain the lives of many children who fall into the bore well in future.

Future Scope

In future this project will be used in several applications by adding additional components to this project. 1. This proposed system can send these robots to dangerous zones by connecting smoke sensor to the robot we can get the information related concentration of smoke or gases in respective fields and sensor will detect the poisonous gas and it gives information to the Microcontroller and microcontroller gives the information to the transceiver from that we can get the data on the PC side. 2. The future upgrade of our task is to incorporate Gas sensor which is utilized to check any lethal gas present inside the bore well. Although this, an oxygen test can be associated which is utilized to supply oxygen to the kid. 3. Then the potentiometer is get replaced by hand gesture mechanism to increase the rescuing time from the bore well.

5. REFERENCES

1. B. Bharathi, B. Suchitra Samuel “Design and Construction of Rescue Robot and Pipeline Inspection Using Zigbee” Ieee, September 2016
2. Sridhar Palani swamy “Life Saving Machine” The First International Conference on Interdisciplinary Research and Development, 31 May-1 June 2011, Thailand.
3. Manish Raj, Chakraborty and G.C. Nandi “Rescue robotics in Bore Well Environment” Cornell University Library [V1] Mon, 9 Jun 2014
4. Venmathi, V., E. Poornima, And S. Sumathi. "Borewell Rescue Robot." ieee (2015).
5. Sridhar, K. P., And C. R. Hema. "Design And Analysis of a Bore Well Gripper System for Rescue." Arpn Journal of Engineering and Applied Sciences 2016
6. Nitin, G., Et Al. "Design and Simulation of Bore Well Rescue Robot-Advanced." Arpn Journal of Engineering and Applied Sciences 9.5 (2014)
7. Kurukuti, Nish Mohith, Et Al. "A Novel Design of Robotic System for Rescue in Bore Well Accidents." 2016 (Raha). Ieee
8. Shah Vrunda, R., Chirag S. Dalal, And Rajeev Dubey. "Automate Machine for Rescue Operation for Child." ieee (2015).
9. Rajesh, Singuru, Gamini Suresh, And R. Chandra Mohan. "Design And Development of Multi-Purpose Prosthetic Bore Well System-An Invincible Arm." Materials Today: Proceedings 4.8 (2017)
10. Retnakumar, Joselin G., Et Al. "Automated Bore Well Rescue Robot." Far East Journal of Electronics and Communications 16.4 (2016)