

SVM-based analysis of the DC-DC converter used in EVs

R B R Prakash,

Department of Electrical and Electronics Engineering, Koneru Lakshmaiah Education
Foundation, Vaddeswaram, AP, India

T Vijay Muni,

Department of Electrical and Electronics Engineering, Koneru Lakshmaiah Education
Foundation, Vaddeswaram, AP, India

P Srinivasa Varma

Department of Electrical and Electronics Engineering, Koneru Lakshmaiah Education
Foundation, Vaddeswaram, AP, India

Abstract:

This research proposes switching operational modes using a bidirectional DC/DC converter, popular in battery-powered EVs. The suggested design shifts the converter from boost to buck mode when DC-link voltage is too high. This strategy could reduce the EV energy storage system's carbon impact and increase efficiency. A buck-boost DC/DC converter raises the DC-link voltage while driving and charges the battery while braking. PI control stabilizes the DC-link voltage during boost mode driving. Buck mode PI battery voltage control reduces voltage ripples. Both forms of operation use current control to distribute battery current evenly amongst converter modules. The proposed technique is tested utilizing an EV propulsion system in a simulation.

1. Introduction:

The electric vehicle (EV) market has grown rapidly due to air pollution, global warming, and rising fossil fuel consumption. Power electronic converters and drive systems make up EVs, and various research efforts aim to improve their density and efficiency. PEVs, HEVs, and FCEVs will soon be available. Battery-powered electric motors will be linked to voltage source inverters in all these vehicles. Electric vehicles (EVs) are a potential alternative to gas-engine cars due to the desire to reduce fossil fuel use and pollution. Due to limited EV battery capacity, widespread charging stations are needed for EV development and utilization. When

many charging stations are directly connected to the grid, peak load, voltage drops, and power gaps might occur. Some scientists have investigated integrating photovoltaic (PV) generating with EV charging infrastructure, however it currently provides a tiny quantity of electricity. Given the rising need for high-speed charging throughout the day, rapid PV production optimization during peak hours is crucial. In response to intermittent solar energy, battery energy storage (BES) can adjust DC bus or load voltage, balance power gap, and smooth PV power.

2. Electric Vehicles

A transmission system connects a battery pack to an electric motor to power a typical electric vehicle (EV). A electrical outlet powers a battery charger to charge batteries. When regenerative braking slows the car, the motor acts as a generator, delivering energy to the batteries. Electric vehicles (EVs) are advantageous due to their simple design and few parts. Electric vehicles (EVs) have a limited driving range due to battery capacity. From 15 minutes to 8 hours, EV batteries can be recharged. This fluctuation depends on the battery type, charging method, and distance driven before recharging.

3. Proposed Circuit Configuration:

Digitally controlled DC-to-DC converters are used to charge and replace EV batteries. It switches voltage at circuit points using semiconductor power switching devices. In non-linear systems, semiconductor device switching delays. Different control strategies can stabilize the system's output voltage and improve performance [1]. Since Proportional-Integral-Derivative (PID) control is simple to develop and implement, DC-DC converters commonly use it. Traditional PID controllers use mathematical models with predefined constants. PID controllers use predefined parameters for stability. PID controllers are widely used in industrial applications to improve system performance. Fig. 1 shows the DC-DC converter in use with the most common control layout. A DC-DC converter, signal conditioning device, and digital control and gate driver are included.

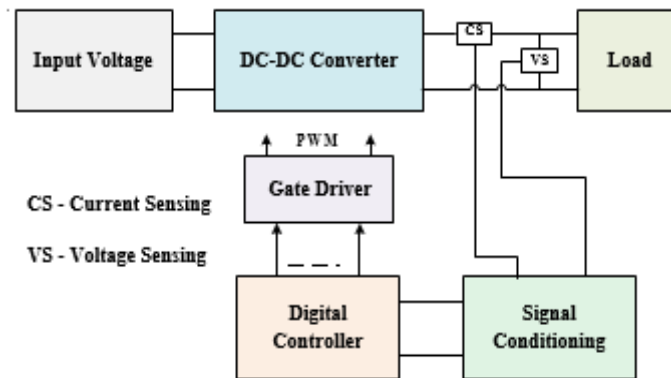

Figure 1. Conventional control approach of DC-DC converter

Simple design and control make the multiphase interleaved converter a popular study. It's used for non-isolation, step-down conversion ratios, big output currents with low ripple, etc. Multi-phase output inductor selection flexibility is crucial for tiny form factor applications. Multiphase operation allows various phase combinations and phase shedding for optimal converter performance.

4. Operation Modes of the Proposed Converter:

The suggested converter is not only multidirectional, but also uses multiple inputs and outputs as described in [10]. The suggested structure improves the converter's efficiency by allowing for many charging modes, such as the battery discharge mode, battery charging via the inputs, and battery charge mode in the braking mode. In the sections that follow, each of the aforementioned modes is further developed and mathematically evaluated separately. The utilisation of the multi-stage m-level multiplier circuit causes a minimal voltage stress on the S0 of the suggested converter.

5. Power supply mode with battery discharge:

5.1 The converter powers the load with battery and other inputs in this configuration. The mathematical analysis has two inputs (the battery and one primary source) and two outputs (the two outcomes). The brake switch (S3 and Sb) is always off, the transfer switch (ST) is always on, and all other switches are on. This setting allows output voltage (VO) adjustment with switches S0, S1, and S2. The converter's major waveforms in this mode are presented in

Fig. 2 and its operational condition in Fig. 3. See Fig. 4 for the converter's switching orders in this mode:

5.2 Time interval $0 < t < DT$:

In this configuration, the battery and the other sources are both used to power the load connected to the converter. As a result, it is possible to use all linked resources at once. There are two inputs and two outputs in the mathematical analysis. In this setup, all switches except for S_3 and S_b are active. In this mode, the output voltage (V_O) is managed by a series of switches whose on/off sequence is determined by the values of S_0 , S_1 , and S_2 .

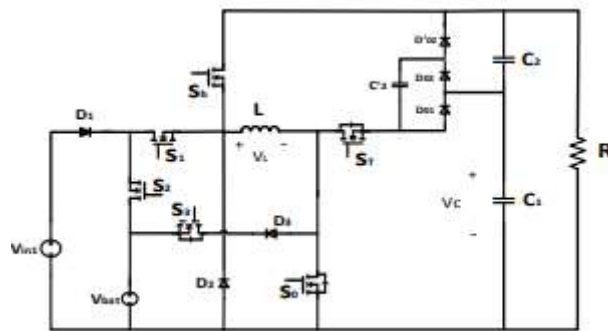

Figure 2: Proposed converter with two-input and two-output

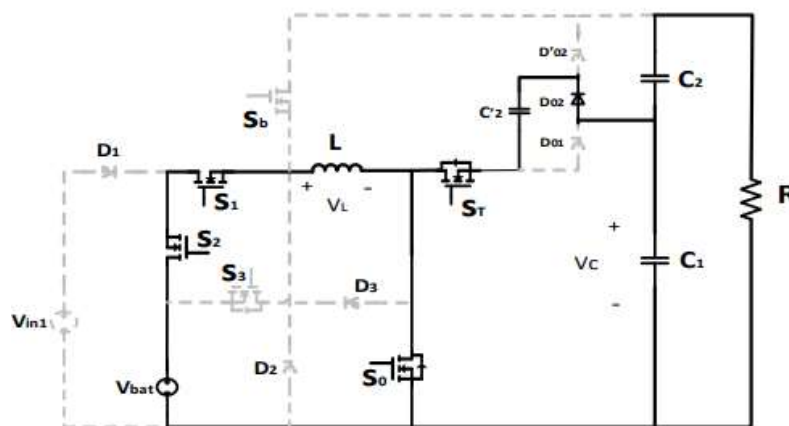

Figure 3: equivalent circuits of the converter in mode A at time interval $0 < t < DT$

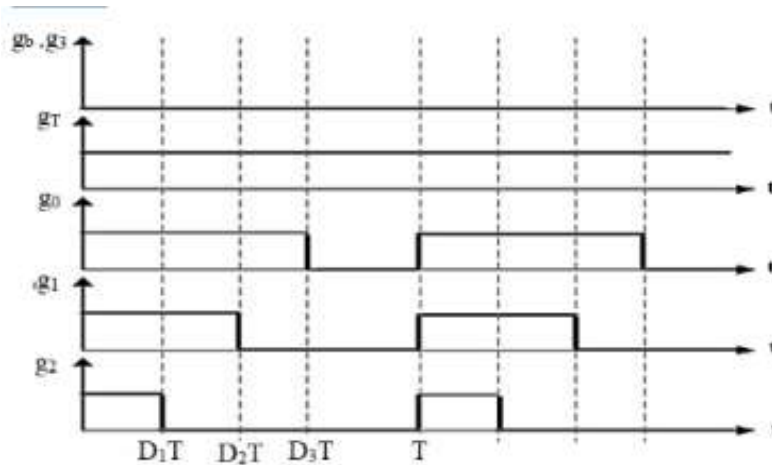

Figure 4: switching states of power supply mode with battery discharge

5.2 Time interval $D1T < t < D2T$:

The $S0$ is active, while the $S1$ is inactive, and the rest of the circuit looks like Fig. 4. The inductor is charged by the primary power source (fuel cell, for instance). The inductor's voltage is the same as the mains voltage, and the inductor current rises in a straight line with a shallower slope ($V_{bat} > V_{in1}$). Its inductor current looks like this while operating in this mode:

5.3 Time interval $D2T < t < D3T$:

Here, we have $S0$ turned on and $S2$ and $S1$ turned off. The inductor acts as a current path, activating diode $D2$. Using KVL with a circuit consisting of a diode, an inductor, and $S0$:

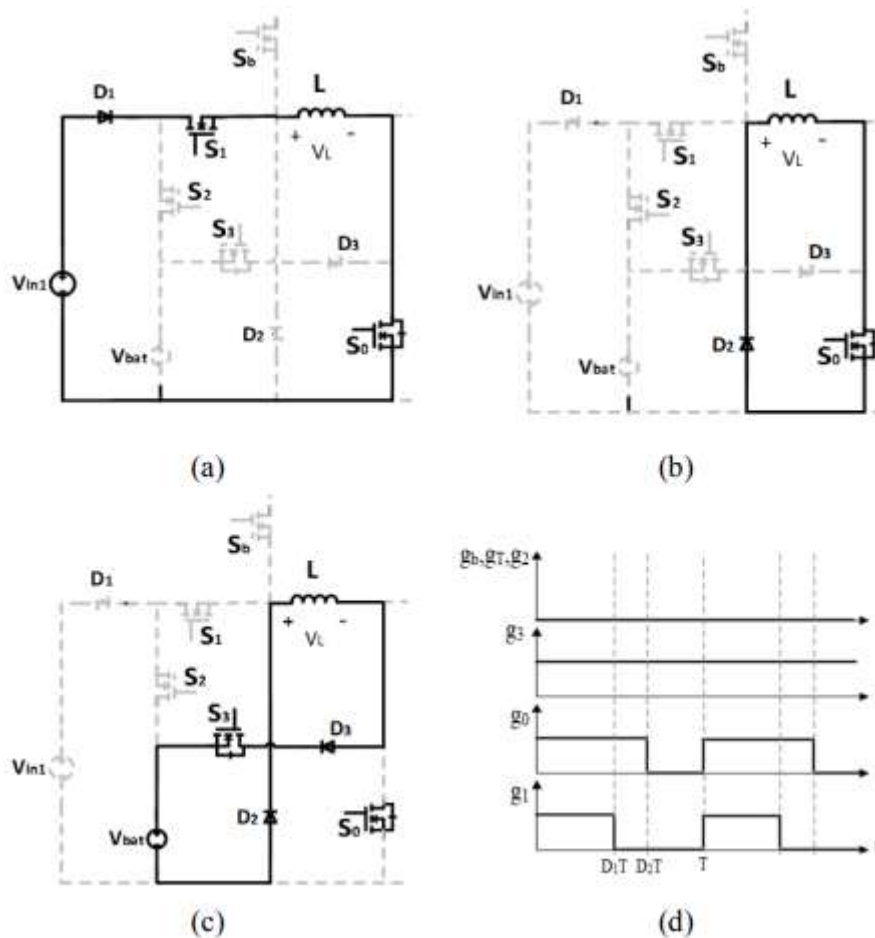

Figure 5: Switching state in battery charge mode via input sources (a) switching state1 (b) switching state 2 (c) switching state 3 (d) switching sequence in this mode.

5.4 Battery charge mode via input sources:

The battery is being charged by the input sources while in this mode. This state is reached by the battery whenever there is no load being carried and the battery must be recharged. As shown in Fig. 2.10, all but switch S1 are always ON, while switches S2, ST, and Sb are always OFF. Three different converter switching states are studied in this mode.

5.5 Time interval $0 < t < D_1T$:

Both S0 and S1 switches are active in this switching state. As a result, there is no current flowing through the D3 and S3 diodes since they are reverse biased. Charge is applied to inductor L from the input source (V_{in1}), and the current flows steadily upwards.

5.6 Battery Charging Mode in Braking Operation:

The motor vehicle may function as a generator and store energy in the battery when braking or travelling downhill. Transducer performance is optimised in this mode of operation. To achieve this result, a switch is installed in the reverse circuit to convert the high voltage to the lower voltage of the battery, so conserving power. All other switches are on and functioning normally, whereas S0, S1, and ST are constantly turned off. In this mode, Sb regulates the battery's output voltage (Vbat. The converter is a standard buck converter while in the braking mode. There are a few of different ways that the switch may be thrown:

5.7 Time interval $0 < t < D1T$:

The Sb mode is activated here. What this means is that the inductor's voltage is defined as the difference between Vo and Vbat. So, here is a linear progression of the inductor current:

$$i_{L3} = I_{LV3} + \frac{1}{L} \int_0^t V_L dt$$

6. Space Vector Modulation Technique:

Instead of using a standard pulse width modulation method, this system takes use of the two phase vector components—d and q—to provide gate triggering signals. Figure 6 depicts the 8 space vector switching pattern locations of the inverter, each of which represents a different space vector representation of the neighbouring vectors V1 and V2.

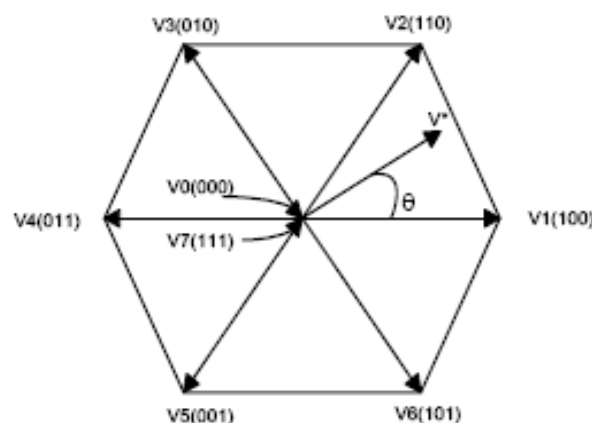

Figure 6: Space Vector Modulation Technique

By using the Space Vector Modulation Technique, one of the most widely used pulse width modulation techniques for three-phase voltage source inverters, we can reduce harmonic distortion in the applied ac motors' voltage and current. In this research, we use the space vector modulation method to produce reference vectors by varying the switching time sequence of space vectors over six distinct sectors, as seen in Fig. 6. Figure 6 shows that six switching sectors are used for inversion, with two sectors behaving similarly to null vectors. The following methods may be used to carry out space vector modulation:

To convert three-phase values to two-phase ones.

2) Calculate T1, T2, and T0.

The following phrase creates the voltage reference signals, the V0–V7 switching time sequences, and the switching times themselves.

$$V^* T_z = V_1 * T_1 + V_2 * T_2 + V_0 * (T_0/2) + V_7 * (T_0/2)$$

7. Simulation Diagrams And Results

The suggested converter is shown via simulation, and its performance across all three modes of operation is validated. The MATLAB/Simulink environment is used for the simulations, and the settings for those simulations are shown.

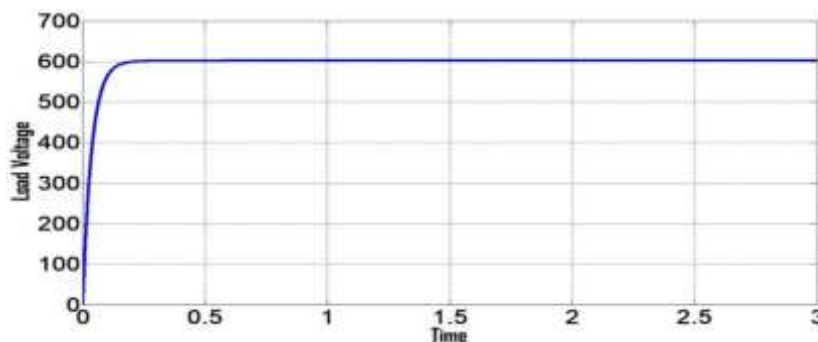

Figure 7: Load voltage of converter (V0) during battery discharge mode using PWM

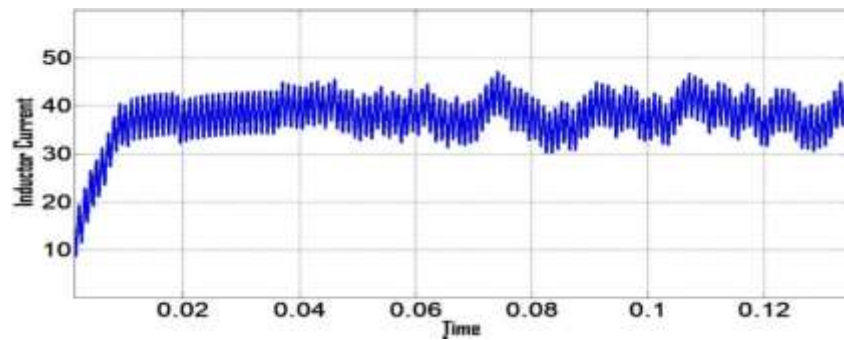

Figure 8: Inductor current (i_l) during battery discharge mode using PWM

7.1 Simulation Results during battery charge in braking mode using PWM:

The battery is charged by the regenerative energy, and the load voltage is used as an input. When the brakes are applied, just switch S_b is on, and charging power for the battery is delivered via that. The converter functions as a buck converter, with the load voltage serving as the charging power source.

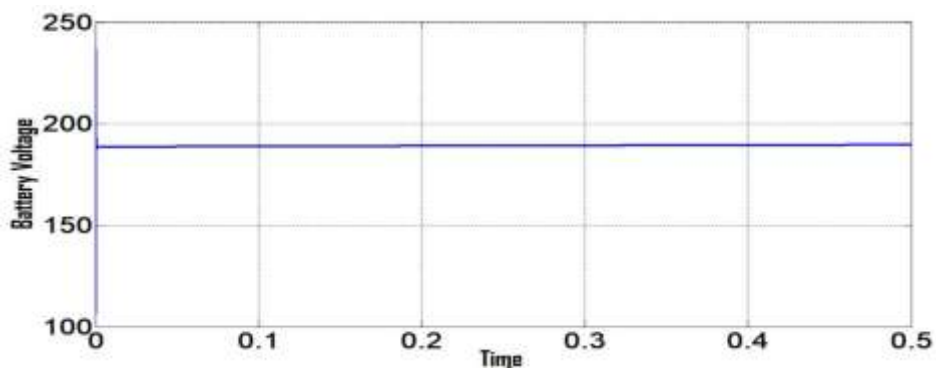

Figure 9: Voltage of battery (V_{bat}) during battery charge in braking mode using PWM

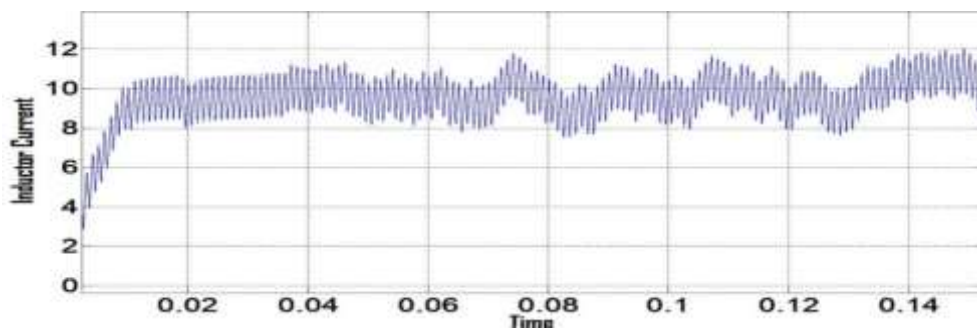

Figure 10: Inductor current (i_l) during battery charge in braking mode using PWM

7.2 Simulation results during battery discharge using SVM:

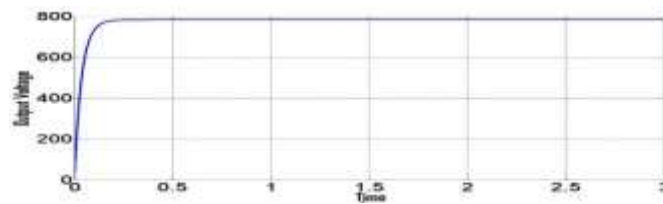

Figure 11: Load voltage of converter (V0) during battery discharge mode using SVM

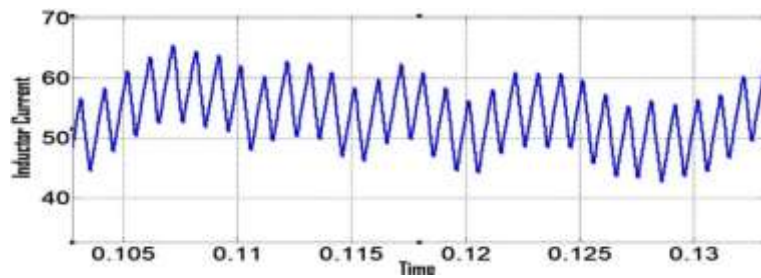

Figure 12: Inductor Current of converter during battery discharge mode using SVM

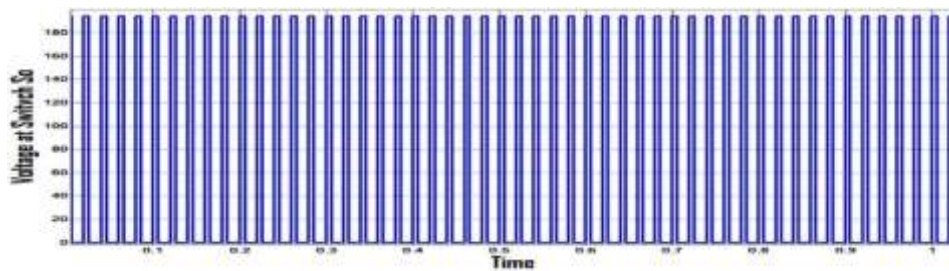

Figure 13: Voltage across switch (So) during battery discharge mode using SVM

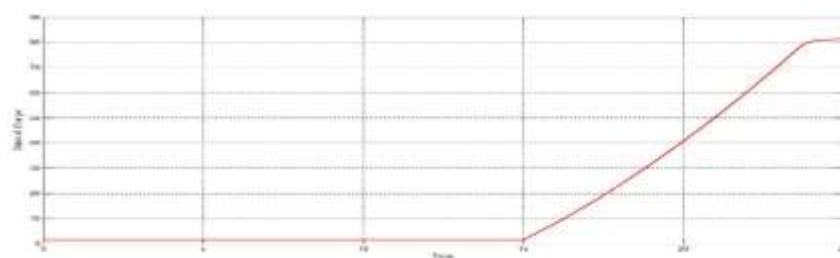

Figure 14: EV Battery Charging Conditions using PWM Controller



Figure 15: EV Battery Charging Conditions using SVM Controller

8. Conclusion

This research proposes a Space vector modulated bidirectional non-isolated converter design to improve dc-dc converter efficiency. High voltage gain without high duty cycle and high-frequency switching and flexibility to transfer energy across resources with different voltage and current profiles are the converter's main advantages. In addition, the output voltage multiplier inverter considerably minimizes primary switch voltage stress. The converter proposed may boost and buck. This project displayed converter modes. To ensure the design worked, a two-input, two-output converter's simulation results were validated. A space-vector-modulation-based converter's switching action is less demanding on the voltage supply, allowing for more flexibility in switching sequences.

References

- [1] M. Ehsani, Y. Gao, and A. Emadi, *Modern Electric, Hybrid Electric and Fuel Cell Vehicle Fundamentals, Theory and Design*, 2nd ed., New York, Press, 2019.
- [2] S. Mohammad salehian, F. Sedaghati, R. Eskandari and E. Shokati Asl, "A Modified Double Input Z-source DC_DC converter for Standalone PV/Battery System Application," in Proc. Tehran, Iran, 2016.
- [3] T. sharifi, A. Haji Biglo, M. Mirsalim, S. Farzamkia and J. S. Moghani, "An asymmetrical cascaded single-phase quasi Z-source multi-level inverter with reduced number of switches and lower THD," Tehran, Iran, 2017.
- [4] F. Sedaghati, S. Mohammadsalehian, H. Shayeghi, and E. S. Asl, "A configuration for double input Z-source DC-DC converters," Tehran, Iran, 2018.
- [5] A. Haji Biglo, S. Farzamkia, S. Farhangi and H. ImanEini, "Utilization of Soft-Switched Boost Converter for MPPT Application in Photovoltaic Single-Phase Grid-Connected Inverter," in Proc., New York, 2011.
- [6] S. H. Hosseini, R. Ghazi, S. Farzamkia and M. Bahari, "A Novel High Gain Extendable DC-DC Bidirectional Boost-Buck Converter," in Proc., Iran, 2015.
- [7] F. Sedaghati, S. Mohammad salehian, H. Shayeghi, and E. S. Asl, "A configuration of double input Z-source DC-DC converter for standalone PV/battery system application," *Journal of Energy Management and Technology*, 2(3), pp.60-69.

- [8] S. Soylu, *Electric Vehicles – Modelling and Simulations*. Rijeka, Croatia: Intech Europe, 2011.
- [9] A. Ansari, P. Cheng, and H.-J. Kim, "A 3 kW Bidirectional DC-DC Converter for Electric Vehicles", *Journal of Electrical Engineering Technology*, vol. 11, no. 4, pp. 860-868, 2016.
- [10] A. K. Rathore and U. R. Prasanna, "Analysis, Design, and Experimental Results of Novel Snubberless Bidirectional Naturally Clamped Converter for Fuel Cell Vehicles", *IEEE Trans. Ind. Electron.*, vol. 60, no. 10, pp. 4482–4491, 2013
- [11] T. Mishima, E. Hiraki, "A dual voltage power system by battery/supercapacitors hybrid configuration", in *Proc. Power Electronic Specialists Conf.*, pp.1845-1852, June 2005.
- [12] S. Rezayi, H. Iman-Eini, M. Hamzeh, S. Bacha, S. Farzamkia, "Dual output DC/DC boost converter for bipolar DC microgrids", *IET Renewable Power Generation*, vol.13, pp.1402-1410, 2019.
- [13] E. Sanchis-Kilders et al., "Bidirectional high-power high-efficiency non-isolated step-up dc-dc converter", *PESC'26*, in *Power Electronics Specialists Conference*, 2006. 37th IEEE, pp. 1-7.
- [14] B. V. Kumar, R. K. Singh, and R. Mahanty, "A modified non-isolated bidirectional DC-DC converter for EV/HEV's traction drive systems," in *2016 IEEE International Conference on Power Electronics, Drives and Energy Systems (PEDES)*, 2016, pp. 1-6.