

# MICROSPONGES: AN INNOVATIVE STRATEGY FOR DRUG DELIVERY SYSTEM

Neelam Jain\*, Neeraj Jain<sup>1</sup>, Shubham Sharma<sup>2</sup>, Alka<sup>4</sup>, Lakshmi Mishra<sup>5</sup>

\*Faculty of Pharmacy, Oriental University, Indore-453555, M.P., India.

<sup>1</sup>Teerthankar Mahaveer College of Pharmacy, TMU, Moradabad- 244001, U.P., India.

<sup>2</sup>Signa College of Pharmacy, Kanpur-209304, U.P., India.

<sup>3</sup>Amity Institute of Pharmacy, Amity University, Lucknow campus, Uttar Pradesh, India.

<sup>5</sup>Faculty of Pharmaceutical sciences Rama University, Mandhana, Kanpur-209217, U.P., India.

**\*Corresponding author name:** Neelam Jain

**\*Corresponding author address:** Faculty of Pharmacy, Oriental University, Indore-453555, M.P., India.

**Email id:** neelamnj02@gmail.com

**Contact no:** +91-8982753610

## ABSTRACT:

Conventional topical formulations are intended to work on the surface of the skin. Normally, upon application such formulations release their active ingredients and producing a highly concentrated layer of active ingredient that is quickly absorbed. Therefore, need exists for a system to increase the amount of time that an active ingredient is present either on skin surface as well as within the epidermis, at the same time, minimizing its transdermal penetration in the body. Recently, microsp sponge delivery system (MDS) has been successively addressed for the controlled release of drugs onto the epidermis with assurance that the drug remains chiefly localized and does not enter the systemic circulation in major amounts. MDS is a unique technology for the controlled release of topical agents, also use for oral as well as biopharmaceuticals (peptides, proteins and DNA-based therapeutics) drug delivery. It consists of microporous beads having a range of 10-25 microns in diameter that possess a versatility to entrap wide range of active agents. This review article covers methods of preparation, release mechanism, characterization and applications of microsp sponge delivery system with patent information and marketed formulations.

**Keywords:** Microsp sponge, Controlled release, Topical delivery, Biopharmaceutical delivery

## INTRODUCTION:

Drug delivery systems that can specifically control the release rates and target drugs to a specific site of body had a vast impact on the health care system. Various consistent and predictable (conventional) systems were developed for systemic drugs delivered through skin under the title of transdermal delivery system (TDS). It has enhanced the safety and efficacy of several drugs

that may be administered through skin however, TDS is unrealistic for the delivery of drugs whose ultimate aim is skin itself<sup>1</sup>. There is no efficient vehicles have been developed for controlled as well as localized delivery of drugs into the stratum corneum and not beyond the epidermis<sup>2</sup>. Furthermore, the significance of topical drugs suffer from various problems i.e. ointments, which are frequently unappealing, greasiness, stickiness etc which in turn leads to lack of patient compliance. These vehicles necessitate high concentrations of active agents for successful therapy because of their less efficiency of delivery system resulting into irritation and allergic reactions in significant users. Additional potential limitations of topical formulations are unpleasant odor, uncontrolled evaporation of active ingredient and incompatibility of drugs with the vehicles. Conventional topical formulations are intended to work on the superficial layers of the skin. Normally, upon application such products release their active ingredients and producing a highly concentrated layer of active ingredient that is quickly absorbed. Therefore, need exists for a system to increase the amount of time that an active ingredient is present either on skin surface as well as within the epidermis, at the same time, minimizing its transdermal penetration in the body. Recently, microspunge delivery system has been successively addressed for the controlled release of drugs onto the epidermis with assurance that the drug remains chiefly localized and does not enter the systemic circulation in major amounts and resulted in a new creation of highly efficacious and well tolerated novel products. Microsponges are porous microspheres that are capable to absorb skin secretions consequently, reducing oiliness and shine from the skin. Microspunge particles are extremely small, inert, indestructible spheres that do not pass through the skin. To a certain extent, they accumulate in the tiny nooks and crannies of skin and slowly release the entrapped drug, as the skin needs it. The microspunge system can also avoid unnecessary accumulation of ingredients within the epidermis and the dermis. Potentially, they can reduce considerably the irritation of effective drugs without reducing their efficacy. These products are normally presented to the consumer in conventional forms like creams, gels, lotions, ointments, powders and share a broad package of benefits.

A microspunge delivery system (MDS) is highly cross-linked, patented, porous, polymeric microspheres that acquire the flexibility to entrap a wide variety of active ingredients such as emollients, fragrances, sunscreens, essential oils, anti-infective, anti-fungal and anti-inflammatory agents etc and are used as a topical carrier system<sup>3</sup>. Resembling a true sponge, each microsphere consists of an innumerable of interconnecting voids within a non-collapsible structure with a large porous surface. It is a unique technology for the controlled release of topical agents which consists of microporous beads normally 10-25 microns in diameter, loaded with active ingredients that is subsequently releases them onto the skin over a time in a controlled manner or in response to triggers including rubbing, pH, friction, moisture and ambient skin temperature. When it is applied to the skin, the drug release can be controlled through diffusion. This controlled release of active ingredient onto skin over time is an enormously important tool for providing the benefits of enhanced product efficacy, tolerability, mildness and lessen the irritation usually associated with powerful therapeutic agents like

retinoids or benzoyl peroxide and extended wear to a wide range of skin therapies<sup>4</sup>. This system has been utilized for the improvement of performance of topically applied drug. MDS technology is now being presently used in cosmetics, over-the-counter (OTC) skin care, sunscreens and prescription products.

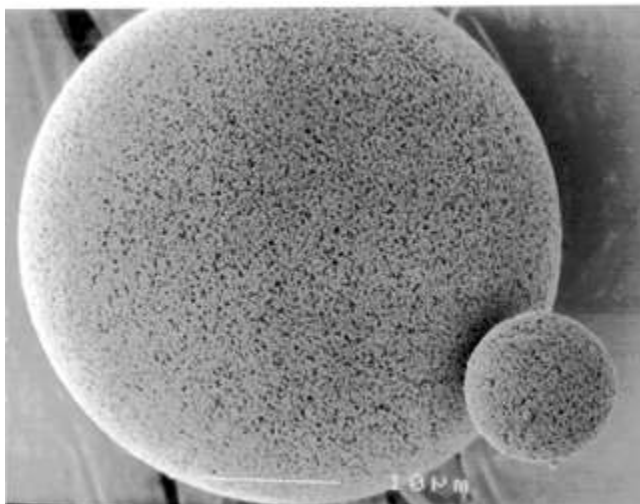

**Fig. 1: View of microspunge<sup>5</sup>.**

#### **Advantages of MDS<sup>6</sup>:**

- Microsponges can absorb oil up to 6 times its weight without drying.
- It provides continuous action upto 12 hours i.e. extended release.
- Improved product elegancey.
- Lessen the irritation and better tolerance leads to improved patient compliance.
- They have better thermal, physical and chemical stability.
- These are non-irritating, non-mutagenic, non-allergenic and non-toxic.
- MDS allows the incorporation of immiscible products.
- They have superior formulation flexibility.
- In contrast to other technologies like microencapsulation and liposomes, MDS has wide range of chemical stability, higher payload and are easy to formulate.
- Liquids can be converted in to powders improving material processing.
- It has flexibility to develop novel product forms.
- MDS can improve bioavailability of some drugs.
- It can also improve efficacy in treatment.

#### **Salient features of microsponges<sup>7</sup>:**

- MDS are stable over range of pH 1 to 11.
- These are stable at the temperature up to 130°C.
- These are compatible with the majority of vehicles and ingredients.
- Self sterilizing as their average pore size is 0.25µm where bacteria cannot penetrate.
- These systems have higher payload upto 50 to 60%.
- These are free flowing and can be cost effective.

**Characteristics of actives that is entrapped into microsponges<sup>8</sup>:**

Active ingredients that are entrapped in microsponges can then be incorporated into many products such as creams, gels, powders, lotions and soaps. Certain considerations are taken into account while, formulating the vehicle in order to achieve desired product characteristics:

- It should be either fully miscible in monomer as well as capable of being made miscible by addition of small amount of a water immiscible solvent.
- It should be inert to monomers and should not increase the viscosity of the mixture during formulation.
- It should be water immiscible or nearly only slightly soluble.
- It should not collapse spherical structure of the microsponges.
- It should be stable in contact with polymerization catalyst and also in conditions of polymerization.
- The solubility of actives in the vehicle must be limited. If not, the vehicle will deplete the microsponges before the application.
- Not more than 10 to 12% w/w microsponges must be incorporated into the vehicle in order to avoid cosmetic problems.
- Payload and polymer design of the microsponges for the active must be optimized for required release rate for given period of time.

**METHODS OF PREPARATION OF MICROSPONGES:**

Initially, drug loading in microsponges is mainly take place in two ways depending upon the physicochemical properties of drug to be loaded. If the drug is typically an inert non-polar material which will generate the porous structure then, it is known as porogen. A Porogen drug neither hinders the polymerization process nor become activated by it and also it is stable to free radicals is entrapped with one-step process (liquid-liquid suspension polymerization). Microsponges are suitably prepared by the following methods:

**Liquid-liquid suspension polymerization:**

Microsponges are prepared by suspension polymerization process in liquid-liquid systems (one-step process). Firstly, the monomers are dissolved along with active ingredients (non-polar drug) in an appropriate solvent solution of monomer, which are then dispersed in the aqueous phase with agitation. Aqueous phase typically consist of additives such as surfactants and dispersants (suspending agents) etc in order to facilitate the formation of suspension. Once the suspension is established with distinct droplets of the preferred size then, polymerization is initiated by the addition of catalyst or by increasing temperature as well as irradiation. The polymerization method leads to the development of a reservoir type of system that opens at the surface through pores. During the polymerization, an inert liquid immiscible with water however completely miscible with monomer is used to form the pore network in some cases. Once the polymerization process is complete, the liquid is removed leaving the microsponges which is permeate within preformed microsponges then, incorporates the variety of active substances like anti fungal, rubefaciants, anti acne, anti inflammatory etc and act as a topical carriers. In some cases, solvent

can be used for efficient and faster inclusion of the functional substances<sup>9</sup>. If the drug is susceptible to the condition of polymerization then, two-step process is used and the polymerization is performed by means of alternate porogen and it is replaced by the functional substance under mild conditions.

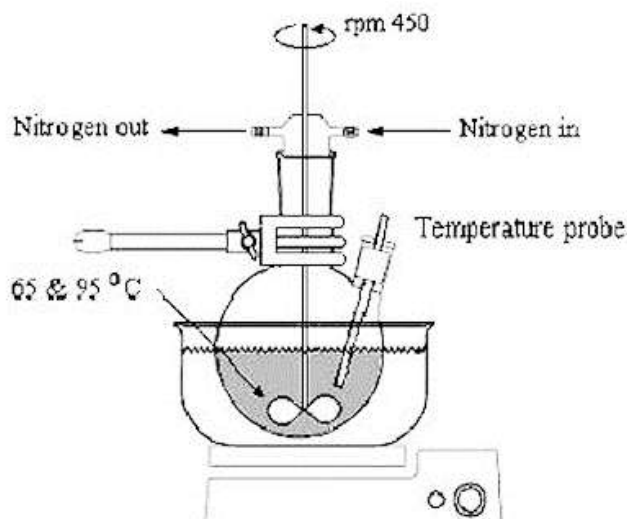

**Fig. 2: Reaction vessel for microsphere preparation by liquid-liquid suspension polymerization<sup>10</sup>.**

The various steps involved in the preparation of microspheres are summarized as follows:

- Step 1:** Selection of monomer as well as combination of monomers.
- Step 2:** Formation of chain monomers as polymerization starts.
- Step 3:** Formations of ladders as a result of cross-linking between chain monomers.
- Step 4:** Folding of monomer ladder to form spherical particles.
- Step 5:** Agglomeration of microspheres leads to the production of bunches of microspheres.
- Step 6:** Binding of bunches to produce microspheres.

#### **Quasi-emulsion solvent diffusion:**

Porous microspheres (microspheres) were also prepared by a quasi-emulsion solvent diffusion method (two-step process) using an internal phase containing polymer such as eudragit RS 100 which is dissolved in ethyl alcohol. Then, the drug is slowly added to the polymer solution and dissolved under ultrasonication at 35° C and plasticizer such as triethylcitrate (TEC) was added in order to aid the plasticity. The inner phase is then poured into external phase containing polyvinyl alcohol and distilled water with continuous stirring for 2 hours<sup>11</sup>. Then, the mixture was filtered to separate the microspheres. The product (microspheres) was washed and dried in an air-heated oven at 40 ° C for 12 hr<sup>12</sup>.

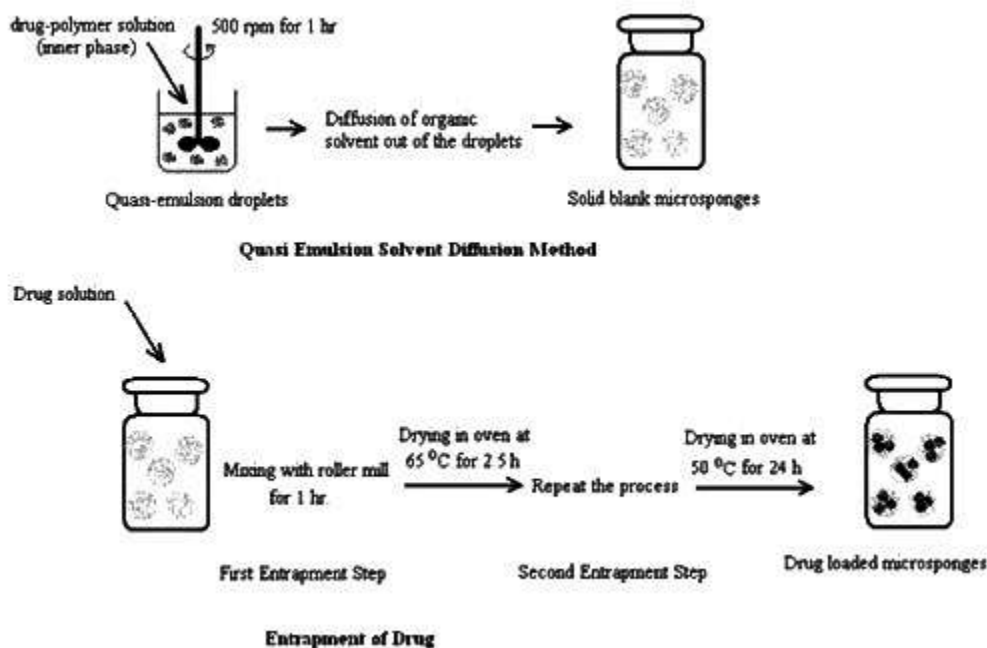

**Fig. 3: Method of quasi-emulsion solvent diffusion<sup>13</sup>.**

#### **DRUG RELEASE MECHANISM:**

Microsponges can be intended to release given amount of active ingredients over time in response to one or more following external triggers i.e. pressure, temperature change and solubility etc which are described as follows:

##### **Temperature change:**

At room temperature, few entrapped active ingredients can be too viscous to flow suddenly from microsponges onto the skin. With increase in skin temperature, flow rate is also increased and therefore release is also enhanced<sup>14</sup>.

##### **Pressure:**

Rubbing or pressure applied can release the active ingredient from microsponges onto skin<sup>14</sup>.

##### **Solubility:**

Microsponges loaded with water miscible ingredients like antiseptics and anti-perspirants will release the ingredient in the presence of water. The release can also be activated by diffusion but taking into consideration, the partition coefficient of the ingredient between the microsponges and the external system<sup>14</sup>.

#### **CHARACTERIZATION OF MICROSPONGES:**

##### **Particle size analysis:**

Particle size determination of loaded as well as blank microsponges can be carried out by laser light diffractometry or any other appropriate method. Values can be expressed for all the formulations in terms of mean size range. It can be studied by plotting cumulative % drug release from microsponges of different particle size against time to study effect of particle size on drug

release. Particles having sizes bigger than 30  $\mu\text{m}$  can impart grittiness and thus particles having sizes between 10 and 25  $\mu\text{m}$  are favored to be use in final topical formulation<sup>15</sup>.

#### **Determination of entrapment efficiency and production yield:**

The entrapment efficiency (%) of the microsponges can be calculated according to the following equation<sup>16</sup>:

Entrapment efficiency (%) = [Actual drug content/Theoretical drug content] X 100

The production yield of the microsponges can be obtained by calculating accurately the initial weight of the raw materials and the last weight of the microspunge obtained.

Production yield = [Practical mass of microsponges/Theoretical mass (polymer + drug)] X 100

#### **Morphology and surface topography of microsponges:**

The internal and external morphology and surface topography can be studied by scanning electron microscopy (SEM). Prepared microsponges can be coated with gold–palladium under an argon atmosphere at room temperature and then SEM images of microsponges were recorded at the required magnification. SEM of a fractured microspunge particle can also be taken to illustrate its ultra structure<sup>17</sup>.

#### **Characterization of pore structure:**

Pore volume and pore diameter are critical in controlling the intensity as well as duration of effectiveness of the active ingredient. Pore diameter can also affects the passage of active ingredients from microsponges into the vehicle in which the material is dispersed. The effect of pore diameter as well as volume with rate of drug release from microsponges can be studied by mercury intrusion porosimetry. Porosity parameters of microsponges such as intrusion–extrusion isotherms, total pore surface area, pore size distribution, average pore diameters, shape and morphology of the pores, bulk and apparent density can also be determined by using mercury intrusion porosimetry<sup>17</sup>.

#### **Determination of true density:**

The true density of microsponges was measured by an ultra-pycnometer under helium gas and was calculated from a mean of repeated determinations<sup>18</sup>.

#### **Polymer/ Monomer composition:**

Various factors such as microsphere size, polymer composition and drug loading govern the drug release from microspheres. Polymer composition can also influence the partition coefficient of the entrapped drug between the microspunge system and the vehicle and thus have direct affect on the rate of release of entrapped drug. Drug release from microspunge systems of different polymer compositions can be studied by plotting cumulative % drug release against time. The choice of monomer is dictated both by the vehicle into which it will be dispersed and characteristics of active ingredient to be entrapped. Polymers with varying degrees of hydrophobicity or lipophilicity or electrical charges may be prepared to give flexibility in the release of active ingredients. A variety of probable monomer combinations will be screened for their appropriateness with drugs by studying their drug release profile<sup>18</sup>.

**Compatibility studies:**

Fourier Transform Infra-red spectroscopy (FT-IR) and thin layer chromatography (TLC) was performed to study the compatibility of drug with reaction adjuncts. Effect of polymerization on crystallinity of the drug can be studied by powder X-ray diffraction (XRD) and Differential scanning calorimetry (DSC). For DSC, approximately 5mg samples can be weighed accurately into aluminum pans, then sealed and can be run at a heating rate of 15 °C/min over a temperature range 25–430 °C in atmosphere of nitrogen<sup>19</sup>.

**Resiliency:**

Viscoelastic properties (resiliency) of microsponges can be tailored to create beadlets which is softer or firmer according to the requirements of the final formulation. Increased crosslinking tends to slow down the release rate. Therefore, resiliency of microsponges will be performed and optimized as per the prerequisite by considering release as a function of crosslinking with time<sup>19</sup>.

**In-vitro release studies:**

*In-vitro* release studies have been carried out using dissolution apparatus USP XXIII equipped with a modified basket consisted of 5µm stainless steel mesh. Dissolution rates were measured at 37 °C under 150 rpm rotor speed. The dissolution medium is selected while considering solubility of active ingredients to ensure sink conditions. Sample aliquots were withdrawn from the dissolution medium and analyzed by suitable analytical method (UV spectrophotometer) at regular intervals of time<sup>20</sup>.

**SAFETY CONSIDERATION<sup>21, 22</sup>:**

Safety studies of microsponges can be established by:

- Eye irritation studies in rabbits.
- Skin irritation studies in rabbits.
- Mutagenicity in bacteria.
- Oral toxicity studies in rats.
- Allergenicity in guinea pigs.

**APPLICATIONS OF MICROSPONGE SYSTEM:**

Microsponges are used mostly for topical delivery and recently for oral as well as biopharmaceutical delivery. It offers the formulator a range of alternatives to develop drug and cosmetic products. Microsponges are designed to deliver a pharmaceutical active ingredient efficiently at the minimum dose and also to enhance stability, reduce side effects and modify drug release.

**Microsponge for topical delivery:**

Benzoyl peroxide (BPO) is mainly used in the treatment of mild to moderate acne and athlete's foot and the most common side effect associated with BPO is skin irritation and it has been shown that controlled release of BPO from a delivery system to the skin could lessen the side effect while reducing percutaneous absorption. Topical delivery system with reduced irritancy was successfully developed<sup>23</sup>.



Nokhodchi *et al*<sup>24</sup> studied factors affecting the morphology of benzoyl peroxide (BPO) microsponges. It has been revealed that encapsulation and controlled release of BPO can lessen the side effect while, when administered to the skin it also reduces percutaneous absorption. The goal of the study was to design and formulate a suitable encapsulated form of BPO using microsphere technology and investigate the parameters affecting the morphology and other characteristics of the resulting products with the help of scanning electron microscopy (SEM). Benzoyl peroxide particles were prepared by an emulsion solvent diffusion method by including an organic internal phase containing benzoyl peroxide, dichloromethane and ethyl cellulose into a stirred aqueous phase containing polyvinyl alcohol (PVA). Different concentrations of BPO microsponges were incorporated in lotion formulations and the drug release from these formulations were studied. The SEM micrographs of the BPO microsponges used for the measurement of their size and showed that they were porous and spherical. Results showed that the morphology and particle size of microsponges were affected by drug: polymer ratio, amount of emulsifier used and stirring rate. The results obtained also showed that with increase in the ratio of drug: polymer resulted in a reduction in the rate of release of BPO from the microsponges. The release data showed that the highest and the lowest release rates were obtained from lotions containing plain BPO particles and BPO microsponges with the drug: polymer ratio (13:1) respectively. Kinetics studies showed that the release data followed peppas model but diffusion was the main mechanism of drug release from BPO microsponges.

Amrutiya *et al*<sup>25</sup> developed microsphere based topical delivery system of mupirocin by an emulsion solvent diffusion method and evaluated for sustained release and enhanced drug deposition in the skin. The effect of formulation and process variables like stirring speed and internal phase volume on the physical characteristics of microsponges was analyzed on optimized drug/polymer ratio by 3<sup>2</sup> factorial design. The optimized microsponges were incorporated into an emulgel base. Several parameters were studied i.e. *in-vitro* drug release, *ex-vivo* drug deposition and *in-vivo* antibacterial activity of mupirocin-loaded formulations. Prepared microsponges were spherical and porous and found no interaction between drug and polymer molecules. Emulgels containing microsponges were showed preferred physical properties. Diffusion-controlled release pattern were showed by drug release through cellulose dialysis membrane and drug deposition studies using rat abdominal skin has been exhibited significant retention of actives in skin from microsphere based formulations by 24 h. Draize patch test demonstrated that the optimized formulations were stable and nonirritant to skin. Microsponges based emulgel formulations showed extended efficacy in mouse surgical wound model infected with *S. aureus*. Mupirocin was stable in topical emulgel formulations and showed enhanced retention in the skin demonstrating superior potential of the delivery system for the treatment of primary and secondary skin infections i.e. eczema, impetigo and atopic dermatitis.

D'souza *et al*<sup>26</sup> studied topical anti-inflammatory gels of fluocinolone acetonide entrapped in eudragit based microsphere delivery system. Fluocinolone acetonide (FA) is a corticosteroid chiefly used in dermatology to lessen skin inflammation and relieve itching. The percutaneous

absorption increases risk related with systemic absorption of topically applied formulation. Thus, the goal of the study was to produce FA entrapped microsponges which were prepared by quasi-emulsion solvent diffusion method in order to control the release of drug to the skin which in turn lessens the side effect whereas also reducing percutaneous absorption. FT-IR and DSC was done to study the compatibility of drug with reaction adjuncts. Several parameters like particle size analysis, loading efficiency, Production yield and surface morphology of microsponges were performed. Microparticles were then incorporated into carbopol 934 gels into standard vehicles for release and comparative anti-inflammatory studies were performed. FT-IR and DSC studies showed that there is no incompatibility between formulation adjuvants and process parameters. Surface morphology can be done by scanning electron microscopy (SEM) which showed microporous nature of microsponges. Drug release was also observed controlled with comparative anti-inflammatory activity with the gels that contains free drug.

Grimes *et al*<sup>27</sup> studied micro sponge formulation of hydroquinone 4% and retinol 0.15% in the treatment of melasma and postinflammatory hyperpigmentation. Hyperpigmentation is mainly characterized by disorders like melasma and postinflammatory hyperpigmentation which is particularly common among people with darker skin types. Hydroquinone (HQ) bleaching creams are generally considered as the gold standard for treating hyper pigmentation. The aim of the study is to develop a formulation of HQ 4% with retinol 0.15% entrapped in micro sponge reservoirs to release HQ slowly to extend exposure to treatment and also to minimize skin irritation. This product was evaluated in a 12-week open-label study for safety and efficacy. A total of 28 patients were enrolled but 25 patients completed the study. End points of study included pigmentation intensity, disease severity, lesion area and colorimetry assessments. Adverse events were also recorded. Patients can applied the micro sponge formulation entrapped HQ 4% to the full face in morning and evening (twice) daily. After 15 minutes of application of the test product, a broad-spectrum sunscreen was applied once in the morning. Then, Patients were evaluated at baseline and at 4, 8, and 12 weeks. The study showed that microentrapped HQ 4% with retinol 0.15% formulation produced improvement at all study end points. Microentrapped HQ 4% was well tolerated but only one patient discontinuing due to an allergic reaction which was not considered serious. The open-label study concluded that microentrapped HQ 4% with retinol 0.15% was safe and effective.

**Table 1: Applications of microsponge system<sup>28</sup>**

S. No.	Active agents	Applications
1.	Anti-inflammatory e.g. hydrocortisone	Long lasting activity with lessening of skin allergic response and dermatoses.
2.	Anti-dandruffs e.g. zinc pyrithione, selenium sulfide	Reduced unpleasant odor with reduced irritation with extended efficacy and safety.
3.	Skin depigmenting agents e.g. hydroquinone	Improved stabilization against oxidation with improved efficacy and aesthetic appeal.
4.	Anti-fungals	Sustained release of actives.
5.	Anti-acne e.g. Benzoyl peroxide	Maintained efficacy with reduced skin irritation and sensitization.
6.	Antipruritics	Extended and improved activity.
7.	Sunscreens	Long lasting product efficacy with improved protection against sunburns and sun related injuries even at elevated concentration and with reduced irritancy and sensitization.
8.	Rubefaciants	Prolonged activity with reduced irritancy, greasiness and odor.

**Microsponge for oral delivery:**

A Microsponge system offers the potential for active ingredients to remain within a protected environment and provide controlled delivery of oral medication to the lower gastrointestinal (GI) tract, where it will be released upon exposure to specific enzymes in the colon. If this approach is successful then it should open up entirely new opportunities for MDS. It has been shown that microsponge system enhances the solubilization of drugs which are poorly soluble by entrapping these drugs in their pores. As these pores are very small, the drug is in effect reduced to microscopic particles and drastically increased surface area consequently, increases the rate of solubilization. Additionally, the time it takes the microsponge system to pass through the small and large intestine is considerably increased as a result maximizing the amount of drug that is absorbed.

Jain *et al*<sup>29</sup> prepared paracetamol loaded eudragit RS 100 based microsponges by quasi-emulsion solvent diffusion method. The compatibility of the drug with different formulation components was demonstrated. In order to optimize the formulation process parameters were analyzed. Surface morphology and shape of the microsponges were analyzed using scanning electron microscopy (SEM). Compression coating of microsponges with pectin: HPMC mixture followed by tableting was used to prepare colon specific formulations. The *in-vitro* drug release studies were done on all the formulations and the results were evaluated kinetically and statically. The

study concluded that the release data followed Higuchi matrix but diffusion was the main mechanism of drug release from microsponges. *In-vitro* studies showed that compression coated colon specific tablet formulations started the release of drug at the 6th hour resultant to the arrival time to proximal colon.

Gonul *et al*<sup>30</sup> studied the effects of pressure and direct compression on tableting of microsponges. In the study, ketoprofen was used as a model drug for systemic drug delivery of microsponges. ketoprofen microsponges were prepared by quasi-emulsion solvent diffusion method with eudragit RS 100 and tablets of microsponges were prepared by direct compression method. In order to determine the optimum pressure value for the compression of the tablets, different pressure values were applied to the tablet powder mass. Results of the study indicated that microsphere compressibility was much better over the physical mixture of the drug and polymer and due to the plastic deformation of sponge-like structure; microsponges can produce mechanically strong tablets.

Jain *et al*<sup>31</sup> studied dicyclomine loaded eudragit based microsphere with potential for colonic delivery. The aim of the study was to prepare dicyclomine loaded eudragit based microspheres by means of a quasi-emulsion solvent diffusion method. Differential scanning calorimetry (DSC) and fourier transform infra-red (FTIR) was done to study the compatibility of the drug with various formulation components. Process parameters were modulated in order to optimize the formulation. Surface morphology and shape of the microspheres were demonstrated using scanning electron microscopy (SEM). The consequences of compatibility studies showed that there is no chemical interaction took place throughout the preparation of the formulations; also the drug was stable in all the formulations. A reduction in the release rate of the drug from the microspheres with increase in drug: polymer ratio. Kinetic studies showed that the Higuchi matrix controlled diffusion was the main mechanism of drug release. With an initial burst effect, the drug release was bi-phasic with 16 – 30 % of the drug was released in the 1<sup>st</sup> hour. Cumulative release for the microspheres over 8 hours was ranged from 59 - 86 %. This study concluded an approach for the alteration of microspheres of dicyclomine for prolonged drug release. The distinctive compressibility of microspheres can be applied to get efficient local action as microspheres may be taken up by macrophages which are present in colon.

Cevher *et al*<sup>32</sup> were designed and evaluated colon specific drug delivery system containing flurbiprofen (FLB) microspheres. The main aim of this study was to prepare microspheres containing FLB and eudragit RS 100 by quasi-emulsion solvent diffusion method. Moreover, FLB was entrapped into a commercial Microsphere<sup>®</sup> 5640 system by means of entrapment method. Then, the effects of drug: polymer ratio, amount of inner phase solvent, stirring speed and time and stirrer type on the physical characteristics of microspheres was examined. The surface morphology, thermal behaviour, pore structure and particle size of microspheres were investigated. Compression coating and pore plugging of microspheres with pectin: HPMC mixture followed by tableting was used to prepare colon specific formulations. The *in-vitro* drug release studies were done on all the formulations and the results were evaluated kinetically and

stastically. The microsponges were spherical in shape and found to be in between 30.7 and 94.5  $\mu\text{m}$  in diameter and showed high porosity values i.e. 61–72%. The pore shapes of microsponges prepared by quasi-emulsion solvent diffusion method were found as spherical whereas by entrapment method it was found as cylindrical holes. Due to the plastic deformation of sponge-like structure of microsponges, mechanically strong tablets were produced for colon specific drug delivery. In vitro studies revealed that colon specific tablet formulations prepared by compression coating, started to release the drug at the 8th hour resultant to the proximal colon arrival time due to the addition of enzyme which could followed a modified release pattern whereas the drug release from the colon specific formulations prepared by pore plugging the microsponges showed an increase at the 8th hour which was the time point that the enzyme addition was made. This study brings a new concept based on microsponges for colon specific drug delivery.

#### **Microsponges for biopharmaceuticals delivery:**

The microsphere delivery system (MDS) is employed for both in the delivery of biopharmaceuticals as well as in tissue engineering.

Matsuda *et al*<sup>33</sup> has been studied the biodegradable polymer with collagen microsphere serves as a new bioengineered cardiovascular prosthesis. Biodegradable materials with autologous cell seeding had gaining much interest as potential cardiovascular grafts. Though, pretreatment of biodegradable materials require an invasive and complicated procedure that carries the risk of infection. The main aim of the study is to develop a biodegradable graft material containing collagen microsphere that would allow the regeneration of autologous vessel tissue in order to avoid these problems. The capability of this material to hasten in situ cellularization with autologous endothelial and smooth muscle cells was tested with and without pre-cellularization. Poly (lactic-co-glycolic acid) has been used as a biodegradable scaffold which was compounded with collagen microsphere to form a vascular patch material. The poly (lactic-co-glycolic acid)–collagen patches with or without autologous vessel cellularization were used to patch the canine pulmonary artery trunk. Biochemical and histologic assessments were performed 2 and 6 months after the implantation. The results showed that there was no thrombus formation in either group but the poly (lactic-co-glycolic acid) scaffold was approximately completely absorbed in both groups. Histologic results showed the formation of an endothelial cell monolayer, a parallel alignment of smooth muscle cells, and reconstructed vessel wall with elastin and collagen fibers. The cellular and extra-cellular components in the patch had enlarged to levels analogous to those in native tissue at 6 months. The study concluded that poly (lactic-co-glycolic acid) collagen microsphere patch with and without pre-cellularization showed good histologic result and durability. This patch also shows promise as a bioengineered material for promoting in situ cellularization and the regeneration of autologous tissue in cardiovascular surgery.

Tabata *et al*<sup>34</sup> has been studied type I collagen can function as a reservoir of basic fibroblast growth factor. Several endogenous growth factors which are stored and release by the

extracellular matrix (ECM) are significant biological events that can control tissue homeostasis and regeneration. The interaction between heparin sulfate proteoglycans and basic fibroblast growth factor (bFGF) has been widely studied and can be used as a prototype model for such system whereas the fibrillar type I collagen which has lower affinity for bFGF has been considered biologically insignificant. bFGF suddenly interacts with type I collagen solution as well as sponges under in vitro and in vivo conditions and it is also protected from the proteolytic environment by the collagen. bFGF incorporated in a collagen sponge sheet was released sustainedly in the mouse sub-cutis according to the biodegradation of the sponge matrix and can exhibited local angiogenic activity in a dose-dependent manner. The study showed that i. m. injection of collagen microsponges incorporating bFGF induced a considerable increase in the blood flow in the murine ischemic hind limb which could never been attained by bolus injection of bFGF. These results concluded the significance and therapeutic utility of type I collagen as a reservoir of bFGF.

Chen *et al*<sup>35</sup> has been studied culturing of skin fibroblasts in a thin PLGA–collagen hybrid mesh. A thin biodegradable hybrid mesh of synthetic poly (DL-lactic-co-glycolic acid) (PLGA) and naturally derived collagen was used for three-dimensional culture of human skin fibroblasts. The hybrid mesh can be formed by utilizing web-like collagen microsponges in the openings of a PLGA knitted mesh. A comparison was done for the behaviors of the fibroblasts on the hybrid mesh and PLGA knitted mesh. This comparison showed that the efficiency of cell seeding was much higher and the cells grew more rapidly in the hybrid mesh as compared to the PLGA mesh. The fibroblasts in the hybrid mesh grew from the collagen microsponges in the openings of the mesh resulting in a more homogenous growth whereas those in the PLGA mesh also grew from the peripheral PLGA fibers toward the centers of the openings. In the hybrid mesh, the proliferated cells and secreted extracellular matrices were more consistently distributed as compared to the PLGA mesh. Histological staining of in vitro cultured fibroblast or mesh implants showed that the fibroblasts were uniformly distributed throughout the hybrid mesh and produced a homogeneous layer of dermal tissue having nearly the same thickness as that of the hybrid mesh. Though, the tissue which was formed in the PLGA mesh was thick adjacent to the PLGA fibers and thin in the center of the openings. Fibroblasts cultured in the hybrid mesh were implanted in the back of nude mouse. After 2 weeks, dermal tissues were formed and became epithelialized after 4 weeks. The study concluded that the efficiency of cell seeding, better cell distribution and consequently facilitated quick formation of dermal tissue having a uniform thickness has been increased by web-like collagen microsponges formed in the openings of the PLGA knitted mesh. PLGA–collagen hybrid mesh may possibly be valuable for skin tissue engineering.

Chen *et al*<sup>36</sup> has also been studied development of biodegradable porous scaffolds for tissue engineering. Three-dimensional biodegradable porous scaffolds play a vital role in tissue engineering. A novel method of preparing porous scaffolds which consists of synthetic biodegradable polymers was developed by combining porogen leaching and freeze-drying

techniques utilizing preprepared ice particulates as the porogen material. The pore structures of the polymer sponges could be manipulated by controlling processing variables like the polymer concentration and the size and weight fraction of the ice particulates. Biodegradable hybrid porous sponges of synthetic polymer and collagen have been prepared by hybridizing synthetic polymer sponges with collagen microsponges. The collagen microsponges were produced in the pores of synthetic polymer sponges. The hybrid porous sponges acquire the advantages of synthetic polymers and collagen both. Hybrid sponges of synthetic polymer, collagen and inorganic hydroxyapatite were prepared by depositing hydroxyapatite particulates on the surfaces of the collagen microsponges in the synthetic polymer–collagen sponges. The synthetic polymer sponge were used as a mechanical skeleton to aid the formation of these hybrid sponges into desired shapes and contributed good mechanical strength and handling whereas the collagen and hydroxyapatite are used to promote cell interaction and facilitate cell seeding.

#### **PATENTS INFORMATION:**

In September 1, 1987, Won R (Palo Alto, CA) of Advanced Polymer Systems, Inc. (Redwood City, CA) received (United States Patent 4,690,825) for developing method to deliver an active ingredient by controlled time release using a novel delivery vehicle that can be prepared by a process utilizing the active ingredient as a porogen<sup>37</sup>.

In September 8, 1992, Won R (Palo Alto, CA) of Advanced Polymer Systems, In (Redwood City, CA) received (United States Patent 5,145,675) for developing a two-step method for the preparation of controlled release formulations<sup>38</sup>.

Advanced Polymer Systems, Inc. and subsidiaries ("APS" or the "Company") is using its patented microsphere(R) delivery systems and related proprietary technologies to increase the safety, aesthetic quality and effectiveness of topical prescription, over-the-counter ("OTC") and personal care products like Vitamin- A, tretinoin and 5-fluorouracil etc. As on July 23, 2006, the Company has a total of 10 issued U.S. patents and an additional 92 issued foreign patents. 21 patent applications are pending worldwide.

Dean JR *et al*<sup>39</sup> received US patent no. 4863856 for the development of weighted collagen microsponges having a highly cross-linked collagen matrix that is suitable for use in culturing organisms in motive reactor systems. The microsponges have an open to the surface pore structure, pore volumes and pore sizes suitable for immobilizing a range of bioactive materials.

#### **MARKETED FORMULATIONS:**

MDS is best for skin and personal care products. They can take up large amounts of excess of skin oil while retaining an elegant feel on the surface of skin. This technology is presently employed in approximately number of products sold by leading cosmetic and toiletry companies worldwide. Among these products include moisturizers, skin cleansers, deodorants, oil control lotions, conditioners, razors, lipstick, powders, makeup and eye shadows which offers various advantages including improved physical and chemical stability, greater available concentrations, reduced skin irritation and sensitization and controlled release of the active ingredients and unique tactile qualities.

**Table 2: Marketed formulations of microsponges<sup>40, 41</sup>**

S. No	Product name	Manufacturer	Advantages
1.	Carac Cream	Dermik Laboratories, Inc. Berwyn, PA 19312 USA	Carac Cream contains 0.5% fluorouracil; with 0.35% being incorporated into a patented porous microsphere consisted of methyl methacrylate / glycol dimethacrylate cross-polymer and dimethicone. Carac is a once-a-day topical prescription product for the treatment of actinic keratosis (AK) that is characterized by common pre-cancerous skin condition caused by over-exposure to the sun.
2.	Retin-A-Micro	Ortho-McNeil Pharmaceutical, Inc.	Retin-A-Micro contains 0.1% and 0.04% tretinoin entrapped into a patented porous microsphere consisted of methyl methacrylate/ glycol dimethacrylate cross-polymer to enable inclusion of the active ingredient, tretinoin, in an aqueous gel. This formulation is used for the topical treatment of acne vulgaris.
3.	Salicylic Peel 20 & 30	Biophora	Salicylic acid 20%, microsphere technology has excellent exfoliation and used for stimulation of the skin for more resistant skin types or for faster results. It will considerably improve pigmentation, fine lines and acne concerns. Salicylic acid moves easily through the pores, clearing them out while reducing inflammation. This treatment effectively combats acne leaving an amazingly smooth and clear complexion.
4.	Line Eliminator Dual Retinol Facial Treatment	Avo n	Lightweight cream with a retinol (Vitamin A) in MDS, dual-system delivers both immediate and time released wrinkle-fighting action. Clearly diminishes appearance of fine lines, wrinkles & skin discolorations associated with aging.



5.	Micro Peel Plus /Acne Peel	Biomedic	The MicroPeel ® Plus procedure stimulates cell turnover through the application of salicylic acid in the form of microcrystals using Microsponge ® technology. These microcrystals target the exact areas on the skin that need improvement. The MicroPeel Plus aggressively outperforms other superficial chemical peels by freeing the skin of all dead cells while doing no damage to the skin.
6.	Retinol cream, Retinol 15 Night cream	Biomedic, Sothys	A night time treatment cream with Microsponge technology using a stabilized formula of pure retinol, Vitamin A. Continued use of Retinol 15 will result in the visible diminishment of fine lines and wrinkles, a noticeable improvement in the skin discolorations due to aging, and enhanced skin smoothness.
7.	Lactrex™ 12% Moisturizing Cream	SDR Pharmaceuticals, Inc., Andover , NJ , U.S.A. 07821	Lactrex™ 12% Moisturizing Cream contains 12% lactic acid as the neutral ammonium salt, ammonium lactate. Microsponge® technology has been included for easy application and long lasting moisturization. Lactrex™ also contains water and glycerin, a natural humectant to soften and help moisturize dry, flaky, cracked skin.
8.	EpiQuin Micro	SkinMedica Inc	The Microsponge® system uses microscopic reservoirs that entrap hydroquinone and retinol. The microsponges release these ingredients into the skin gradually throughout the day. This provides the skin with continuous exposure to hydroquinone and retinol over time, which may minimize skin irritation. EpiQuin Micro is a

			prescription moisturizing fading cream that reduces the impact of these conditions known as melasma, post inflammatory hyper pigmentation or solar lentigines. Also help in Age spots, Sun spots and Facial discoloration.
9.	Oil free matte block spf20	Dermalogica	This invisible oil-free sunscreen shields the skin from damaging UV sun rays while controlling oil production, giving you a healthy matte finish. Formulated with microsponge technology, Oil free matte block absorbs oil and preventing shine without any powdery residue.
10.	Sportscream RS and XS	Embil Pharmaceutical Co. Ltd.	Topical analgesic-anti-inflammatory and counterirritant actives in a microsponge® delivery system (MDS) for the management of musculoskeletal conditions.
11.	Oil Control Lotion	Fountain Cosmetics	A feature-light lotion with technically advanced microsponges that absorb oil on the skin's surface during the day, for a matte finish. Eliminate shine for hours with this feature-weight lotion, formulated with oil-absorbing Microsponge technology. The naturally-antibiotic Skin Response Complex soothes inflammation and tightness to promote healing. Acne-Prone, oily skin conditions.
12.	Ultra Guard	Scott Paper Company	Microsponge system that contains dimethicone to help protect a baby's skin from diaper rash. The new wipe contains a skin protectant that helps keep wetness and irritants from the baby's skin. The solution is alcohol-free, hypoallergenic and contains dimethicone, an ingredient found in baby creams, lotions and skin protectants.

13.	Aramis fragrances	Aramis Inc.	24 hour high performance antiperspirant spray sustained release of fragrance in the microsp sponge. The microsp sponge comes in the form of an ultra light powder, and because it is micro in size, it can absorb fragrance oil easily while maintaining a free-flowing powder characteristic where release is controlled due to moisture and temperature.
-----	-------------------	-------------	--

### **FUTURE PROSPECTS:**

MDS holds a promising future in various pharmaceutical applications in the coming years as they have unique properties like enhanced product performance and elegance, extended release, reduced irritation, improved physical, chemical, and thermal stability so flexible to develop novel product forms. MDS which is originally developed for topical delivery of drugs like anti-acne, anti-inflammatory, anti-fungal, anti-dandruffs, antipruritics, rubefaciants etc. The real challenge of microsp sponge delivery system in future is gaining for the advance core/shell delivery of the drug loaded microsponges for oral peptide delivery by varying ratio of polymers. Now a day it can also be used for controlled oral delivery of drugs using bioerodible polymers for colon specific delivery and also used for biopharmaceutical delivery as well as in tissue engineering. New classes of pharmaceuticals, biopharmaceuticals (peptides, proteins and DNA-based therapeutics) are fueling the rapid evolution of drug delivery technology.

### **CONCLUSION:**

MDS has become highly competitive and rapidly evolving technology and more and more research are carrying out to optimize cost-effectiveness and efficacy of the therapy. It is a unique technology for the controlled release of topical agents and consists of microporous beads loaded with active agent and also use for oral as well as biopharmaceutical drug delivery. Microsp sponge delivery systems that can precisely control the release rates or target drugs to a specific body site have a vast impact on the health care system. A microsp sponge delivery system can release its active ingredient on a time mode and also in response to other stimuli. Therefore, microsp sponge has got a lot of potential and is a very emerging field which is needed to be explored. Microsponges constitute a significant part by virtue of their small size and efficient carrier characteristics.

### **ACKNOWLEDGEMENTS:**

The authors are thankful to the Chairman of MIET Meerut for providing the necessary library and internet facilities.

**REFERENCES:**

1. Kydonieus AF, Berner B, Transdermal delivery of drugs. Boca Raton, CRC Press, 1987.
2. Chowdary KPR, Rao YS, Mucoadhesive microspheres for controlled drug delivery, Biol Pharm Bull, 27, 2004, 1717-1724.
3. Embil K, Nacht S, The microsphere delivery system (MDS): A topical delivery system with reduced irritancy incorporating multiple triggering mechanisms for the release of actives, J Microencapsul, 13, 1996, 575-588.
4. Delattre L, Delneuve I, Biopharmaceutical aspects of the formulation of dermatological vehicles, J Eur Acad Dermatol Venereol, 5, 1995, 70-71.
5. <http://www.microsphere.com/images/microsphereparticle.jpg>
6. Vyas SP, Khar RK, Targeted and Controlled Drug Delivery, 1st Ed, CBS Publication, 2002.
7. Aritomi H, Yamasaki Y, Yamada K, Honda H, Koshi M, Development of sustained release formulation of chlorpheniramine maleate using powder coated microspheres prepared by dry impact blending method, J Pharm Sci Tech, 56, 1996, 49-56.
8. Kawashima Y, Niwa T, Takeuchi H, Hino T, Itoh Y, Control of prolonged drug release and compression properties of ibuprofen microspheres with acrylic polymer, eudragit RS, by changing their intraparticle density, Chem Pharm Bull, 40, 1992, 196-201.
9. Hainey P, Huxham IM, Rowatt B, Sherrington DC, Synthesis and ultrastructural studies, of styrene-divinylbenzene polyhipe polymers, Macromolecules, 24, 1991, 117-121.
10. [http://www.pharmainfo.net/files/images/stories/article\\_images/ReactionVesselForMicrospherePreparation.jpg](http://www.pharmainfo.net/files/images/stories/article_images/ReactionVesselForMicrospherePreparation.jpg)
11. Shah VP, Elkins J, Lam S, Skelly JP, Determination of in vitro drug release from hydrocortisone creams, Int J Pharm, 53, 1989, 53-59.
12. Comoglu T, Gonul N, Baykara T, Preparation and in vitro evaluation of modified release ketoprofen microspheres, II Farmaco, 58, 2003, 101-106.
13. [http://www.pharmainfo.net/files/images/stories/article\\_images/PreparationOfMicrospheres.jpg](http://www.pharmainfo.net/files/images/stories/article_images/PreparationOfMicrospheres.jpg)
14. Khopade AJ, Jain S, Jain NK, The microsphere, Eastern Pharmacist, 1996, 49-53.
15. Martin AN, Swarbrick J, Cammarrata A, Physical pharmacy: Physical chemical principles in pharmaceutical sciences, 3rd Edn, Lea & Febiger (Philadelphia) publisher, 1983, 664.
16. Kilicarslan M, Baykara T, The effect of the drug/polymer ratio on the properties of verapamil Hcl loaded microspheres, Int J Pharm, 252, 2003, 99-109.
17. Emanuele AD, Dinarvand R, Preparation, characterization and drug release from thermo responsive microspheres, Int J Pharm, 118, 1995, 237-242.
18. Barkai A, Pathak YV, Benita S, Polyacrylate (Eudragit retard) microspheres for oral controlled release of nifedipine. Formulation design and process optimization, Drug Dev Ind Pharm, 16, 1990, 2057-2075.

19. D'souza JI, The microsphere drug delivery system: For delivering an active ingredient by controlled time release, *Pharmainfo.net*, 6, 2008, 62.
20. D'souza JI, In-vitro antibacterial and skin irritation studies of microsponges of benzoyl peroxide, *Indian Drugs*, 38, 2001, 361-362.
21. Sato T, Kanke M, Schroeder G, Deluca PP, Porous biodegradable microspheres for controlled drug delivery. I: Assessment of processing conditions and solvent removal techniques, *Pharm Res*, 5, 1988, 21 -30.
22. Draize JH, Woodard G, Calvery HO, Methods for the study of irritation and toxicity of substances applied topically to the Skin and Mucous Membranes, *J Pharmacol Exp Ther*, 82, 1944, 377-389.
23. D'souza JI, Jagdish K, Saboji, Suresh G, Killedar, Harinath N, Design and evaluation of benzoyl peroxide microsponges to enhance therapeutic efficacy in acne treatment, Accepted for presentation in 20<sup>th</sup> FAPA congress, Bangkok, 2004.
24. Nokhodchi A, Jelvehgari M, Siahi M, Mozafari M, Factors affecting the morphology of benzoyl peroxide microsponges, *Micron*, 38, 2007, 834-840.
25. Amrutiya N, Bajaj A, Madan M, Development of microsponges for topical delivery of mupirocin, *AAPS Pharm Sci Tech*, 10, 2009, 402-408.
26. D'souza JI, Harinath NM, Topical anti-inflammatory gels of fluocinolone acetonide entrapped in eudragit based microsphere delivery system, *Research J Pharm and Tech*, 1, 2008, 502-506.
27. Grimes PE, A microsphere formulation of hydroquinone 4% and retinol 0.15% in the treatment of melasma and post-inflammatory hyperpigmentation, *Cutis*, 74, 2004, 362-368.
28. Yazici E, Kas HS, Hincal AA, Microsponges. *Farmasotik Bilimler Dergisi (Turkey)*, 19, 1994, 121-128.
29. Jain V, Singh R, Development and characterization of eudragit RS 100 loaded microsponges and its colonic delivery using natural polysaccharides, *Acta Poloniae Pharmaceutica- Drug Research*, 67, 2010, 407-415.
30. Comoglu T, Gonul N, Baykara T, The effects of pressure and direct compression on tableting of microsponges, *Int J Pharm*, 242, 2002, 191-195.
31. Jain V, Singh R, Dicyclomine loaded eudragit based microsphere with potential for colonic delivery: Preparation and characterization, *Trop J Pharm Res*, 9, 2010, 67-72.
32. Orlu M, Cevher E, Araman A, Design and evaluation of colon specific drug delivery system containing flurbiprofen microsponges, *Int J Pharm*, 318, 2006, 103-117.
33. Iwai S, Sawa Y, Ichikawa H, Taketani S, Uchimura E, Chen G, Hara M, Miyake J, Matsuda H, Biodegradable polymer with collagen microsphere serves as a new bioengineered cardiovascular prosthesis, *J Thorac Cardiovasc Surg*, 128, 2004, 472-479.

34. Kanematsu A, Marui A, Yamamoto S, Ozeki M, Hirano Y, Yamamoto M, Ogawa O, Komeda M, Tabata Y, Type I collagen can function as a reservoir of basic fibroblast growth factor, *J Control Release*, 99, 2004, 281-292.
35. Chen G, Sato T, Ohgusi H, Ushida T, Tateishi T, Tanaka J, Culturing of skin fibroblasts in a thin PLGA–collagen hybrid mesh, *Biomaterials*, 26, 2005, 2559-2566.
36. Tateishi T, Chen G, Ushida T, Biodegradable porous scaffolds for tissue engineering, *J Artif Organs*, 5, 2002, 77-83.
37. Won R, Method for delivering an active ingredient by controlled time release utilizing a novel delivery vehicle which can be prepared by a process utilizing the active ingredient as a porogen, US Patent 4690825, 1987.
38. Won R, Two step method for preparation of controlled release formulations, US Patent 5145675, 1992.
39. Dean JR, Robert C, Frederick H, Richard A, Philip G, Runstadler JR, Weighted collagen microspunge for immobilizing bioactive materials, US Patent 4863856, 1989.
40. Embil VP, OTC external analgesic cream/topical analgesic-anti-inflammatory, counterirritant utilizing the microspunge delivery system (MDS) for controlled release of actives, UK Patent 01010586, 2000.
41. Grimee PE, Meraz M, A new microentrapped 4% hydroquinone formulation for treatment of hyperpigmentation, 60<sup>th</sup> Annual meeting of American Academy of Dermatology, 519, 2002, 22-27.