

FABRICATION OF SOLAR INVERTERS FOR HOUSEHOLD APPLICATIONS

T. Mani Mohan¹, G. Eswar Balachandar², A. Hemantha Kumar³

*^{1 & 2} Assistant Professors, Department of Mechanical Engineering, Annamacharya Institute of Technology and sciences, Rajampet, Annamayya Dist. Andhra Pradesh, India
aits.med.tmm@gmail.com, gebalachandar@gmail.com*

*³ Asst. Professor, Department of Mechanical Engineering, Annamacharya Institute of Technology and sciences, Rajampet, Annamayya Dist. Andhra Pradesh, India
ahkaits@gmail.com*

Abstract:

Solar energy has incredible potential to power our daily lives. Solar power system is one of the best renewable energy technologies which is not only cost effective but environment friendly as well. The growing interest in the use of solar energy to mitigate climate change, reduction in the cost of Photovoltaic (PV) system and other favourable factors have increased the penetration of the PV systems in the domestic market and increase in the worldwide energy supply. The main component in a distribution of AC is a smart inverter which serves as a direct interface between the Renewable Energy System (RES) and the domestic power supply or power distribution grid. This paper work presents a fabrication of inverter with power control capabilities for renewable energy sources (RES) and Distributed Generators (DG). The type of the inverter to be designed is a Voltage Source Inverter (VSI). The VSI is capable of supplying energy to the utility grid with a well-regulated DC link at its input.

1.INTRODUCTION

1.1 INTRODUCTION:

Solar power charge controller is applicable in many sectors such as solar home system, hybrid systems, solar water pump system etc. solar panel converts sun light energy into electrical energy through an electrochemical process also known as photovoltaic process. Energy stored in the battery with the help of charging circuit through a diode and a fuse. This energy will be used in case of main power failure. In the battery chemical energy is converted into electrical energy which in turn illuminates electrical appliances or helps in pumping water from the ground. Therefore, we need to protect battery from over charge, deep discharging mode while DC loads are used or in under voltage as it is the main component in a solar power charge controller. Solar panel produce direct currents (DC) to convert into AC output at a certain required voltage level and frequency connect these panels to the electricity grid. Direct currents (DC) from solar panels are converted into alternating currents (AC) at a specific voltage and frequency when they are connected to the electrical grid.

The main component of the system, the DC-AC inverter, essentially performs the conversion from DC to AC. The output of the solar panels, however, is dependent on the ambient temperature and the intensity of the sun's rays at any given moment. This work focuses on the design and construction of a solar PV-based home with an uninterrupted power supply in an

effort to continuously deliver 10 watts of electricity for a DC-powered home. In order to maintain a consistent output voltage, the solar PV is cascaded with a buck converter that has a PWM modulator circuit in its feedback. The backup power is provided by the power grid and battery. A proportional controller, which keeps the output voltage at a constant level by appropriately adjusting the buck converter's duty ratio. This buck converter's output is linked to a common DC bus.

1.2. PROPOSED SYSTEM:

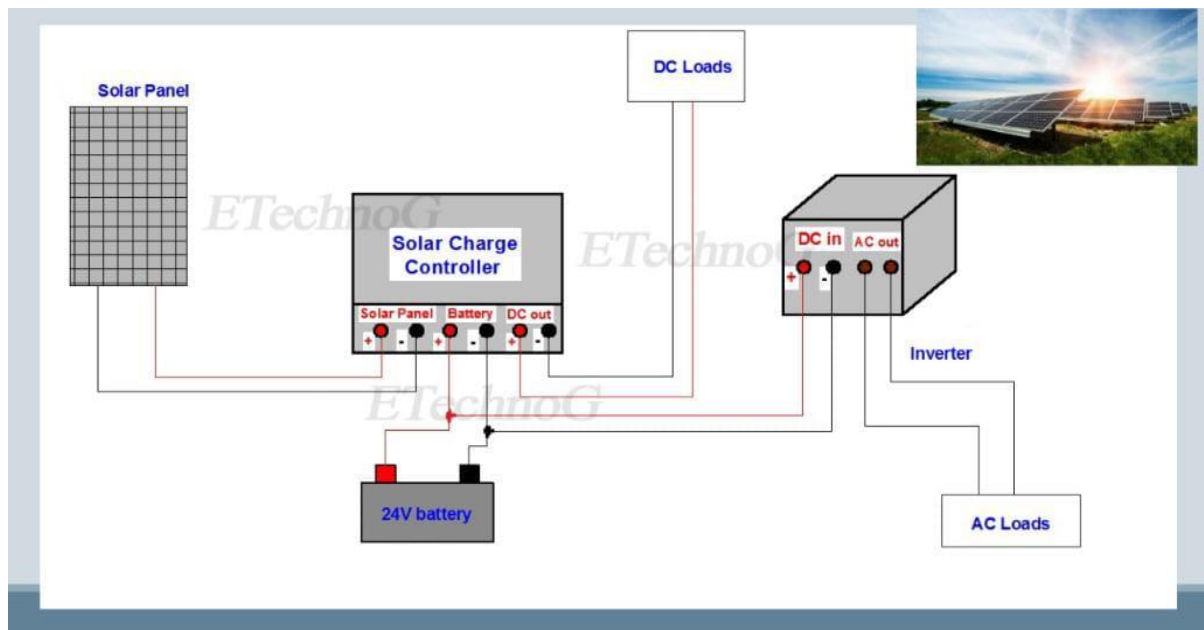

Fig.1.2(a): Proposed system

1.3. HARDWARE DESCRIPTION:

Introduction: In this chapter the block diagram of the project and design aspect of independent modules are considered. Block diagram is shown below.

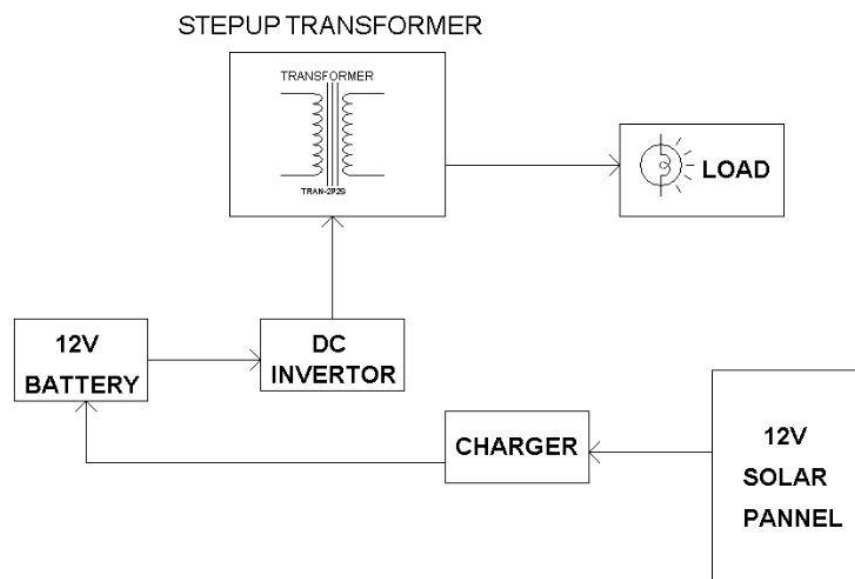

Fig.1.3.(a) : Hardware Description

Solar-powered systems went one step further by using solar energy to charge the battery, which was then used to power an AC inverter.

The 12V DC battery is constantly being charged by the solar panels with the aid of a charge controller circuit, and once the switch is turned on, the 12V battery output is fed to the inverter input. With the use of a step-up transformer, the inverter changes 12V DC into 12V AC, which is then step-up to 230V AC supply.

In this way, solar powered devices can be used during power outages or blackouts and have the capacity to serve as a primary source without the aid of an external power source. Today, grid power can be used as the primary source and solar power as a secondary source. Since the cost per unit would rise, many people will experience this issue. We can utilize grid power as a backup and solar power as a primary source to get around this issue.

1.4. HARDWARE COMPONENTS:

- 12V 20W-SOLAR PANEL
- 12V-BATTERY
- 24W – INVERTOR
- RESISTORS
- CAPACITORS
- DIODE
- WIRES
- TRANSFORMER
- LAMP BASE
- LED

1.4.1. 12V-BATTERY:

Batteries are available in a variety of forms, dimensions, and functions. One such popular battery is the 12V battery.

A common type of battery for many electrical devices and appliances is the 12-volt battery. Given that it exists in a variety of sizes and shapes, the 12-volt battery is distinctive and unique in its function.

They might occasionally be big and hefty or little and light. These might be square or cylinder-shaped batteries. Moreover, they are utilized for transportation in automobiles, boats, and other devices.

The size of a 12-volt battery is frequently impacted by its intended purpose and the amp-hour capacity. Hence, a 12 V battery signifies that a battery is supplying a voltage of 12V within the nominal load. The size of a 12-volt battery is frequently impacted by its intended purpose and the amp-hour capacity. Hence, a 12 V battery signifies that a battery is supplying a voltage of 12V within the nominal load.



Fig:1.4.1.(a) : 12V Lead – Acid Battery

We are going to use lead acid battery, because it is a sort of rechargeable battery called a lead-acid battery was initially developed in 1859 by French physicist Gaston Plante. It is the original rechargeable battery design ever made. Lead-acid batteries have a lower energy density than contemporary rechargeable batteries.

Despite this, the cells have a reasonably high power-to-weight ratio due to their capacity to produce significant surge currents.

These qualities make them appealing for use in motor vehicles to supply the high current needed by starter motors, in addition to their inexpensive price. Lead-acid batteries have a limited cycle lifespan and longevity in general.

1.4.2. 24W – INVERTOR:

The direct current (DC) from solar panels is transformed into the alternating current (AC), which is used by home and commercial appliances, via a solar inverter. It is frequently referred to as the brain of a solar system and is one of the most important parts of a solar power system since it transforms energy from the sun into more useable energy. As solar energy cannot be used to drive electrical appliances directly, solar inverters are an essential component of a solar

system. Solar inverters used to be simple devices that converted DC into AC, but they have since developed into far more intelligent devices capable of monitoring data, operating sophisticated utility controls, and other tasks.

Fig:1.4.2.(a) : 24W-Inverter

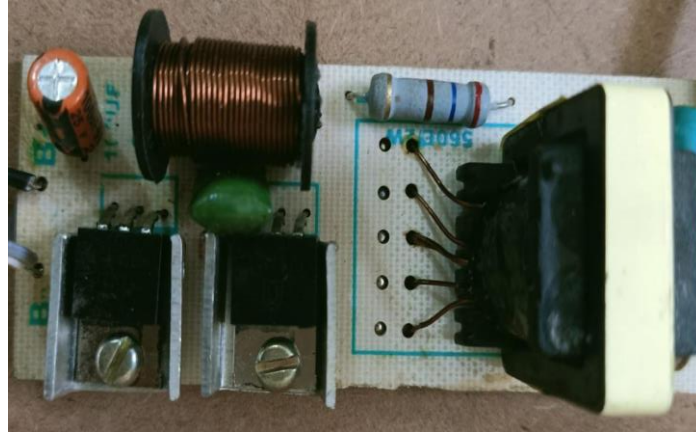

The 12V DC to 230V AC inverter circuit was created using a few components that are readily available. In locations where it is impossible to obtain an AC supply from the mains, inverters are frequently required.

The DC electricity is transformed into AC power using an inverter circuit. When using a low voltage DC supply or battery to generate high voltage, inverter circuits are quite beneficial. It is also possible to utilize a DC-DC converter circuit, however it has some voltage restrictions. Using IC CD4047, the 12V DC to 230V AC inverter circuit was created. An oscillating switching pulse device is the IC CD4047.

Switching is performed using the n-channel power MOSFET IRFZ44n. By converting low AC to high AC, the 12-0-12V secondary transformer is employed as a step-up transformer in the opposite direction.

2.PROJECT DESCRIPTION

This chapter explains the circuit diagram of a inverter system and also explains the working of CD4047.

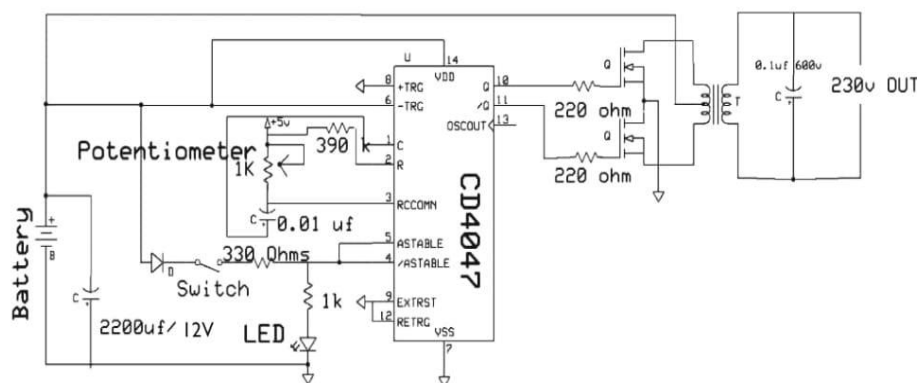

Fig:2(a) : Project Circuit System

2.1. INVERTER CIRCUIT EXPLANATION:

The central element in this circuit is the IC CD4047. The integrated circuit is configured as an astable multivibrator. This was accomplished with the assistance of a potentiometer VR1 in the circuit. By varying this potentiometer and capacitor C1, different ranges of output pulses at an IC's pins 10 and 11 can be obtained. The drain pins of Mosfets, on the other hand, are connected to the secondary of the transformer in the circuit. Furthermore, the source pins are connected to the battery's negative terminal. As a result, when the alternate pulses reach an IC's pins 10 and 11, they drive the Mosfets. As a result, it forced the secondary winding to generate alternate magnetic fields. As a result, the magnetic field generates a high voltage.

2.2. MULTI VIBRATOR IC CD4047:

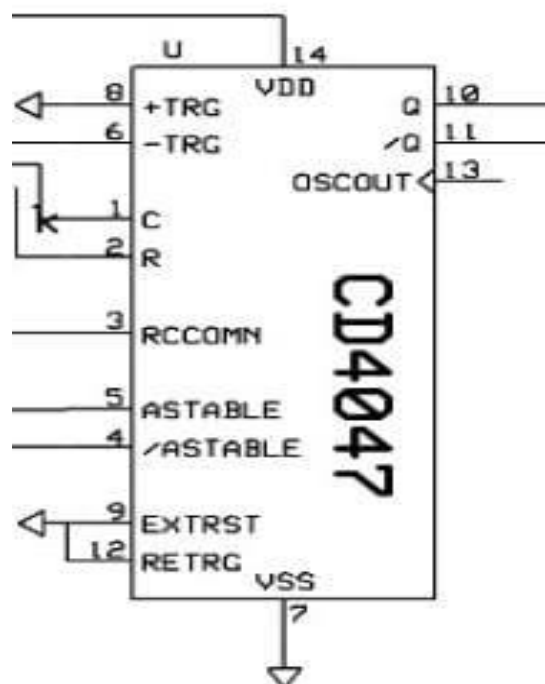

Fig:2.2(a) : CD4047

CD4047 act as a multivibrator, it consists of 14 pins which are connected in different ways.

- Pin 1(capacitor) and Pin 2(resistor) are input to the multivibrator, which is connected to the rheostat.
- Pin 3 is a RC-Common terminals, which is attached to the external resistor.
- Pin 4 is a stable input.
- Pin 5 is astable(monostable) input.
- Pin 6 is a negative triggering pulse.
- Pin 10 and Pin 11 are output signals which are connected to the transformer.
- Pin 7,8,9,12,13 are connected to ground.
- Pin 8 is a positive trigger and it is used for the signal at this input is triggered by a low to high transition, monostable operation is enabled.
- Pin 9 is a external reset and it is used to reset input is connected to the high level, the

output Q and non-inverting output are both reset to 0.

- Pin 12 is used to simultaneously trigger pins 7 and 8 in monostable mode.
- Pin 13 is a OSC output, it oscillates the output in astable mode.
- Pin 14 is a power source.

2.3. POWER SUPPLY TO BATTERY:

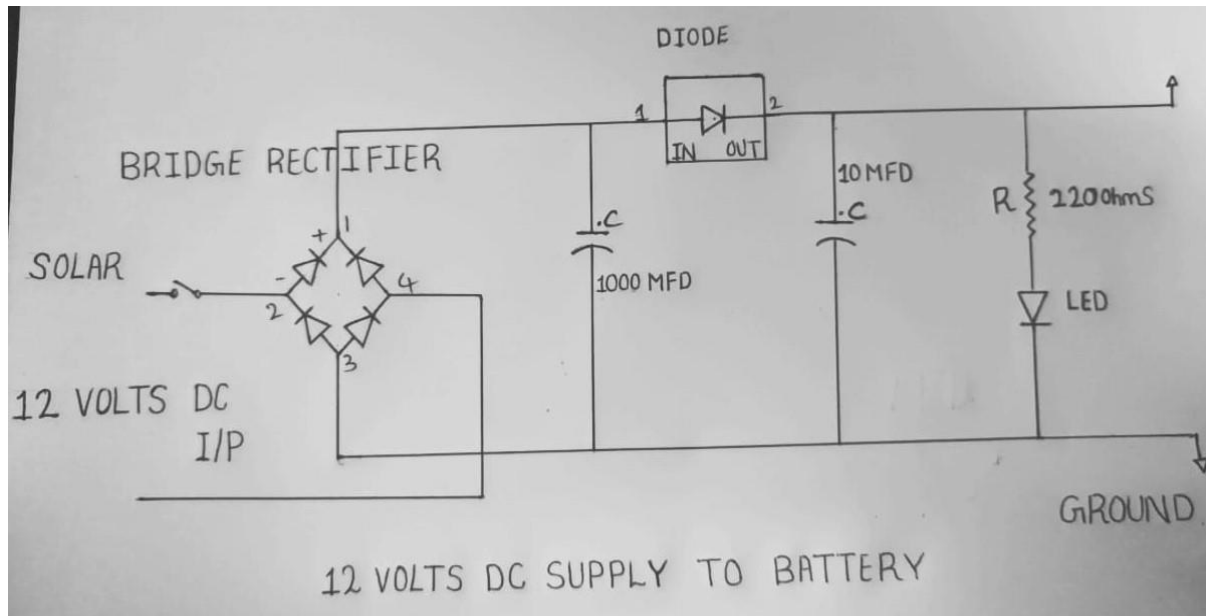

Fig.2.3(a) : Power Supply Of Battery

When we turn on the switch the power coming from the solar panel is supplied to the **DB107**, we use **DB107** as a bridge rectifier, which converts an ac voltage to dc voltage using both half cycles of the input ac voltage, then the source is connected to the capacitor which helps to supply the required power.

It is connected to the diode, which allows the power in only one direction another capacitor is connected then it is connected to the resistor to control the current flow then finally it is connected to the LED, based on the circuit connections LED will blink.

2.4 DB107:

These days The IC part number for bridge rectifiers is DB107. An IC is being used in place of a bridge rectifier in our project.

RESULTS

The project “**Fabrication of solar inverters for household applications**” was designed such that to deliver power to switch on the loads like tube light, fans and some other applications. The system uses solar energy for rural electrification. In this project solar energy is treated as non-renewable source of energy. The system also uses switch to control the devices.

CONCLUSION:

The cost of electrification associated with houses in rural areas that increases with distance between the grid and the houses. Such instances where the cost of electrification becomes enormous, one can always use an off-grid photovoltaic (PV) system.

The comprehensive overview of power electronics inverter was studied at the beginning of this thesis. The complete design and fabrication of inverter for the single-phase grid connected was presented in this thesis. Through designing and fabrication of the inverter, this thesis was able to achieve its objectives in part load and peak load demands.

REFERENCE

1. INSODE 2011 Solar powered UPS Haris Jawaida , Nadeem Ehsanb*, EbtisamMirzac , Muhammad Waseem Bhatti V.Rattankumar, AssistantProfessor(GrII), AVIT,Chennai, rattan.eee@gmail.com, P.Poornima , Assistant Professor (Gr-II), AVIT, Chennai –“Study Of Solar Ups For Design, Illustrate & Commissioning Of Smart Inverter Based Ups”.
2. Bandla Pavan Babu, P.Venkatesh, T.Swetha, D.ViswaTeja,Sk .Masoor Assistant Professor -“Solar powered ups”.
3. 4.Yongheng Yang, Student Member, IEEE, Huai Wang, Member, IEEE, FredeBlaabjerg, Fellow, IEEE and Tamas Kerekes, Member, IEEE – “A Hybrid Power Control Concept for PV Inverters with Reduced Thermal Loading”.
4. Ariya Sangwongwanich, Student Member, IEEE, Yongheng Yang, Member, IEEE, FredeBlaabjerg, Fellow, IEEE, and Dezso Sera, Senior Member, IEEE - “Delta Power Control Strategy for Multistring Grid-Connected PV Inverters”.
5. 6.Radha Mahajan, Harshada Lonkar, Prachi Ghormade, Rajvi Kuthe – “Implementation of Solar Inverter using Microcontroller”.
6. Sachin Jain and Vivek Agarwal, Senior Member, IEEE – “A Single-Stage Grid Connected Inverter Topology for Solar PV Systems With Maximum Power Point Tracking”.
7. 8.Simon Rohlén Martin Skilbred–“Strategy for designing solar powered UPS systems”.
8. Haris Jawaida , Nadeem Ehsanb*, EbtisamMirzac , Muhammad Waseem Bhattid – “Study of Solar powered UPS”.
9. 10.Recent trends in solar PV inverter topologies Author links open overlay panel Raveendhra Dogga, M.K. Pathak.
10. 11.Alexander S, Albert, 2016. "Development of solar photovoltaic inverter with reduced harmonic distortions suitable for Indian sub-continent," Renewable and Sustainable Energy Reviews, Elsevier, vol. 56(C), pages 694-704.
11. 12.Analysis and Design of Solar Photo voltaic Grid Connected Inverter - *Muddasani Satyanarayana, P. Satish Kumar.*