

HUMAN CARRYING QUADCOPTER

¹P. Karunakar,²D. Venkata Ramana,³K. Madhu

^{1,2,3}Assistant Professor

Department Of Mechanical Engineering

Christu Jyothi Institute Of Technology & Science, Colombo Nagar, Telangana

ABSTRACT :

Unmanned Aerial Vehicles (UAVs) like drones and quadcopters have revolutionized flight. They help humans to take to the air in new, profound ways. The military use of larger size UAVs has grown because of their ability to operate in dangerous locations while keeping their human operators at a safe distance. Here quadcopter as a small UAV is discussed. It is the unmanned air vehicles and playing a predominant role in different areas like surveillance, military operations, fire sensing, traffic control and commercial and industrial applications. We found that the debate is characterized by predominantly technical and regulatory problems and barriers which are considered to prevent or impede the use of drones for parcel and passengers' transportation.

Keywords: *Quad rotor helicopter or Quad rotor, drone's, vertically oriented propellers*

INTRODUCTION

A Quad copter, also called a Quad rotor helicopter or Quad rotor, is a multi- rotor helicopter that is lifted and propelled by four rotors. Quad copters are classified as rotorcraft, as opposed to fixed-wing aircraft, because their lift is generated by a set of rotors (vertically oriented propellers). Unlike most helicopters, quad copters use two sets of identical fixed pitched propellers; two clockwise (CW) and two counter- clockwise (CCW). These use variation of RPM to control lift and torque. Control of vehicle motion is achieved by altering the rotation rate of one or more rotor discs, thereby changing its torque load and thrust/lift characteristics. Target and decoy – providing ground and aerial gunnery a target that simulates an enemy aircraft or missile

1.1 Scope of Project :

The purpose of this project is to engineering knowledge to develop a UAV at low cost based on specifications as finalized in SOR. project will engage the members through proper design cycle which will include the implementation of the aircraft design knowledge, as well as other courses, use of the various CAD software that they have learnt for design and analysis of their project and make critical decisions regarding their design observing its performance as well as their constraints such as budget, manufacturability Etc.



Figure 1: Quadcopter during transition

LITERATURE SURVEY

In this section the literature survey of weight carrying quadcopters is discussed. The experimentations conducted by various researchers by influencing the unmanned aerial vehicles (UAV) process parameters on specific weight carrying method's.

2.1 Quadcopter history :

Etienne Oehmichen was the first scientist who experimented with rotorcraft designs in the 1920s. Among the six designs he tried, his second multicopper had four rotors and eight propellers, all driven by a single engine. The Oehmichen used a steel-tube frame, with two-bladed rotors at the ends of the four arms. The angle of these blades could be varied by warping. Five of the propellers, spinning in the horizontal plane, stabilized the machine laterally. Another propeller was mounted at the nose for steering. The remaining pair of propellers was for forward propulsion.

METHODOLOGY

In a quadcopter drone, two of the motors rotate in a clockwise direction and the other two motors in an anticlockwise direction. The speed of the motors is controlled by the electronic speed controller. If the two motors on the rear side of the drone rotate at high speeds, then the drone moves in a forward direction. If the two motors on the front side of the drone rotate at high speeds, then the drone moves in a backward direction. If the two motors on the left side of the drone rotate at high speeds, then the drone moves in a rightward direction.

Introduction with System Block Diagram :

A block diagram is a high-level and specialized flowchart used in engineering. It is used to describe and improve existing systems or to design new

ones. The block diagram's structure provides a high-level overview of important working relationships, key process participants, and major system components. Below is the overview of the major quadcopter components represented as a block diagram

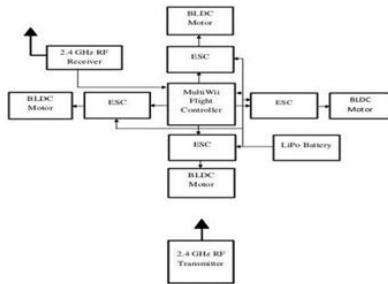

Figure 2: Block diagram of a Quadcopter Technical Specification:

The drone's technical specification is nothing more than a document that through technical data makes a clarified description for the drone's specific use, functionality, or performance



Figure 3: Block diagram of a drone's specific use, functionality

Designing of Quadcopter body:

A quadcopter is a multi-rotor drone that has four arms having a brushless dc motor on each arm. Quadcopter drone arms are designed in fusion 360 software. Hence this is a delivery drone, the middle part of the body has to be strong to carry the loads. so, a sheet metal body has to be used for the upper and bottom parts of the drone connecting four arms. The drone planned for the current work is initially modeled in fusion 360 software. Figure 2 shows the design frame of the drone in fusion 360 software.



Figure 4 Modeling and rendering of a Quadcopter Drone in fusion 360

Fabrication:

3D printing is also known as additive manufacturing, and it is the process of building a

3d object from a CAD model. The arms of quadcopter drone designed in fusion 360 software, Additive manufacturing of quadcopter arms by using PLA (Polylactic Acid) Filament in 3D printing. Repetier Host software is used for slicing and Creaity Ender 3.0 is used for printing parts.

Parameter	Value
Shell Thickness	2 mm
Top and Bottom Thickness	2 mm
Infill Pattern	Grid
Support Pattern	Grid
Fill Amount	15%
Print Speed	25 mm/s
Travel Speed	60 mm/s
Layer Thickness	0.2 mm

Table : 1 Printing parameters

Assembly and Flight Testing:

3D printed arms of quadcopter assembled to the sheet metal body of the drone. Figure shows the fabrication of the sheet metal body. A Brushless DC motor is connected to the electronic speed controller(ESC). Motors are placed on edge of the arms and ESC is placed in the middle of the arms. A power distribution board is used to distribute the power to all components. APM flight controller is placed in the middle of the drone and it's connected to the receiver, ESC, GPS module, and power module.



Figure: 5 Final Assessment of the Robot

Hardware components: Most of the parts on a quadcopter are dependant on each other and when choosing one part it puts a new set of demands on another. The one most important characteristic to out is the weight if the Quadcopter, since that in turn puts demand on all parts except the ones handling calculations for navigation.

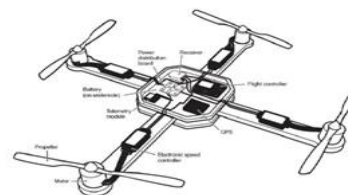

Figure : 6 Overall structure of the Drone

1.Motor: The motors together with the propellers are needed to provide enough thrust to lift the Quadcopter with the gripping module and a payload of up to 20% of the total weight. Since the aim is to follow a 2:1 thrust to weight ratio, the total minimum thrust needed to be at least 1.5 kg.

PROPELLORS:

A propeller is a type of fan that transmits power by converting rotational motion into thrust. A pressure difference is produced between the forward and rear surfaces of the airfoil-shaped blade, and a fluid (such as air or water) is accelerated behind the blade. Propeller dynamics can be modelled by both Bernoulli's principle and Newton's third law.

It is also the main part of the quad copter for flying, there are two types of propellers used in the quad copter they mostly left-hand propellers and right-hand propellers. 25 Left hand propellers are also called normal propellers and they are mounted to the motor which is moving in counterclockwise direction.

MULTI ROTOR CONTROL BOARD

The KK.2 multi controller is a flight control board for remote control multi copters with 2,3,4 and 6 rotors. Its purpose is to stabilise the aircraft during flight. To do this it takes the signal from the three gyros on the board (roll, pitch and yaw) and feeds the information into the Integrated Circuit (Atmega IC). This then processes the information according to the KK software and sends out a control signal to the Electronic Speed Controllers (ESCs) which are plugged onto the board and also connected to the motors.

Specifications: -

Size: 50.5mm x 50.5mm x 12mm Weight: 21 gram (IncPiezo buzzer)IC: Atmega324 PA

Gyro: InvenSense Inc.

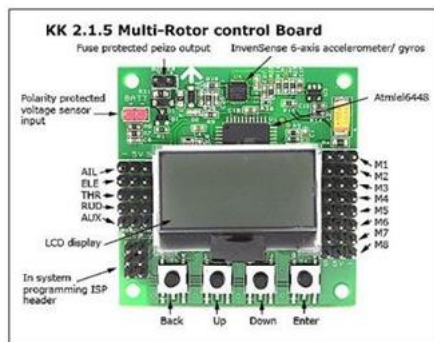

Figure:7 Multi-rotor control board

ELECTRONIC SPEED CONTROLLER(ESC

An electronic speed control or ESC is an electronic circuit with the purpose to vary an electric motor's speed, its direction and possibly also to act as a dynamic brake. ESCs are often used on electrically powered radio controlled models, with the variety most often used for brushless motors essentially providing an electronically generated three-phase electric power low voltage source of energy for the

motor.

We have used 60A electronic speed controllers to control each brushless motors in this experiment which can constantly supply required current to drive brushless motors. It has following specifications:

Constant Current: 60A

Burst Current: 80A

BRUSHLESS MOTOR

Brushless DC electric motor (BLDC motors, BL motors) also known as electronically commutated motors (ECMs, EC motors) are synchronous motors which are powered by a DC electric source via an integrated inverter/switching power supply, which produces an AC electric signal to drive the motor (AC, alternating current, does not imply a sinusoidal waveform but rather a bi-directional current with no restriction on waveform); additional sensors and electronics control the inverter output amplitude and waveform and frequency (i.e. rotor speed).

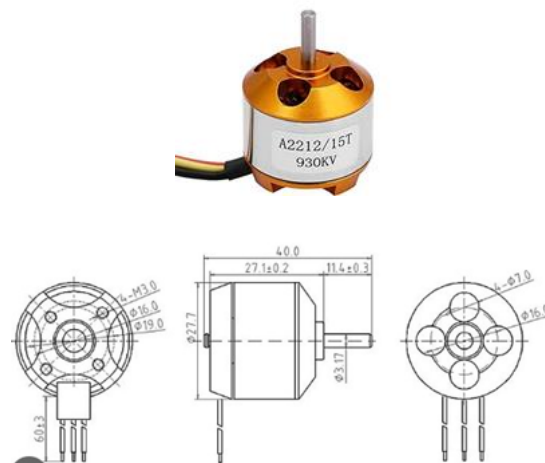

FIGURE: 8 Brushless Motor

LITHIUM POLYMER (LI-PO) BATTERY

LiPo batteries (short for Lithium Polymer) are a type of rechargeable battery that have become very popular because of their power to rate ratio. In other words, more electricity in a lighter package. Obviously, this is ideal for anything you're trying to get to fly. Another advantage is that LiPo's have a high discharge rate – which means they can deliver large amounts of power at once.



FIGUER: 9 Li-Po Battery

Specifications:

- Battery Configuration: 11.1V 2200mAh 3cell
- Battery Capacity: 2200mAh
- Max Continuous Discharge (C-rate/current): 20C Max Burst (3Sec) (C-rate/current): 45C

An RF Module (Radio Frequency Module) is a usually small electronic circuit used to transmit and/or receive radio signals on one of a number of carrier frequencies. RF Modules are widely used in electronic design owing to the difficulty of designing radio circuitry.



Figure: 10 Frequency transmitter

Receiver specification :

- Channel: 6
- Frequency band: 2.4GHz
- Power resource: 1.5V*4''AA''battery
- Program type: GFSK
- Weight: 25G

Schematic of reaction torques on each motor of a quadcopter aircraft, due to spinning rotors. Rotors 1 and 3 spin in one direction, while rotors 2 and 4 spin in the opposite direction, yielding opposing torques for control.

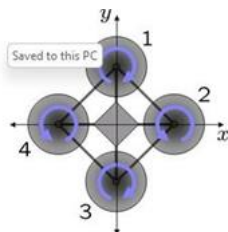

Figure: 11 Spinning direction



Working principle and working

In this study, the aircraft was assumed to be a drone, which means it also stores the energy in the battery during the flying period. In this way, both flying the drone by using solar energy and storing the energy in the battery in order to extend the flight time can be achieved. The principle in which the drone works on it is NEWTONS

THIRD LAW OF MOTION.



Figure:12 Pitch motion

RESULTS

The testing done includes both the testing with different Payload, the testing of the Quadcopter. So in order for the testing to go on many things have to be done which includes

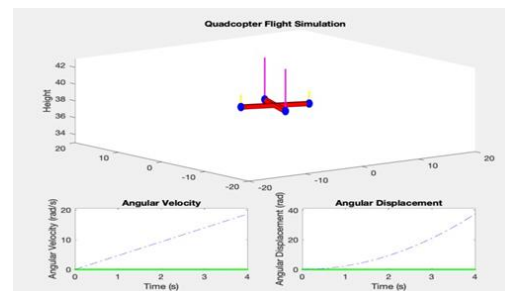

Figure:13 testing with different Payload Application Performance Management (APM) has

to stabilize and when this is done you hear the peep sound telling you that the Quadcopter is ready.

After that the APM is armed.

The throttle is increased slightly.

Then on the transmitter it should be in channel 1

After it is switched to channel 2 which autonomously fly.

After that the return to launch mode helps it return to origin

CONCLUSION

The process of module transportation, rigging, lifting, and installation is unique to the modular construction method, one of the critical barriers to implementing the modular construction technique and executed inefficiently by practitioners. If the process is innovated, the construction industry will achieve broader and more effective use of modularization. Recently, drones have drawn increasing attention from researchers and others in the construction industry due to rapid advancements in related technologies and applications.

The key challenges that have been identified from the manual test flight are:

Limited payload.

Limited power supply.

Dynamic properties of a module.

Agility/instability of uas; and

Regulations.

However, if these challenges can be overcome through the use of the UAV-based module method, transportation times, lifting times, and costs can be significantly reduced, eventually diminishing total installation costs, and expediting the overall construction process. This innovative method will help the industry to overcome key barriers of modular construction: site access problems, site congestion issues, and the limited availability of local heavy lift equipment.

REFERENCES

CFD study of an annular-ducted fan lift system for VTOL aircraft 2015 by Yun Jiang, Bo Zhang & Tao Huang

https://www.researchgate.net/publication/282350303_CFD_study_of_an_annul

Quadcopter thrust optimization with ducted-propeller 2017 by Endorsees Kuantama & RaduCatalin Tarca

https://www.researchgate.net/publication/32028519_9_Quadcopter_thrust_optimization_with_ducted-

propeller

How ducting a propeller increases efficiency and thrust

<https://www.youtube.com/watch?v=Cew5JF8q6eY>

Standardization December 2018roadmapFor Unmanned Aircraft Systems, Version 1.0 Prepared by the ANSI Unmanned Aircraft Systems Standardization Collaborative (UASSC)

Brushless DC Motor vs. AC Motor vs. Brushed Motor in oriental motor. <https://www.orientalmotor.com/brushless-dc-motors-gear-motors/technology/AC-brushless-brushed-motors.html>

Brushless Motors vs. Brushed Motors - What's the Difference

<https://www.thomasnet.com/articles/machinery-tools-supplies/brushless-motors-vs-brushedmotors/>

https://www.amazon.com/RSII2206-Brushless-Support-Compatible-Quadcopter/product?reviews/B07HJ3C5TR?reviewerType=all_reviews

erType=all_reviews

All About a Multicopter FPV

Drone Power Distribution Board |

Getup Learn <https://www.getfpv.com/learn/new-to-fpv/all-about-multicopter-fpv-drone-power-distributionboard/>

[https://dronenodes.com/drone-flight-controller-fpv/](https://dronenodes.com/drone-flight-controller-fpv/Drone%20Transmitter%20and%20Receiver%20-%20Radio%20Control%20System%20Guide%20-%20Drone%20Nodes)

Drone Transmitter and Receiver – Radio Control System Guide - Drone Nodes