

## **IOT BASED THEFT DETECTION USING RASPBERRY PI**

*<sup>1</sup>P Thirupathi, <sup>2</sup>D Rita Faria, <sup>3</sup>S Swathi, <sup>4</sup>Thasleem*

*<sup>1,2,3</sup>Assistant Professor, <sup>4</sup>Student*

*Department Of ECE*

*Christu Jyothi Institute Of Technology & Science, Colombo Nagar, Telangana*

### **ABSTRACT**

In the present day, Security and Safety are the major concern for the personage. We use C-Mount monitors in order to monitor and identify, but the C-mount has too much ability to record and needs staff to monitor the unlawful movement. Mobile device like Smart phones and I pad are used to perform daily tasks that are handle by commercial computers and laptop. Be overcome, we have found RP-3 model using IOT RP-3 model is much lowered compared to existing system with more appropriate settlement and less power use characteristics an "Internet Of Thing based Theft Detection using Raspberry Pi" Project where we had to use live video photo processing to espy stealer using motion as well as focus the area where motion reoccurred. In this model, we usea NRP-camera together RP-3 model together with a route with Virtual show infrared for night andThumb drive for Data Storage. The model uses imaging to espy and emphasize the exact filed of movement in the camera when camera movement is espying.

### **I. INTRODUCTION**

In our more technologically aware society, theft prevention would be a godsend. Many theft detection systems are available to catch the thief, and they can be improved even more. In some cases, the thief cannot be apprehended using this technology. Even if the thief is apprehended, the victim will lose access to his or her valuables. "It is better to prevent than to cure." The person will not suffer any harm if the theft is avoided. The goal of the research is to evaluate an operating system's performance on an embedded system. Before diving into the implementation, a brief overview of the project's components is required. "IoT-based theft detection project utilizing Raspberry Pi" is what we suggest here. With cloud services dominating the ever-increasing electronics product market, the Internet of Things (IoT) has ruled the electronics era. This technology protects offices and residences against theft by detecting theft instantaneously and allows the user to examine the details of the theft, highlighting the details and recording the video to a USB drive. We use a camera, a Raspberry Pi, and a circuit with an LCD display with infrared for night vision and a USB drive for storage in this system. A 12V power supply is used to run the system. When camera motion is detected in the video, the system employs image processing to pinpoint the precise location of the motion and highlights it. The technology now sends photographs of the occurrence to the user's computer via IoT, where they may be seen online. The online system is built with IoT Gecko here. It also saves the video to a USB device for later use. The user can now use the IoT Gecko IoT system to decode the data supplied online and examine the images of the motion event live over the internet. As a result, the system uses IoT to deliver a novel method for theft detection.

### **II. LITERATURE SURVEY**

1.D. Pavithra; Ranjith Balakrishnan, "IOT based

monitoring and control system for home automation

The project proposes an efficient implementation for IOT (Internet of Things) used for monitoring and controlling the home appliances via World Wide Web. Home automation system uses the portable devices as a user interface. They can communicate with home automation network through an Internet gateway, by means of low power communication protocols like Zigbee, Wi-Fi etc. This project aims at controlling home appliances via Smartphone using Wi-Fi as communication protocol and raspberry pi as server system. he user here will move directly with the system through a web-based interface over the web, whereas home appliances like lights, fan and door lock are remotely controlled through easy website. An extra feature that enhances the facet of protection from fireplace accidents is its capability of sleuthing the smoke in order that within the event of any fireplace, associates an alerting message and an image is sent to Smartphone. The server will be interfaced with relay hardware circuits that control the appliances running at home. The communication with server allows the user to select the appropriate device. The communication with server permits the user to pick out the acceptable device. The server communicates with the corresponding relays. If the web affiliation is down or the server isn't up, the embedded system board still will manage and operate the appliances domestically. By this we provide a climbable and price effective Home Automation system.

Sadhana Godbole, Shivani Deshpande, Neha Barve, Sakshi Galim –NBNSOIE, "Review on Theft Prevention System using Raspberry Pi and PIR Sensor"

In this proposed system, theft can be prevented using Raspberry pi and PIR sensors. In this system PIR sensors, camera, buzzer, relay, GSM module are connected to Raspberry pi. PIR sensors are able to detect the presence of human being. After detecting any person, relays are triggered to switch on the lights. As soon as lights are on,

buzzer will start ringing for specified time. After lights are turned on an image will be captured using cameras. This captured image will immediately upload on the webpage, which can be used as evidence. In addition, victim receives a notification in the form of text message with help of GSM module. Power supply to this system is given by an adapter. In absence of electricity battery backup is also provided. As the lights turn on and the buzzer rings, neighborhood becomes aware about a theft. This will make the thief scared and thief would try to escape the location. Thief is not able to execute his/her plan, belongings will be safe. This system can be implemented in jewellery shops, home etc.

**III. BLOCK DIAGRAM OF PROJECT AND FUNCTIONING:  
BLOCK DIAGRAM:**

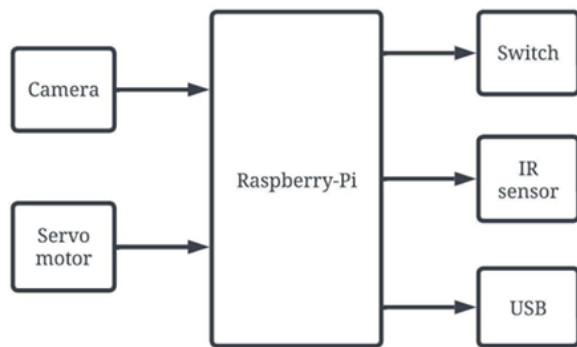

Fig.:1 block Diagram of Iot based theft detection using raspberry-pi

**IV. HARDWARE:**

**RASPBERRY PI**

Raspberry Pi (/paɪ/) is a series of small single-board computers (SBCs) developed in the United Kingdom by the Raspberry Pi Foundation in association with Broadcom.<sup>[14]</sup> The Raspberry Pi project originally leaned towards the promotion of teaching basic computer science in schools.<sup>[15][16][17]</sup> The original model became more popular than anticipated,<sup>[18]</sup> selling outside its target market for uses such as robotics. It is widely used in many areas, such as for weather monitoring,<sup>[19]</sup> because of its low cost, modularity, and open design. It is typically used by computer and electronic hobbyists, due to its adoption of the HDMI and USB standards.

After the release of the second board type, the Raspberry Pi Foundation set up a new entity, named Raspberry Pi Trading, and installed Eben Upton as CEO, with the responsibility of developing technology.<sup>[20]</sup> The Foundation was rededicated as an educational charity for promoting the teaching of basic computer science in schools and developing countries. Most Pis are made in a Sony factory in Pencoed, Wales,<sup>[21]</sup> while others are made

in China and Japan.<sup>[22][23]</sup>



Fig 2. Raspberry Pi

Raspberry Pi 3 board contains BCM2837 controller which supports ARM11 processing unit. This is the Broadcom chip used in the Raspberry Pi 3, and in later models of the Raspberry Pi 2. The underlying architecture of the BCM2837 is identical to the BCM2836. The only significant difference is the replacement of the ARMv7 quad core cluster with a quad-core ARM Cortex A53 (ARMv8) cluster.

The ARM cores run at 1.2GHz, making the device about 50% faster than the Raspberry Pi 2.

The VideocoreIV runs at 400Mhz.

**POWER SUPPLY**

The input to the circuit is applied from the regulated power supply. The a.c. input i.e., 230V from the mains supply is step down by the transformer to 12V and is fed to a rectifier. The output obtained from the rectifier is a pulsating d.c voltage. So in order to get a pure d.c voltage, the output voltage from the rectifier is fed to a filter to remove any a.c components present even after rectification. Now, this voltage is given to a voltage regulator to obtain a pure constant dc voltage.

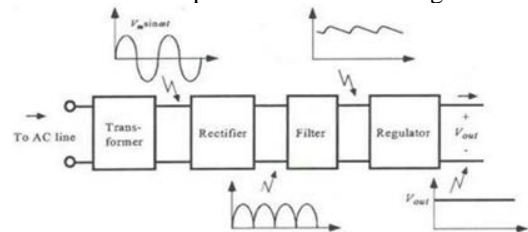

Fig:3 Block Diagram of Power supply

**INTRODUCTION TO CAMERA**

Camera plays a vital role in automation purpose. The camera is used for monitoring of a room from a remote place. The camera used is a USB camera (life cam vx-800). Whenever the user clicks on to video button on loaded webpage, the corresponding room video will be streamed on to webpage. For this purpose, we use a MJPG streamer. The below figure shows the camera that has been used for monitoring of a room.



Fig:4 Camera

### DISPLAY

Display Is A Computer Output Surface And Projecting Mechanism That Shows Text And Often Graphic Images To The Computer User, Using A Cathode Ray Tube ( CRT ), Liquid Crystal Display ( LCD ), Light-Emitting Diode, Gas Plasma, Or Other Image Projection Technology. The Display Is Usually Considered to Include The Screen Or Projection Surface and The Device That Produces the Information on The Screen. In Some Computers, The Display Is Packaged in A Separate Unit Called A Monitor . In Other Computers, The Display Is Integrated into A Unit with The Processor and Other Parts of The Computer. (Some Sources Make the Distinction That the Monitor Includes Other Signal-Handling Devices That Feed and Control the Display or Projection Device. However, This Distinction Disappears When All These Parts Become Integrated into A Total Unit, As in The Case of Notebook Computers.) Displays (And Monitors) Are Also Sometimes Called *Video Display Terminals (Vdts)*. The Terms *Display* and *Monitor* Are Often Used Interchangeably.

### SERVO MOTOR

A servo motor is a type of motor that can rotate with great precision. Normally this type of motor consists of a control circuit that provides feedback on the current position of the motor shaft, this feedback allows the servo motors to rotate with great precision. If you want to rotate an object at some specific angles or distance, then you use a servo motor. It is just made up of a simple motor which runs through a servo mechanism. If motor is powered by a DC power supply, then it is called DC servo motor, and if it is AC-powered motor then it is called AC servo motor. For this tutorial, we will be discussing only about the DC servo motor working. Apart from these major classifications, there are many other types of servo motors based on the type of gear arrangement and operating characteristics. A servo motor usually comes with a gear arrangement that allows us to get a very high torque servo motor in small and lightweight packages. Due to these features, they are being used in many applications like toy car, RC helicopters and planes, Robotics, etc.



Fig:5.Servo Motor

### SWITCH

A switch is an electrical component that can disconnect or connect the conducting path in an electrical circuit, interrupting the electric current or diverting it from one conductor to another.[1][2] The most common type of switch is an electromechanical device consisting of one or more sets of movable electrical contacts connected to external circuits. When a pair of contacts is touching current can pass between them, while when the contacts are separated no current can flow.

Switches are made in many different configurations; they may have multiple sets of contacts controlled by the same knob or actuator, and the contacts may operate simultaneously, sequentially, or alternately. A switch may be operated manually, for example, a light switch or a keyboard button, or may function as a sensing element to sense the position of a machine part, liquid level, pressure, or temperature, such as a thermostat. Many specialized forms exist, such as the toggle switch, rotary switch, mercury switch, push-button switch, reversing switch, relay, and circuit breaker. A common use is control of lighting, where multiple switches may be wired into one circuit to allow convenient control of light fixtures. Switches in high-powered circuits must have special construction to prevent destructive arcing when they are opened.

### V. RESULT

#### WITHOUT POWER SUPPLY

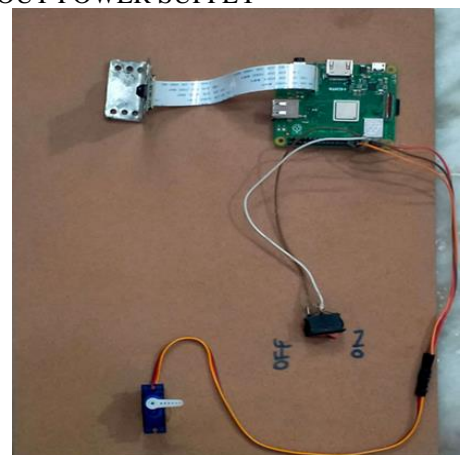

Fig:6.Without Power supply

WITH POWER SUPPLY

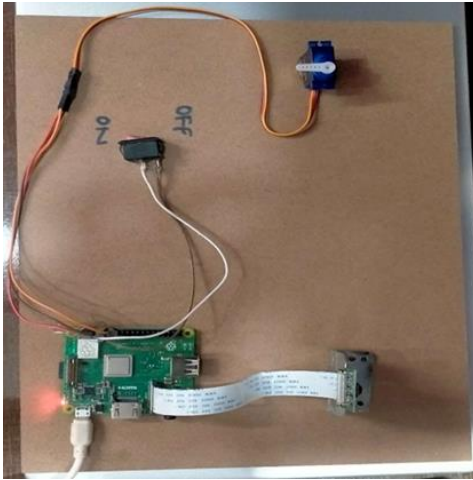

Fig:7. With Power supply

## VI. CONCLUSION & FUTURE SCOPE

### CONCLUSION

The project "IoT Based Theft Detection Using Raspberry PI" showed how to construct a completely functional embedded solution from the ground up. This includes cross-compiling and deploying key libraries, as well as setting up embedded Linux and cloud computing. This system is ideal for surveillance of tiny personal areas, such as a personal office cabin, a bank locker room, or a parking entrance. Whenever movement is detected. The project's key benefit is that it is simple to implement and has a low cost while maintaining a high level of quality.

### FUTURE SCOPE

The report's final part describes several enhancements that could be included in future editions. The existing set of features is the absolute minimum that a customer would anticipate. We will be able to save photos in the future using databases, and we will be able to boost processing speed using modern boards.

### REFERENCES

Harsha H Prasad International Research Journal of Engineering and Technology (IRJET) e- ISSN: 2395-0056 p-ISSN: 2395-0072 Volume: 06 Issue: 05 | May 2019 www.irjet.net.

Jaspreet Singh Computer Science and Engineering International Conference on Advances in computing, communication control and networking (ICACCCN2018).

Prof.K.T. Jadhao, Assistant Professor, Alamuri Ratnamala Institute of Engineering and Technology (ARIET), Thane, - Maharashtra, India ktjadhao@gmail.com.

R. Manjunathal International Research Journal of Engineering and Technology (IRJET) e- ISSN: 2395 - 0056 p-ISSN: 2395-0072 Volume: 04 Issue: 03 | Mar - 2017 www.irjet.net.

Prayag Bhatia, Shakti Rajput ,Shashank Pathak, Shivam Prasad , §School of Computing Sciences and

Engineering, VIT Chennai, Tamilnadu, India 600127  
Riddhi Patel, shruti B yagnik,'(IJCTT)-vol.5, no.4, ISSN2231- 2803, November 2013

L.Atzori ,A.lera ,G.Morabito ,”The internet of things. A survey “, Computer Network. vol.54, no.15,ISSN-2787-2805,2010.

Rajat Bhise, Nikilesh Phadnis, Rahul Bari, Vijay Dhage Iot Based Door Lock and Unlock System Using Face Recognition,” International Research Journal of Engineering and Technology (IRJET) e-ISSN: 2395-0056 Volume: 05 Issue: 12 | Dec 2018

P. Viola and M. J. Jones, Robust real-time face detection, International Journal of Computer Vision, 57 (2004), pp.137–154.

Demirel, Hasan & Anbarjafari, Gholamreza. (2009). Histogram based face recognition system. ELECTRONICS WORLD. 115. 32-37.

Z. Cha, and Z. Zhang. "A survey of recent advances in face detection " ,Learning, no. June, p. 17, 2010

Hongming Zhang and Debin Zhao from Department of Computer Science and Engineering, Harbin Institute of Technology, Harbin, 150001, China.