

ARDUINO-BASED DIGITAL DOOR LOCK SYSTEM WITH BLUETOOTH CONNECTIVITY

¹Boini Sireesha, ²Balem Sindhuja, ³Kama Bhargavi, ⁴Banoth Rakesh

^{1,2,3}Assistant Professor, ⁴Student

Department of ECE

Abdul Kalam Institute of Technological Sciences, Kothagudem, Telangana

ABSTRACT

Providing security is the project's main goal. These days, every company needs a security system. One technology that is utilised for security in many organisations is the access control system. This project's primary goal is to restrict access to authorised users alone and grant it only in the event that a given user's password matches. For security reasons, these doors with secret code locking mechanisms are very helpful. Numerous departments, including the Department of Defence, military zones, Research and Development, bank security, and protection for critical documents This kind can be used by industries, godowns, etc. when a high degree of security is required. The primary benefit of this method, which is applicable even domestically, is that only individuals with permission can open these doors. This system is intelligent enough to only accept legitimate passwords. The operator is presented with a four-digit code as a password; if the code is typed correctly using the Bluetooth keyboard, the door will open immediately. A message is sent over Bluetooth to the authorised mobile device and a buzzer is sounded if the password is entered incorrectly. It also features a mechanism with push buttons that allows the user to input the right pattern. If the password is entered correctly, the door will open; if not, a message will be sent to the device that is within range of the Bluetooth module (HC05), and the buzzer will sound.

I.INTRODUCTION

1.1 INTRODUCTION TO THE PROJECT:

The aim of this project is to provide the security. Now a days security system is must for every organization. Access control system is one system that is used for security purpose in many organizations. The main aim of this project is to provide access only if the password of particular user is matched. So, that access is denied to unauthorized persons.

These kinds of doors with secret code locking systems are quite useful for the security purposes. Many departments like Defense, military areas, Research centers, bank security and security for important documents Industries, go-downs, etc, can adopt this type where high level security is essential. The same system can be used even at domestic side also; the main

advantage of this system is that only authorized persons can operate this door.

This system has intelligence of allowing only valid password. A password in the form of four digits code is offered to the operator, if the correct code is entered through the keyboard of the Bluetooth, then the door will be opened automatically. If the password is wrong, then a message is sent to the authorized mobile through the Bluetooth and, buzzer will be activated

This system also has intelligence of allowing valid password through physical keypad. A password in the form of four digits code is offered to the operator, if the correct code is entered through the keyboard (4 keys), then the door will be opened automatically. If the password is wrong, buzzer will be activated

Both physical and Bluetooth verification is provided in order to provide accessibility to the user, all the users have to install particular software if only Bluetooth facility is available. So, in order to surpass this obstacle, we are using physical keypad

II.LITERATURE SURVEY:

The literature review focuses on related projects authored by other researchers, the challenges they encountered, limits, and changes that should be implemented. It provides you with more access to communicate with the door, and it also gives access to physically disabled people entry that may not have a finger to use for a biometric lock or may be unable to use RFID, but with regard, this project allows differently abled people to unlock their doors with a single click on a smartphone.

Adarsh v Patil in [2008] completed a same project, android-based smart door Locking system, which also used an Android phone, that is also a smart phone, and a GSM module to open the door.

Shafarana A.R.F et al (2017) created an android-powered automation and security system for smart houses. Umar Muhammad el al (2020) created a similar project based on 'smart door security system using Arduino and Bluetooth'. Many additional 5 projects on smart door have been completed in other countries. They are all distinct in terms of design, features, devices, and algorithms. They are generally intended to meet specific purposes and to make use of components that are readily available in the relevant places. Some are inexpensive, while others are quite costly. Working requires the availability of both gear and software. After a lengthy search, I discovered a huge number of articles. While looking for publications on security, I came across some projects for door security. Many Arduino or Raspberry Pi projects are solely for security purposes. Again, the ideas are limited to using Arduino or Raspberry Pi to control home appliances. The majority of earlier

studies had issues with their design, particularly in terms of replicating by others and component availability.

III.Block Diagram:

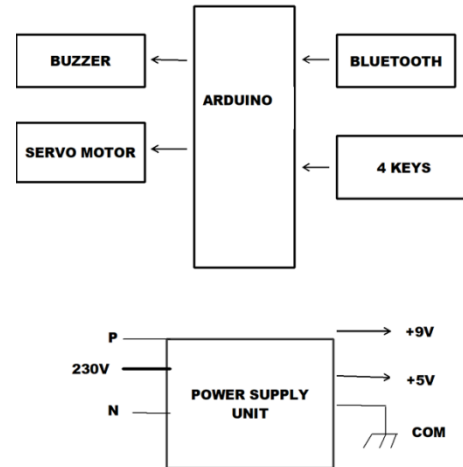

Fig: 1. Block Diagram

3.1 FLOW CHART:

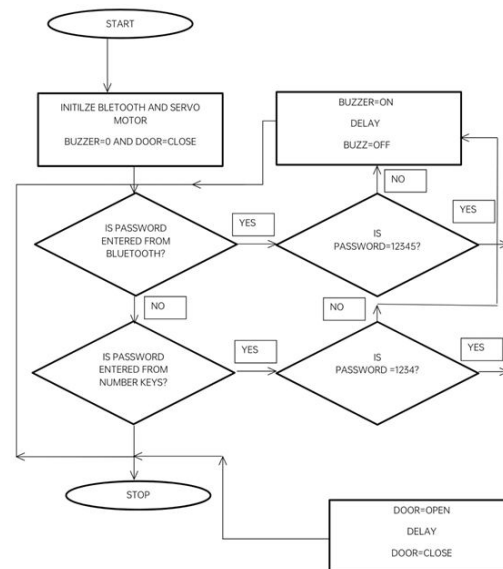

Fig:2.Block Diagram

IV.HARDWARE COMPONENTS

4.1 ARDUINO UNO:

The Arduino Uno is an open-source microcontroller board based on the Microchip ATmega328P microcontroller and developed by Arduino.cc and initially released in 2010. The board is equipped with sets of digital and analog

input/output (I/O) pins that may be interfaced to various expansion boards (shields) and other circuits. The board has 14 digital I/O pins (six capable of PWM output), 6 analog I/O pins, and is programmable with the Arduino IDE (Integrated Development Environment), via a type B USB cable. It can be powered by the USB cable or by an external 9-volt battery, though it accepts voltages between 7 and 20 volts. It is similar to the Arduino Nano and Leonardo. The hardware reference design is distributed under a Creative Commons Attribution Share-Alike 2.5 license and is available on the Arduino website. Layout and production files for some versions of the hardware are also available.



Fig:3.Arduino

4.2 BUZZER

A buzzer or beeper is an audio signaling device, which may be mechanical, electromechanical, or piezoelectric. Typical uses of buzzers and beepers include alarms, timers and confirmation of user input such as a mouse click or keystroke. A piezoelectric element may be driven by an oscillating electronic circuit or other audio signal source, driven with a piezoelectric audio amplifier. Sounds commonly used to indicate that a button has been pressed are a click, a ring or a beep.

Nowadays, it is more popular to use a ceramic-based piezoelectric sounder like a Sonalert which makes a high-pitched tone. Usually these were hooked up to "driver" circuits which varied the pitch of the sound or pulsed the sound on and off.



Fig:4.Buzzer

4.3. BLUETOOTH MODULE:

Bluetooth is a wireless protocol utilizing short-range communications technology facilitating data transmission over short distances from fixed and/or mobile devices, creating wireless personal area networks (PANs). The intent behind the development of Bluetooth was the creation of a single digital wireless protocol, capable of connecting multiple devices and overcoming issues arising from synchronization of these devices.

Bluetooth enables these devices to communicate with each other when they are in range. The devices use a radio communications system, so they do not have to be in line of sight of each other, and can even be in other rooms, as long as the received transmission is powerful enough. Bluetooth device class indicates the type of device and the supported services of which the information is transmitted during the discovery process.

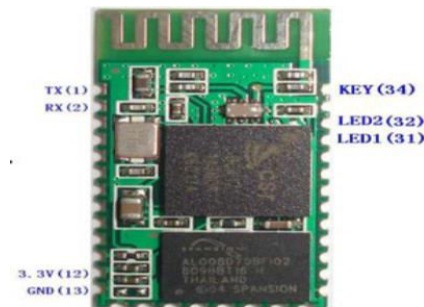

Fig: 5.HC- 05

4.4. PUSH BUTTONS

Push Buttons are normally-open tactile switches. Push buttons allow us to power the circuit or make any particular connection only when we press the button. Simply, it makes the circuit connected when pressed and breaks when

released. Some of the applications of the Push button are Calculators Push-button telephones, Kitchen appliances, Magnetic locks etc.

4.5. SERVO MOTOR

A servo motor is an electrical device which can push or rotate an object with great precision. If you want to rotate and object at some specific angles or distance, then you use servo motor. It is just made up of simple motor which run through servo mechanism. If motor is used is DC powered then it is called DC servo motor, and if it is AC powered motor then it is called AC servo motor. We can get a very high torque servo motor in a small and light weight package. Due to these features, they are being used in many applications like toy car, RC helicopters and planes, Robotics, Machine etc.



Fig:6.servo motor

Servo motors are rated in kg/cm (kilogram per centimeter) most hobby servo motors are rated at 3kg/cm or 6kg/cm or 12kg/cm. This kg/cm tells you how much weight your servo motor can lift at a particular distance. For example: A 6kg/cm Servo motor should be able to lift 6kg if the load is suspended 1cm away from the motors shaft, the greater the distance the lesser the weight carrying capacity.

The position of a servo motor is decided by electrical pulse and its circuitry is placed beside the motor.

4.6 POWER SUPPLY CIRCUIT

As in below figure this circuit is an approach to obtain both 12V and 5V DC power supply. The circuit uses two ICs 7812(IC1) and 7805 (IC2) for obtaining the required voltages. The AC mains voltage will be stepped down by the transformer T1, rectified by filtered by capacitor C1 to obtain a steady DC level. The IC1 regulates this voltage to bridge B1 and obtain a

steady 12V DC. The output of the IC1 will be regulated by the IC2 to obtain a steady 5V DC at its output. In this way both 12V and 5V DC are obtained. Such a circuit is very useful in cases when we need two DC voltages for the operation of a circuit.

The ac voltage, typically 220V, is connected to a transformer, which steps down that ac voltage down to the level of the desired dc output. A diode rectifier then provides a full-wave rectified voltage that is initially filtered by a simple capacitor filter to produce a dc voltage. This resulting dc voltage usually has some ripple or ac voltage variation.

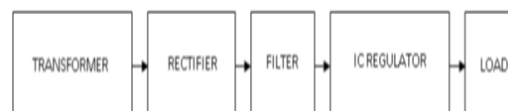

Fig:7.Block Diagram of Power Supply

V.RESULT:

This project is well prepared and acting accordingly (including all the hardware and software) as per the initial specifications and requirements of our project. Because of the creative nature and design the idea of applying this project is very new, the opportunities for this project are immense. The practical representation of an experimental board is shown below.

5.1 CIRCUIT DIAGRAM:

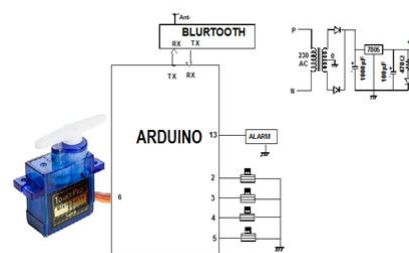

Fig:8. circuit Diagram

5.2.Photos of kit:

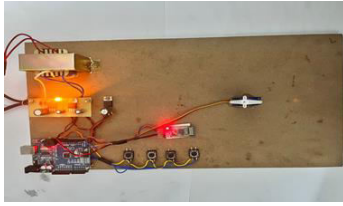

Fig:9.View of kit when power supply in ON

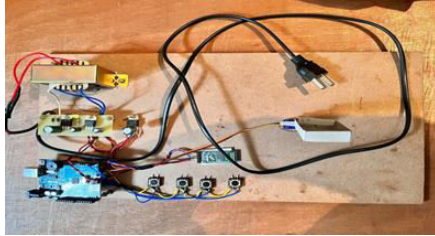

Fig:10View of kit when power supply in OFF

5.3 ADVANTAGES:

- Simple programmable code lock circuit.
- User can set his password for ensured protection instantly.
- Power required to operate this circuit is very less.
- it can be opened with smartphone, senior citizen or disabled don't have to struggle with keys or go near the door to open it.
- This prevents one from being locked inside or outside.
- With digital locks, there is no need for having spare keys since the locks are keyless. The only thing you need to do is giving the access code to people who you are close to.
- Digital locks can easily be reset by changing the access codes; this helps to increase security.
- Since these digital locks don't require keys to lock or unlock them, there is thus no loss of keys or even forgetting the keys somewhere.
- it is easier to keep small children inside using electronic door locks that are often childproof.

5.4 DISADVANTAGES:

- It is more expensive.
- you may need a pro to install the lock and sync it to your Bluetooth and Wi-Fi.
- Smart locks can also be pricey to fix if they malfunction

- the buttons eventually wear out on repeated usage, You should change your access code regularly to prevent significant wear and tear.
- digital lock is smart, but still glitches can happen. There are electronic issues that a traditional locksmith might not be able to fix.
- if your access code has fallen into the wrong hands. Someone could be looking over your shoulder when you enter your code at the door.
- A faulty system may result in a jamming of the security system although this is not a common occurrence.

5.5 APPLICATIONS:

- The electronic locks are especially widely used in access control systems
- Digital Door Locks for hotels are much demanded today. They allow you to keep a separate record of the movements of staff: maids, technicians and other employees. At the same time, guests can enjoy the increased comfort that modern technologies provide
- In entertainment and sports facilities, a key card or electronic bracelet serves as an entrance ticket, as well as a key to a personal locker, and an electronic means of payment.

VI.CONCLUSION SUMMARY AND REFERENCE

6.1 Summary

Recently proposed door lock systems based on Biometrics Techniques, Password Based and RFID have been studied and developed. This research project is centered on door locking system via smartphone controlled locking system with the help of Arduino and Bluetooth module. As well as unlocking door with keys present in the kit

6.2 Conclusion

The main aim of this paper is to design a smart door security system using Arduino and Bluetooth application and also physical keys are present in order if mobile is not present with the users, so that people can feel safe about their home whether they are away from home or are in the house. This project is based on Arduino,

Research Paper © 2012 IJFANS. All Rights Reserved, UGC CARE Listed (Group -I) Journal Volume 10, Issu 10, 2021

and the coding is done on Arduino idle platform using the Arduino application. At the end of this research the aim and objectives of the project were achieved. People can now feel more secure about their doors all the time. Doors can be controlled conveniently to those with access. Physically challenged people can open or lock doors from their Bluetooth paired smartphone device without asking help of anybody. It is safe to say that the main objectives and the aim of the project were achieved at the end of the project.

6.3 FUTURE SCOPE:

During this research some of the problems I came across were the inability of the door to close automatically after been open for a while unless locked from the application. For future research purpose I recommend other researchers to make a room to make the doors lock automatically after passing from the thr door with ir sensors instead of time delay. The door can only be accessed at a particular distance for future research the distance can be put into consideration and made to be longer.

REFERENCES:

While designing and fabrication of this project work, we studied lot of material gathered from websites, the theory related to the Arduino based technology; totally we have depended on websites only, because suitable books related to the subject are not available in the market. The information gathered from google.com search Engine, more ever during preparation of software plenty of books are referred regarding microcontrollers, the following are the references made during design, development and fabrication of the project work.

Text Books:

- (1) Linear Integrated Circuits by: D. Roy Choudhury, Shail Jain
- (2) Power Electronics by: SEN
- (3) Relays and their applications by: M.C. SHARMA
- (4) Practical transistor circuit design and analysis by: GERALD E. WILLIAMS

- (5) The 8051 Microcontroller and Embedded Systems by: MD Ali Mazidi
- (6) The concepts and Features of Micro-controllers by: Raj Kamal
- (7) The 8051 Micro-controller Architecture, programming & Applications by: Kenneth J. Ayala
- (8) <https://www.arduino.cc/en/main/howto>

Catalogs:

- (1) TEXAS - LINEAR IC's manual
- (2) SIGNETICS - DIGITAL IC's manual

Journals:

- (1) Electronic Design
- (2) Electronics for you
- (3) Electronics Text