

A Model Predictive Control of 1- Φ Grid Connected Reduced Switch 7-Level Inverter

Silveru Sarada
Asst. Prof. Dept. of EEE,
AITS, Rajampet,
Andhra Pradesh, India
saradasasi@gmail.com

Ganesh Challa
Asst. Prof. Dept. of EEE,
AITS, Rajampet,
Andhra Pradesh, India
ganesh.challa@gmail.com

Dr.N.Ravisankara Reddy
IEEE member, Asso. Prof. in EEE,
G.Pulla Reddy Engg. College
Kurnool, Andhra Pradesh, India
netapallyravi@gmail.com

Abstract — Multi Level Inverter's (MLI's) has been considered as the primary choice for most of the industrial applications because of its reliability and high-power handling capability. In this paper, model predictive control has employed to guess the future values of load current by referring all the possible voltage vectors delivered by the inverter. Discrete-time model of the system is utilized to achieve the above-mentioned function. The voltage vector by which the quality function is minimized, is selected. Then the usage of switch state deduced that obtained by the selected voltage vector is used to control the next output voltage of the inverter. This model is easy to implement and it has the ability to overcome the drawbacks of conventional control techniques that are applied to the MLI's. The result conveys that the model predictive control can effectively controls the load current and this system functions well.

Keywords— multilevel inverter, model predictive control, tracking performance.

I. INTRODUCTION

Because of the vast usage of the fossil fuels, there is a sharp decrement in the availability of fossil fuel resources. To meet the day-to-day requirements of electricity, it's time to shift to the renewable energy sources. With the advancements in solar energy, the control techniques of grid connected inverters has been deploying from the few years. In order to obtain the above mentioned features, a multilevel inverter with minimum number of switches can be implemented to get a smooth sine wave. MLI's is widely used in high power applications such as large induction drive, UPS systems and FACTS systems.

Required output will be obtained from several level of dc links that are used in the circuit. Most commonly there are three different types of Multi Level Inverter (MLI) topologies [1]-[2] used and they are Diode-clamped MLI's, Flying capacitor MLI's and Cascaded H-Bridge MLI's. Basically, three control techniques are available for controlling the grid connected multilevel inverters and those are Carrier wave comparison technique, Hysteresis loop control technique and predictive control technique. The widely used technique is the carrier wave comparison control, which tracks the output current by using a PI

Controller [3]. But it fails in reducing the steady-state error between the target current and the original current. The simplest control technique is the hysteresis loop control

technique and it has the advantage of having good robustness [4]-[6], but it has high ripple content in the output current, which may increase the losses and thereby reducing the efficiency of the system. The another major drawback is the unstable switching frequency. Model Predictive Control (MPC) is the main branch of Predictive control techniques. A model has to be established for the system in MPC [7]-[12]. Depending upon the designed model, the upcoming values of the variables can be predicted. Based on the comparison of the predicted values and the required reference values, the control action at this present moment will be taken. MPC structure is very simple for designing and modelling. Predictive control mode can be implemented on a digital signal processor and its output has small distortions in the current and harmonics are minimized.

II. DIODE CLAMPED MULTILEVEL INVERTERS

The most common multilevel architecture was introduced in 1975 and uses diode-clamped inverters. A diode serves as the clamping device in DC-MLI, which steps the output voltage by clamping the dc bus voltage. The primary concept behind the inverter is to employ diodes to minimize the voltage stress on the power electronic elements. A Vdc voltage is applied to each capacitor and switch. The number of shifting elements required are $2^{*(m-1)}$, diodes are $(m-2) * (m-1)$, and voltage sources are necessary for a m level inverter $(m-1)$. As the number of output voltage levels increase, the voltage waveform grows closer to a sinusoidal waveform and the output voltage quality improves.

III. REDUCED SWITCH 7-LEVEL INVERTER

A DC-MLI is a popular type of multilevel structure that uses diodes to clamp a component to the voltage of a dc bus to produce voltage steps in the output voltage waveform. The output voltage level determines the number of components required in all types of multilevel inverter. Fig.1 proposed new single-phase topology

When more power switches are added to the inverter circuit, the price, control complexity, size, and the area for set up also increase. To provides wide range of output levels

while minimizing the number of switches, the envisaged multilevel inverter employs an innovative power generating schematic diagram and an appropriate method to detect the level of the dc voltage source. The new configuration is as shown in Fig.1.

The variety of different output voltage levels can be calculated by using the following equation, as in the shown MLI:

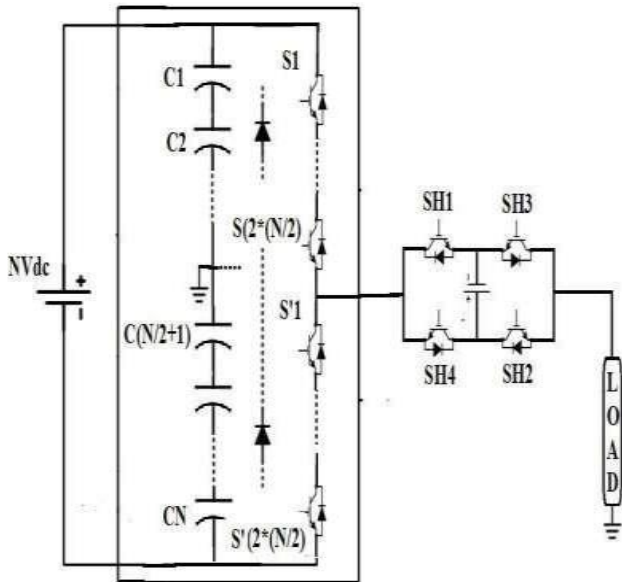

Fig.1 Diode Clamped Multilevel Inverter (DC-MLI)

$$\text{No. of Levels} = 2N + 3 \quad (1)$$

Where N is the number of voltage levels.

The following equation represents the single-phase maximum output voltage (V_{Omax}).

$$V_{Omax} = (N+1) * Vdc / 2 \quad (2)$$

In this new configuration, the below equations give the number of switches and diodes required,

$$\text{No. of Switches} = 2N+4 \quad (3)$$

$$\text{No. of Clamping diodes} = N(N-1) \quad (4)$$

IV. REDUCED SWITCH 7-LEVEL INVERTER TOPOLOGY

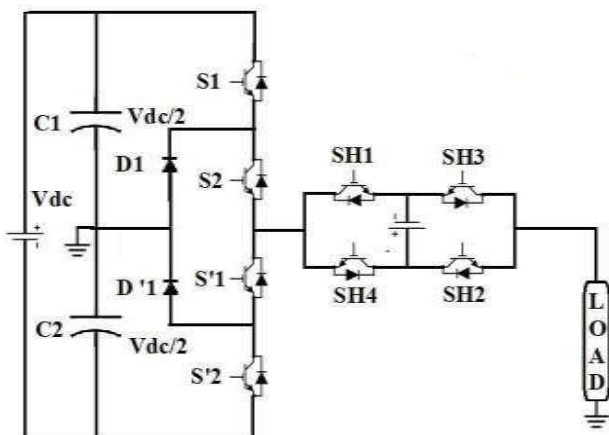

Fig.2 Reduced Switch 7-Level Inverter

A model focused on the proposed architecture is simulated in order to confirm that the offered multilevel inverter produces an appropriate waveform of output voltage. Software called MATLAB Simulink power block set was used for the simulation. A seven-level staircase waveform with a frequency of 50 Hz is produced using the proposed multilevel in Fig.2. The following settings were used to test the filter in use: C = 10µF, L = 0.5mH, and a load of 25Ω.

TABLE I. SWITCHING STATES OF THE INVERTER

Switches	1.5 Vdc	1 Vdc	0.5 Vdc	0	-0.5 Vdc	-1 Vdc	-1.5 Vdc
S1	ON	ON	OFF	OFF	OFF	OFF	OFF
S2	ON	ON	ON	ON	ON	OFF	ON
S'1	OFF	OFF	ON	ON	ON	ON	ON
S'2	OFF	OFF	OFF	OFF	OFF	ON	OFF
SH1	ON	ON	ON	ON	OFF	OFF	OFF
SH2	ON	OFF	ON	OFF	OFF	ON	OFF
SH3	OFF	ON	OFF	ON	ON	OFF	ON
SH4	OFF	OFF	OFF	OFF	ON	ON	ON

The switching states of the inverter to get 7-Levels in the output voltage is depicted in the table.I

V. MODEL PREDICTIVE CONTROL SCHEME

Model Predictive Control is the main branch of Predictive control techniques. A model has to be established for the system in MPC [7]-[12]. Depending upon the designed model, the upcoming values of the variables can be predicted. Based on the comparison of the predicted values and the required reference values, the control action at this present moment will be taken. MPC structure is very simple for designing and modelling. Adaptive control mode can be implemented on a digital signal processor, and its output has small deviations in current, reducing harmonics. It uses the toggle states deduced from the selected voltage vectors to control the next output values.

This control technique can be described as follows:

1. A model for the inverter output voltage vector has to be built.
2. A model for the load current has to design.
3. Quality function G has to be defined.

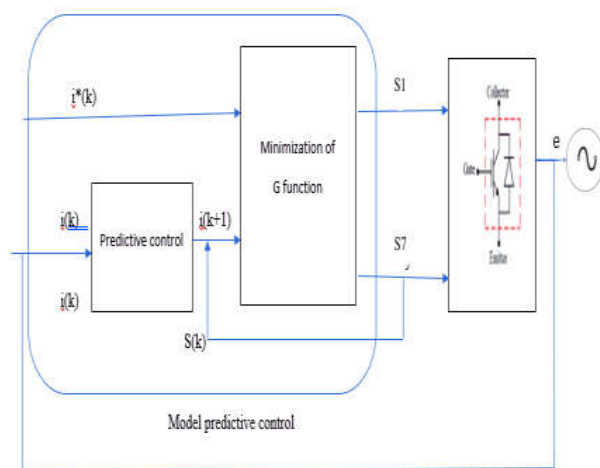

Fig.3 Schematic Representation of Model Predictive Control.

The model predictive control block diagram is shown in Fig.3. The following steps has to be followed for obtaining the model predictive control:

1. The measured value of load current is $i(k)$, and the reference value of load current is $i^*(k)$.
2. Model predictive control of load current is employed to calculate all possible output current values for future values.
3. A correlation must be carried out to identify the switching states with the smallest quality function values.

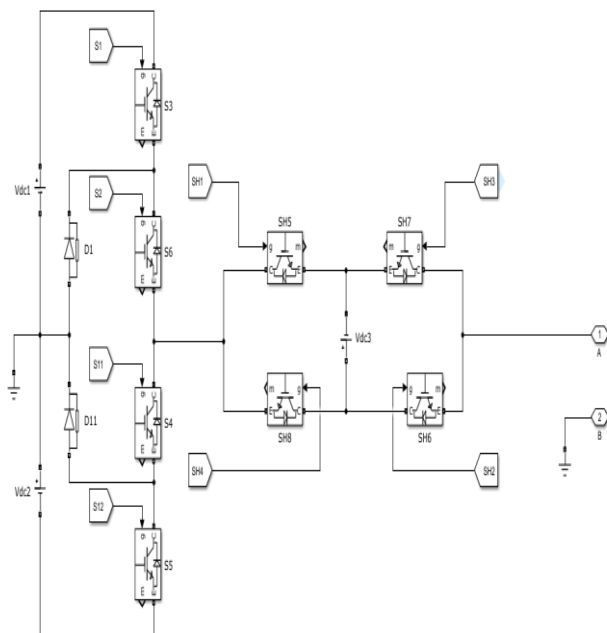

Fig.4 Simulink model for Reduced Switch 7-Level Inverter

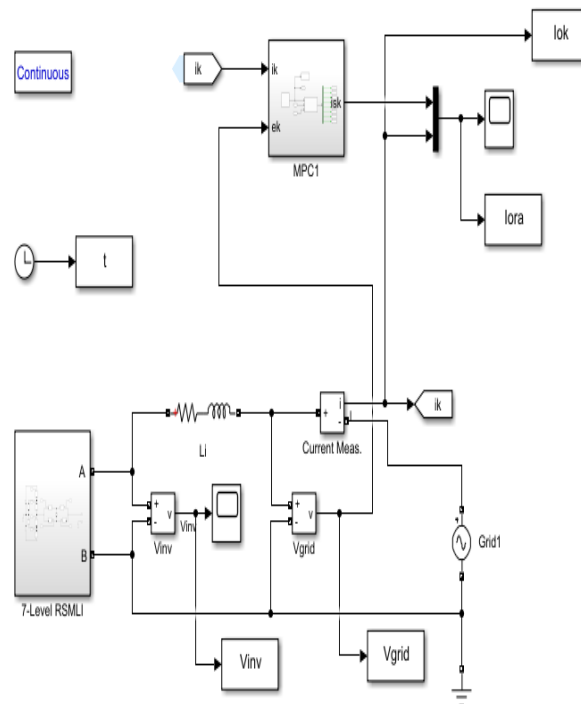

Fig.5 Simulink model for Model Predictive Control of Grid Connected Reduced Switch 7-Level Inverter

Fig. 4 shows the Simulink model for reduced switch 7-level inverter, Fig.5 shows the Simulink model for Model Predictive Control of Grid Connected Reduced Switch 7-Level Inverter. In this paper, the inverter is operated with Sinusoidal Pulse Width Modulation (SPWM) and MPC based schemes. The feasibility of MPC scheme is compared with SPWM scheme in the MATLAB/Simulink environment.

VI. RESULTS AND DISCUSSION

A. Sinusoidal Pulse Width Modulation

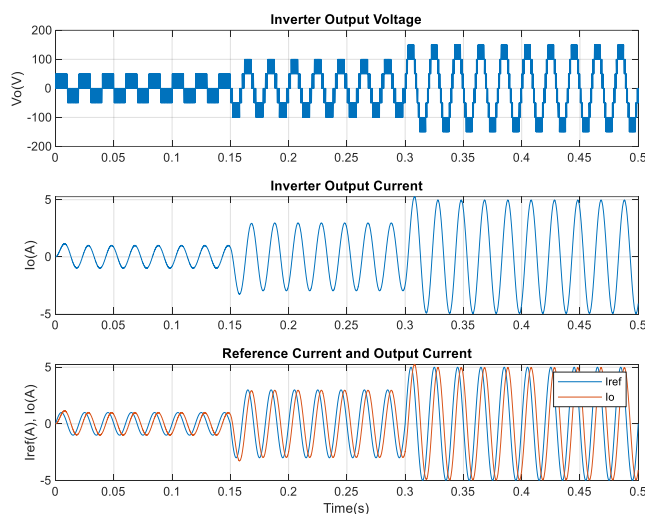
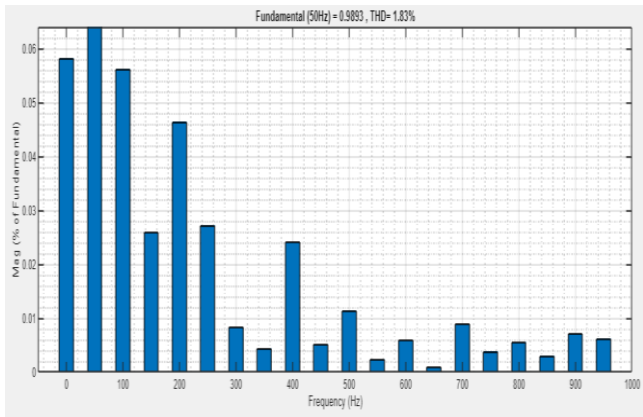
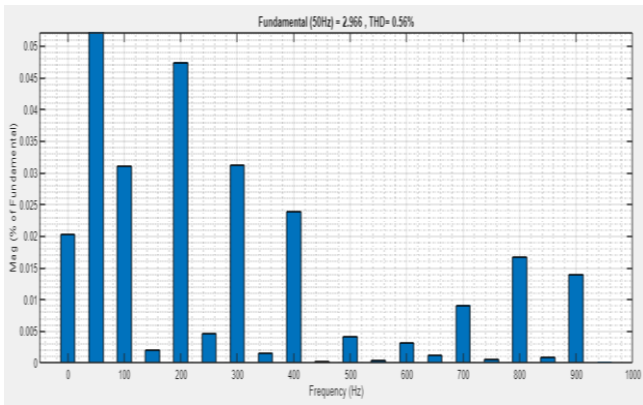

Fig.6 Simulation results for inverter output voltage, inverter output current reference current and output current.



(a)



(b)

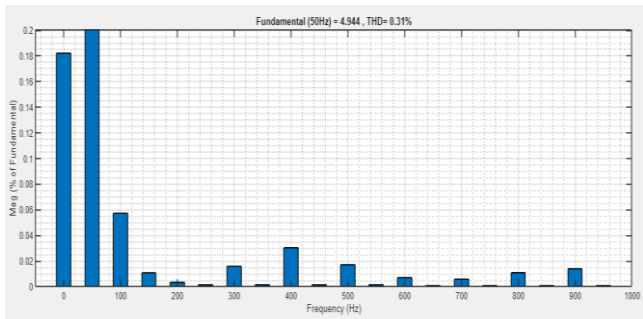

(c)

Fig.7 Harmonic Spectrum of output current for reference current a) 1A b) 3A and c) 5A

B. Model Predictive Control

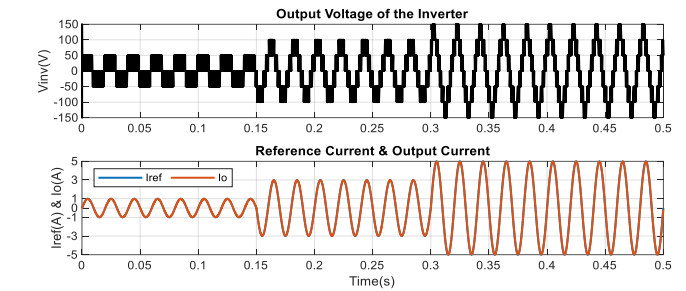
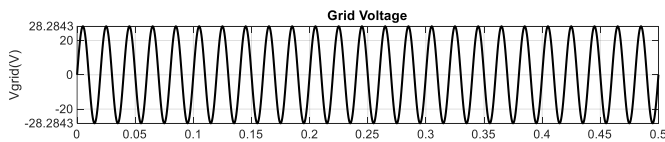
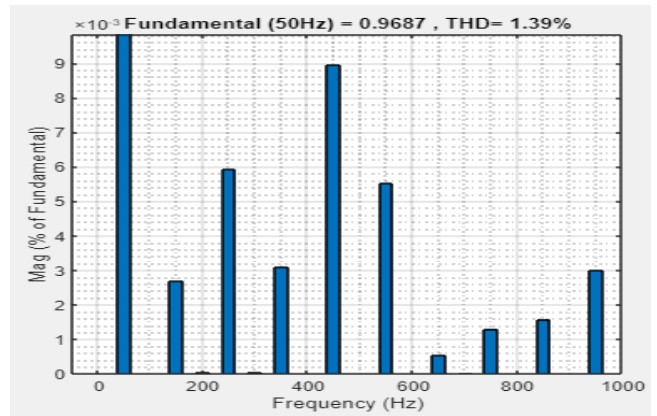
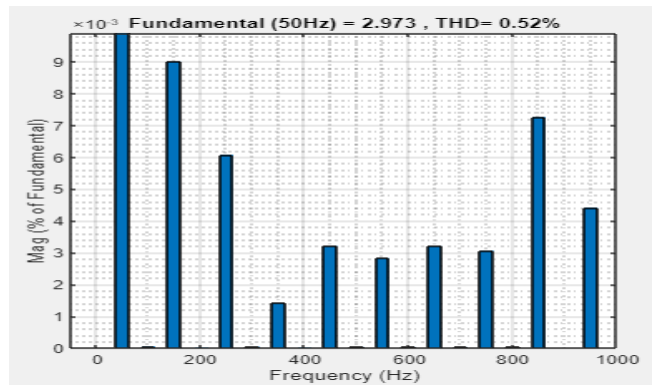

Fig.8 Simulation results for grid voltages, inverter output voltage, reference current and output current.



(a)



(b)

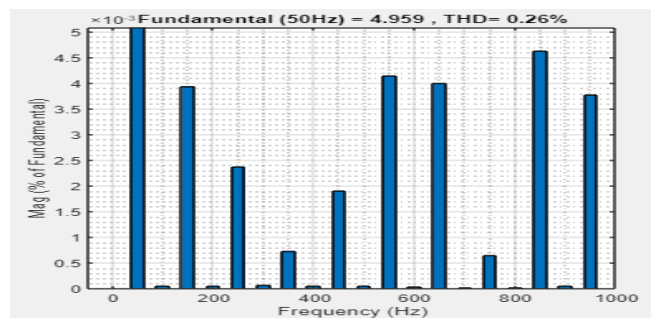

(c)

Fig.9 Harmonic Spectrum of output current for reference current a) 1A b) 3A and c) 5A

Fig.6 and fig.8 shows the waveforms of output voltage, reference current and output current of the inverter for SPWM and MPC schemes respectively. From $t=0s$ to $t=0.15s$, the inverter produces 3-level output voltage, from 18075

$t=0.15s$ to $t=0.3s$, 5-level output voltage and from $t=0.3s$ to $t=0.5s$, 7-level output voltage based on reference current demand i.e. as the reference current increases, the inverter generates higher levels in output voltage.

In fig.6, the output current is not tracking with reference current in case of SPWM technique whereas in fig.8 the output current is exactly tracking with reference current in case of MPC scheme. This confirms the effectiveness of MPC over SPWM technique.

TABLE II. COMPARISON OF TOTAL HARMONIC DISTORTION

S. No.	Reference Current	THD in SPWM Technique	THD in MPC Scheme
1.	1A	1.83	1.39
2.	3A	0.56	0.52
3.	5A	0.31	0.26

From table II, the harmonic content will get reduced with increase in reference current magnitude. Also, it is seen that, MPC scheme offers less THD as compared to SPWM technique.

VII. CONCLUSION

This work proposes a novel MPC based 1- Φ grid connected MLI scheme that require fewer switches. The MLI's action is clearly outlined. The MPC scheme and SPWM techniques thoroughly compared. The topology was simulated using MATLAB/Simulink. The simulation results are also shown to demonstrate how effective the proposed model is. The FFT analysis is advantageous because it has a lower THD. The proposed control scheme would be very reliable and the effectiveness is increased, also reduced switch MLI topology have offers the minimal switching and conduction losses due to its modest component count.

REFERENCES

- [1] V. Singh and R. S. Singh, "A comparative study of multilevel inverter topologies," *Int. Res. J. Eng. Technol.*, vol. 5, no. 3, pp. 1009–1014, Mar. 2018.
- [2] Salem, H. Van Khang, K. G. Robbersmyr, M. Norambuena and J. Rodriguez, "Voltage Source Multilevel Inverters With Reduced Device Count: Topological Review and Novel Comparative Factors", in *IEEE Transactions on Power Electronics*, vol. 36, no. 3, pp. 2720-2747, March 2021.
- [3] Dhananjayulu, D. Prasad, S. Padmanaban, P. K. Maroti, J. B. Holm-Nielsen, and F. Blaabjerg, "Design and implementation of seventeen level inverter with reduced components," *IEEE Access*, vol. 9, pp. 16746-16760, 2021.
- [4] A. Shukla, A. Ghosh and A. Joshi, "Hysteresis Modulation of Multilevel Inverters," in *IEEE Transactions on Power Electronics*, vol. 26, no. 5, pp. 1396-1409, May 2011, doi: 10.1109/TPEL.2010.2082001.
- [5] Rohith Balaji Jonnala, Ch Sai Babu, A Modified Multiband Hysteresis Controlled DTC of Induction Machine with 27-level asymmetrical CHB-MLI with NVC modulation, *Ain Shams Engineering Journal*, Volume 9, Issue 1, 2018, ISSN 2090-4479.
- [6] R.Latha, C.Bharatirajaa, R.Palanisamyb, Sudeep Banerjee, Dr.Subhransu Sekhar Dash, "Hysteresis Current Controller based Transformerless Split Inductor-NPC-MLI for Grid Connected PV-System" *International Conference on Design And Manufacturing 2013 (ICoNDM 2013)*.

- [7] Yang Zhao, Caiyong Ye, Yongzihao Dai, Kaifeng Liu, Sifeng Zhao, Cong Deng, "Research on Predictive Current Suspension Control of Permanent Magnet Bearingless Motor", *2021 IEEE 4th Student Conference on Electric Machines and Systems (SCEMS)*, pp.1-4, 2021.